

# STUDIES IN ALICYCLIC SYSTEMS

UNIVERSITY LIBRARY  
UNIVERSITY LIBRARY  
UNIVERSITY LIBRARY

Thesis Submitted for the Degree of  
Doctor of Philosophy (Science)  
of the  
University of North Bengal

By

(Mrs.) MANGO MURTHI (BHAUMIK), M. Sc  
DEPARTMENT OF CHEMISTRY  
University of North Bengal

1986

(REVISED 1987)



INDEX

ACKNOWLEDGEMENTS	...	...	
Synopsis	...	...	(i) to (iii)
Part I	...	...	1 to 124
Part II	...	...	125 to 147
Part III	...	...	148 to 168
Appendix	...	...	169 to 175

## ACKNOWLEDGEMENTS

I wish to acknowledge my deep sense of gratitude to:

the University Grants Commission, New Delhi for the award of a Fellowship under the Faculty Improvement Programme and to the Principal, Siliguri College for grant of Study Leave; the Regional Sophisticated Instrumentation Centre, Lucknow (India) and Dr Mitsuo Miyazawa of Kinki University Japan for the PMR and Mass Spectra;

Drs A. Majumdar and S. Saha for recording the UV and IR spectra; Miss Purabi Sarkar, UGC Research Fellow for her help in the laboratory;

Prof Pelayo Camps of the University of Valencia, Spain for going through the thesis and suggesting modifications;

my daughters (late) Sraboni and Suvarna who bore admirably with me during the tenure of my fellowship and my husband Dr G.S.S. Murthi for suggesting the problem and providing necessary laboratory facilities.

The work is dedicated to the memory of my beloved daughter Sraboni who left us to her heavenly abode.

*Mango Murthi*  
(Mrs) Mango Murthi

## S Y N O P S I S

The thesis entitled "Studies in Alicyclic Systems" embodies the results of the investigations carried out by the author during the period March 31, 1981 through March 30, 1985 in the Organic Chemical Laboratories of the University of North Bengal. The thesis is divided into three parts; in the first part are described some experiments on the action of bases on some bicyclic epoxyketotosylates; in the second part are described the preparation and some reactions of 1,2-bis(2'-oxocyclohexyl)ethane and in the third part the preparation of some polyesters based on p-hydroxybenzoic acid with terminal mesogenic units and a central spacer.

Bicyclic  $\gamma$ -hydroxytosylates are known to undergo fragmentation to give large rings. The study of these

(ii)

reactions is well documented.  $\alpha$ ,  $\beta$ -epoxyketones have been reported to undergo Favorskii rearrangement. It was felt that a system incorporating both the structural features would present some interesting possibilities. In order to study these possibilities, we synthesized the compounds (i) to (iii) and studied the action of bases on these systems. The results are discussed in the main body of the thesis.

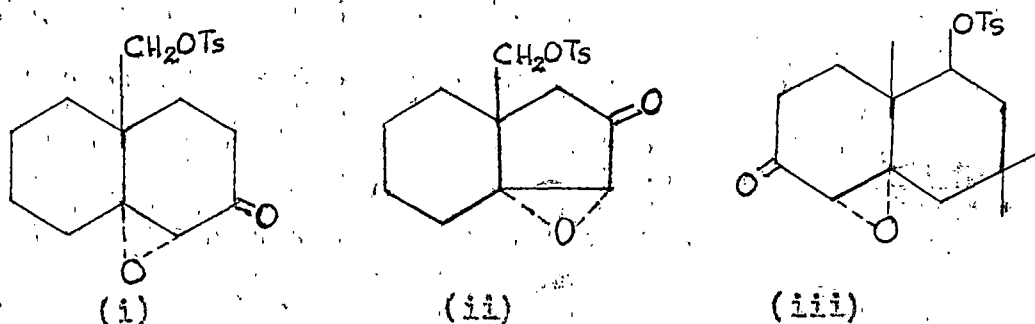

In an attempt to prepare the spiro-octanone (iv) by condensing cyclohexanone with dibromooctane, the hitherto unknown 1,2-bis(2'-oxocyclohexyl)ethane (v) was obtained. Some reactions of the compound have been described in detail in Part II of the thesis.

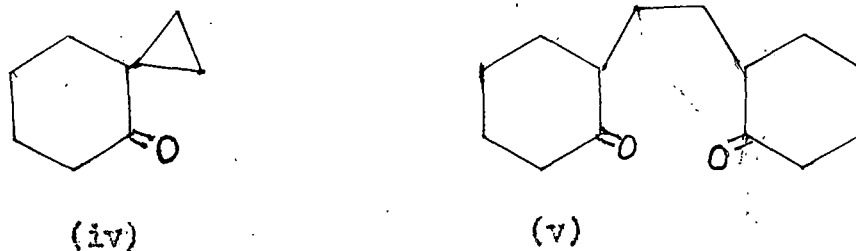

In the third part are described the preparation of some

(iii)

compounds which may exhibit thermotropism. Preparation of this type of compounds is mostly described in patent literature. The methods described are alternative methods.

During the revision of the thesis some structures originally proposed by us have been revised in the light of some observations made by Prof. Pelayo Camps of the University of Valencia, Spain. The author wishes to acknowledge her deep sense of appreciation and thanks to Prof. Camps.

STUDIES IN ALICYCLIC SYSTEMS PART I

Action of bases on some epoxyketosylates

## INTRODUCTION

The classical unity of the terpene group of compounds as shown by their simple composition (limited to three organogenic elements, carbon, hydrogen and oxygen) together with their structural diversity and ubiquity of occurrence has made terpenes one of the most explored group of compounds. In spite of the long history of these compounds, the field is far from exhausted and remains a rich source of new findings and fresh inspiration.

Of the large number of terpenoid natural products known today, the sesquiterpenes represent the largest single class consisting of diverse structural types, the perverse nature of whose ring systems has been taxing the talents and investigative skills of organic chemists since the very beginning of modern organic chemistry.

The discovery in nature of polyethenoid mono- and bicarbocyclic sesquiterpenes derived from cyclononane to cycloundecane (Chart I) came as a great surprise since earlier large carbocyclic compounds found in nature were

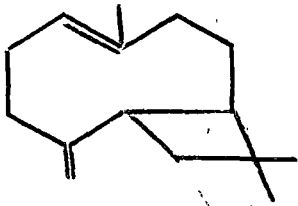

Caryophyllene

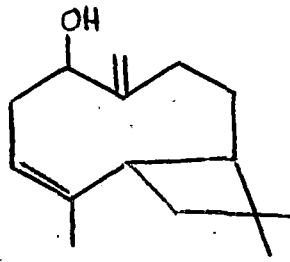

$\alpha$ -Butulenol

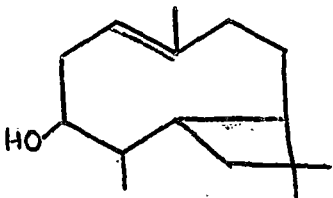

$\beta$  - Butulenol

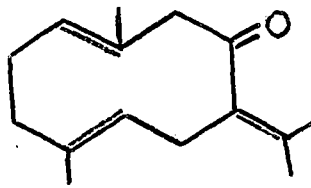

Germaerone

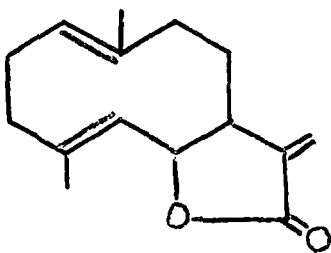

Costunolide

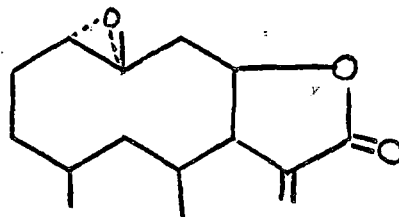

Pyrethrosin

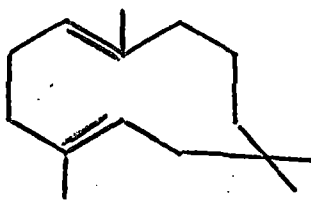

$\beta$  - Humulene

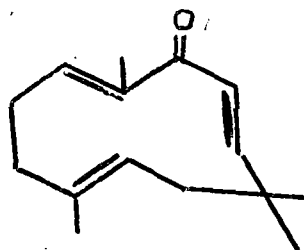

Zerumbone

Chart I

macrocyclic fragrant ketones like Civetone (1) and Muscone (2).

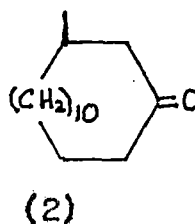
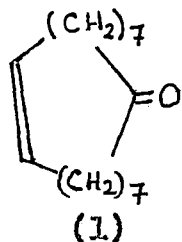

These ring systems (cyclononane to cycloundecane) were extremely difficult to synthesize and it was earlier thought that compounds of this type were products of human thought and endeavour. The structural elucidation of these compounds by classical chemical and modern instrumental methods is definitely an achievement on the part of an organic chemist. The synthesis of these systems by classical methods poses certain difficulties and new methods were devised and are being devised continuously reflecting the great interest in these systems.

It is appropriate at this juncture to review the thermodynamics of ring formation reactions in general to appreciate the reasons of the difficult accessibility of these ring systems.

Ease of ring formation may be discussed under two

heads: (i) as a function of ring size and (ii) as a function of the nature and degree of substitution of the ring atoms.

Ease of ring formation is not synonymous with ring stability; however, activation energy for ring closure might reflect the stability of the ring formed to some extent, though other factors enter. The most important of these involves the probability of having the ends of the ring forming chain approach each other. This probability decreases as the ring size increases and reflects itself in an unfavourable activation entropy for the formation of medium and large rings. The overall ease of ring closure thus may be derived from two factors; a monotonous decrease in the ease of having the ends of the ring meet and a strain factor which becomes more favourable to closure as the ring size increases from three to six-membered, then less favourable again as it increases further upto nine-membered, then more favourable for larger rings. In the overall result, ease of ring formation is relatively high for three-membered rings (because of the high probability factor, three atoms are necessarily in the optimum position for ring formation). It drops sharply for the four-membered rings (if four atoms are arranged in the most stable conformation, as in anti-butane, they cannot form a ring; the best conformation for the ring formation is the very unfavourable eclipsed conformation). For the five-membered rings

there is a sharp rise because of the considerable reduction in the strain factor. The ease of formation of a six-membered ring is less than for a five-membered one because the slight improvement in the strain factor is outweighed by a deterioration in the distance factor. There is a sharper drop for the seven-membered ring (both strain and distance factors become worse) and even a sharper drop for eight-membered ring (where non-classical strain sets in). After that, the distance factor has become about constant and the ease of forming larger rings reflects the strain factor; low ease of ring formation for 9 and 10 membered rings (because of non-classical strain) improving for 11 and 12 membered rings, and levelling off for still larger cycles.

The easier closure of three membered rings as compared with four membered ones is well illustrated by the ready formation of epoxides from 1,2-halohydrins in contrast to the ~~the~~ difficulty in preparing trimethylene oxides from 1,3-halohydrins. Yet the epoxides, once formed, are much more easily opened than the trimethylene oxides, reflecting the lesser stability of the three-membered ring. The energetic situation is summarized in Fig. 1. A similar situation exists with regard to the ease of formation and stability of five and six-membered rings. The five-membered

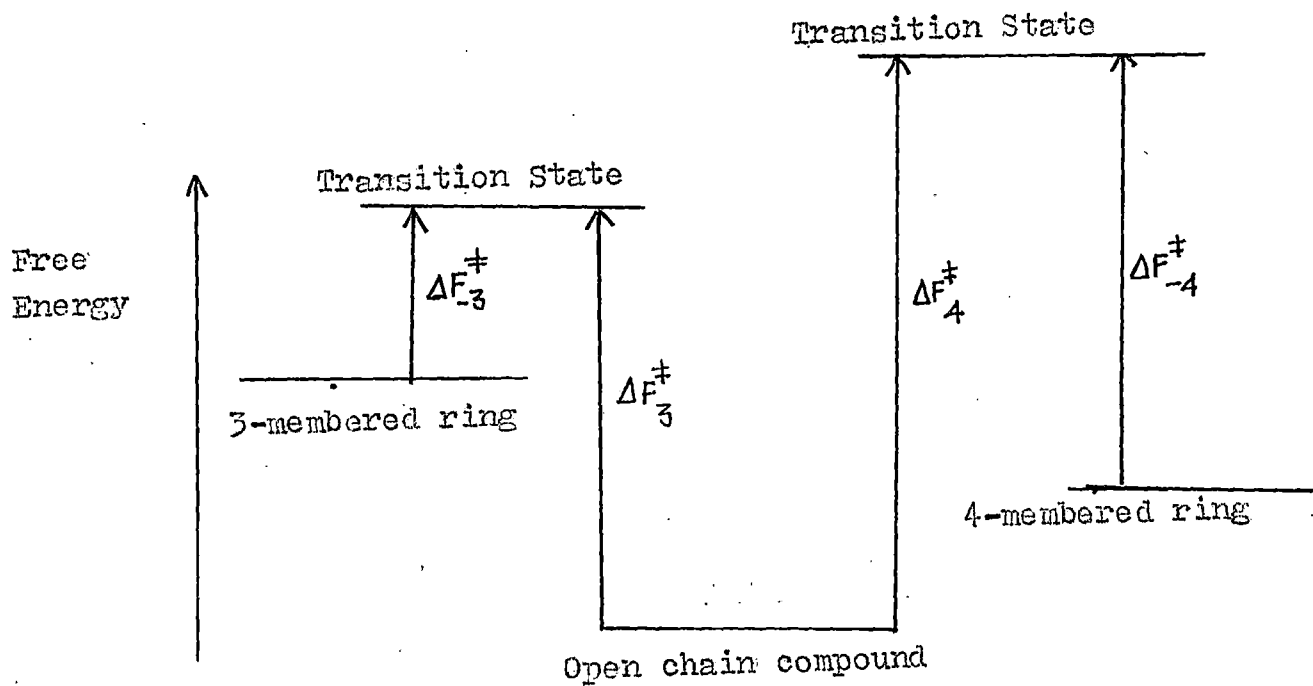

Ease of Ring Formation Vs Ring Stability

Fig - 1.

ring is easier to close but is less stable. A clear-cut illustration of this state of affairs is the reaction of glycerol with formaldehyde to give either a five-membered or a six-membered cyclic acetal. Formation of the five-membered ring compound, 4-hydroxymethyl-1,3-dioxolane (3) is faster, and this product will predominate if the reaction mixture is worked up after a short time. However, the formation of (3) is reversible, and if the reaction is allowed to continue for a long period, equilibrium of all the three sets of species will be established. If the reaction mixture is worked up at this point, the main product is the six-membered 5-hydroxy-1,3-dioxane (4), the thermodynamically more stable of the two cyclic acetals (3) and (4). Although six-membered acetals are usually more

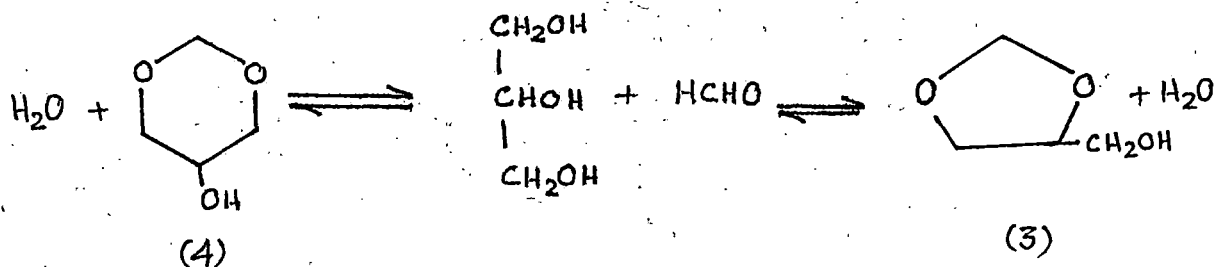

stable than the five membered ones, the opposite is usually true of ketals. The reason for this is shown in Fig.2.

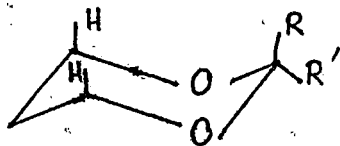

FIG.2.

When both R and R' are larger than hydrogen (as will be the

case in a ketal) an axial interaction will necessarily be generated in the six-membered ring, diminishing its stability below that of the corresponding five-membered ring. This is the reason why the acetone derivatives of sugars are 1,2-ketals rather than 1,3-ketals.

The dioxolane (3) is said to be the product of "Kinetic Control", which means that it is the product of the faster of the two reactions. In contrast, the dioxane (4) is said to be the product of "thermodynamic control", meaning the product predominating at equilibrium.

As explained above, the formation of rings larger than seven-membered is not easy, and the problem has long been a challenge to synthetic organic chemists, especially since some valuable naturally occurring perfumes, such as muscone, contain large rings. One of the early methods of synthesizing large rings is due to Ruzicka<sup>2</sup> and consists in the pyrolysis of the thorium salts of dibasic acids to give cyclic ketones. (FIG.3) The method serves to synthesize 8-membered rings as well as rings of 13 members and above (although the yields are low) but fails for rings of 9 to 12 members. Another method, due to Ziegler,<sup>3</sup> involves ring closure of a dinitrile with bases (Fig. 3). In order to obtain good yields in this method, it is necessary to operate in very dilute solutions as to avoid linear polymerization of the

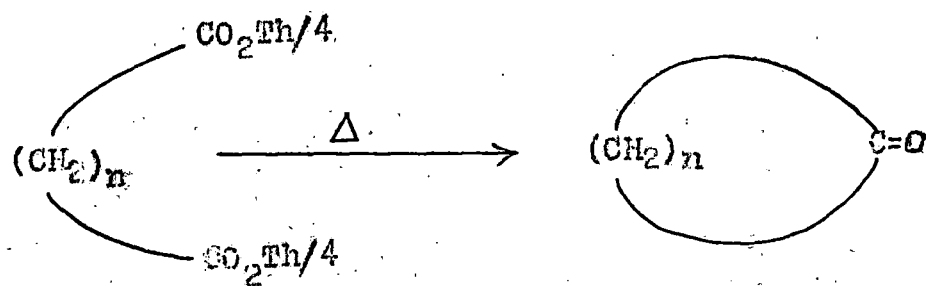

(RUZICKA)

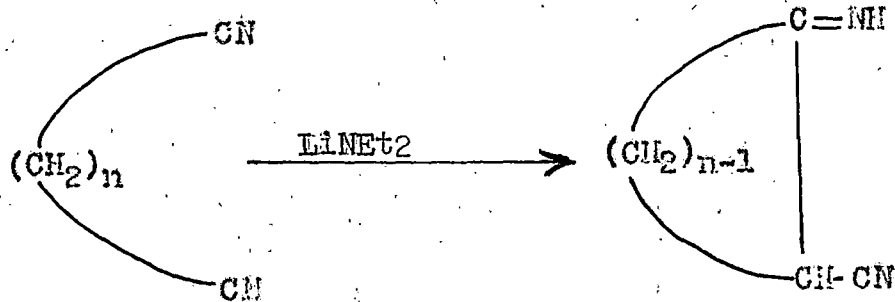

(ZIEGLER)

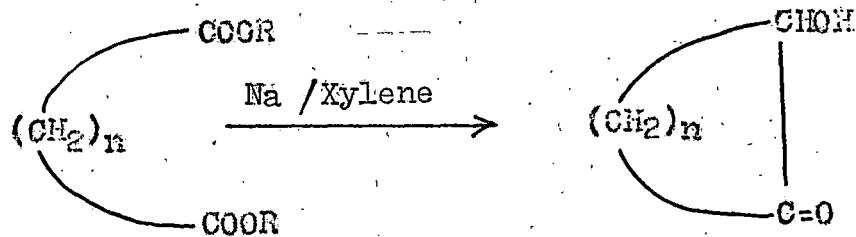

(HANSLEY, PRELOG, STOLL)

Methods for Synthesizing Medium & Large Rings

Fig - 3

difunctional nitriles. This so called "dilution principle" was first recognized and applied by Ruggli<sup>4</sup> and is based on the fact that the rate of an intramolecular ring closure generally depends on the first power of substrate concentration, whereas the rate of an intermolecular dimerization is proportional to the square of the concentration of the substrate. Therefore, decreasing substrate concentration decreases rate of dimerization much more than the rate of intramolecular ring closure. However, even with the use of dilute solutions, the Ziegler ring-closure fails for rings of 9, 10, and 11 members. In fact, the rings of this size were not accessible at all until the discovery of acyloin condensation.<sup>5</sup> Acyloin synthesis (reaction of a diester with sodium to give an  $\alpha$ -hydroxyketone) is particularly suitable for the synthesis of medium rings. (Fig 3) This synthesis gives high yields for large as well as medium rings and has been applied to four-<sup>6</sup> and five-membered rings.<sup>7</sup> It is not necessary to use high dilution. The amazing success of this method has been explained<sup>8</sup> as being due to adsorption of the functional groups of the diester on the surface of sodium, which automatically brings the two ends of the molecule in close proximity.

As a result of the application of the acyloin synthesis to medium and large rings, many functional derivatives of these rings are now readily available and have

been extensively studied.

It must be clearly pointed out that the stability of the ring systems is not related to the ease of ring formation, necessarily. Ring stability depends on (i) the size of the ring (ii) the nature of the ring and (iii) the nature of various substituents on the ring.

A number of interesting studies correlating stability of rings with size are available. The meaning of "stability" in this context is subject to a certain amount of confusion. For example, ease of ring closure has occasionally been used as an indicator of stability. However, ease of ring closure is a matter of kinetics and depends on the difference in free energy between the acyclic starting material and the transition state for ring closure; it is not necessarily related to the stability of the product. Thermodynamic stability of rings should be measured by the position of equilibrium in a reaction in which an open-chain and a cyclic compound are equilibrated (such as a hydroxyacid - lactone equilibrium) but very little information of this type is available. The most informative studies so far are thermochemical in nature; they are concerned with heats of combustion of cycloalkanes and the differences in enthalpy between them. Several such measurements are summarized

in Table-1 below. The heat of combustion per methylene

Table - 1.

Heats of combustion of cycloalkanes per methylene group<sup>a</sup>

n	Hc/n	(Hc/n)-157.4	n	Hc/n	(Hc/n)-157.4
3	166.6	9.2	11	158.4	1.0
4	163.95	6.55	12	157.7	0.3
5	158.7	1.3	13	157.8	0.4
6	157.4	0.0	14	157.4	0.0
7	158.5	0.9	15	157.5	0.1
8	158.6	1.2	16	157.5	0.1
9	158.8	1.4	17	157.2	-0.2
10	158.6	1.2	$\infty^b$	157.4	0.0

a. in kilocalories per mole of gaseous cycloalkane, divided by the number of methylene groups, n. Data from References 9 - 12

b. Value per methylene group in n-alkane group is high in cyclopropane, drops to a minimum in cyclohexane (which has about the same heat of combustion per methylene group as an open-chain compound), rises to a maximum in cyclononane and then drops again to reach the n-alkane value at about cyclotetradecane.

V. Prelog and H.C. Brown<sup>13</sup> have classified ring compounds into four categories, namely, "small rings"

(three and four membered), "common rings" (five, six and seven membered), "medium rings" ( eight to eleven membered) and "large rings" (12 membered and larger). [Originally 12-membered rings were classified with the medium rings. However Table I indicates that their heat of combustion per methylene group is closer to that of the larger rings than to those of the 8 to 11 membered rings. Other recent evidences also tend to group the 12-membered rings with the large rings.]

Table-I shows that small and medium rings tend to have anomalously high heats of combustion whereas large rings have "normal" heats of combustion similar to those of the appropriate acyclic analogues. Among the common rings, cyclohexane has a "normal" heat of combustion but that of cyclopentane and of cycloheptane is somewhat enhanced.

The high heat of combustion of small rings is appropriately accounted for by the Baeyer strain theory.<sup>14</sup> Baeyer pointed out that the bond angles in small rings ( $60^\circ$  in cyclopropane, Ca  $90^\circ$  in cyclobutane and Ca  $108^\circ$  in cyclopentane) deviate from the normal tetrahedral angle of  $109^\circ 28'$  and that therefore these rings are strained. [Because of non-coplanarity of the ring carbons, the angles in cyclobutane and cyclopentane may be slightly smaller.] The strain (often called angle strain or Baeyer strain) is

defined as  $\frac{1}{2}(109^{\circ} 28' - \text{actual bond angle})$ , the factor of  $\frac{1}{2}$  being put in because the strain is spread over two bonds. Table -2 shows the angle strain for rings of different sizes.

Table 2

Angle strain in cycloalkanes

n	3	4	5	6	7	15
Strain	24°44'	9°44'	0°44'	(-5°16')	(-9°51')	(-23°16')

It is seen that decreasing angle strain in the cyclopropane - cyclobutane - cyclopentane series accounts for the decreasing heats of combustion shown in Table-1. However, the increase in strain postulated for cyclohexane (assumed to be planar and having bond angles of  $120^{\circ}$ ) is not in agreement with the especially low heat of combustion. It is now known<sup>15, 16</sup> that the strain theory does not apply to rings of six members and larger because such rings are puckered. Cyclohexane, in fact, exists in a completely strain-free chair form as evidenced by its "normal" heat of combustion. The high heat of combustion of the medium sized rings is due not only to angle strain but also to the existence of eclipsed conformations in these rings.

as well as to crowding of atoms across the rings. Large rings again have "normal" heats of combustion, as one might expect on the assumption that they begin to resemble open-chain compounds. Again this is contrary to the strain theory which would postulate large negative angle strains and presumably large heats of combustion per methylene group of such rings.

Equilibrium studies measuring thermodynamic stability of rings are unfortunately almost nonexistent. One of the few exceptions is the hydroxyaldehyde - hemiacetal equilibrium of sugars (Fig 4). The predominance of pyranose (six membered) over furanose (five membered) rings suggests that the former are more stable.

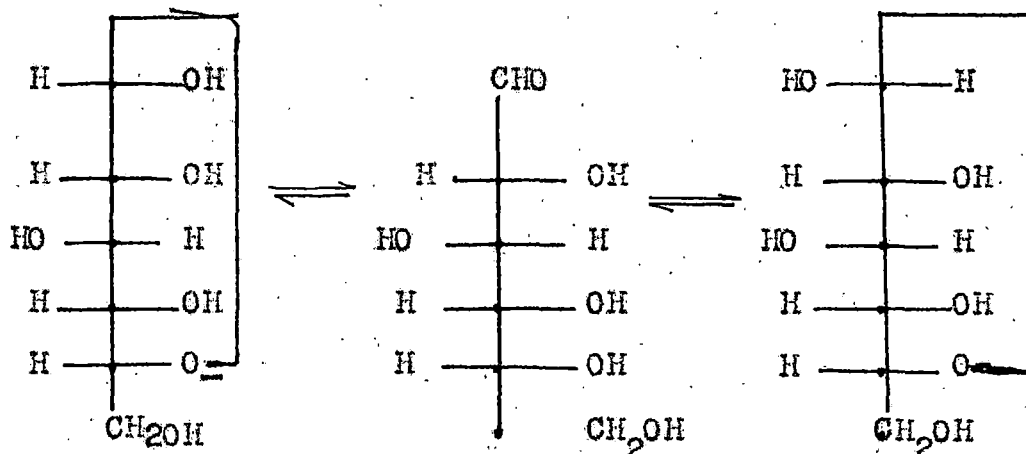

Fig 4

85956

17 AUG 1987

UNIVERSITY OF CALIFORNIA  
LIBRARY  
ANN ARBOR MI 48106

So far we have discussed the stability of saturated alicyclic systems. The question may be raised as to the effect of introducing elements of unsaturation, hetero atoms or other structural elements (such as phenyl rings) into the cycle. Unfortunately, very little thermochemical information on this point is available. The best we can do is to take stock of some systems that have been synthesized and are therefore stable enough to exist. Some of these systems are obviously quite strained. In a number of cases, the synthesis of similar systems of still greater strain has been attempted without success, and this fact will be noted. The inference should not be drawn, however, that because the synthesis of a given system has been unsuccessful in a single attempt or even in repeated attempts the system is too strained to exist.

In Fig. 5 are listed some ring systems containing unsaturation which have been synthesized. A double bond may be introduced even in the smallest of rings; cyclopropene (Fig 5 - I) and a number of its derivatives have been synthesized<sup>17</sup> despite the strain that would appear to be involved, and the system is even found in the naturally occurring sterculic acid<sup>18</sup> (Fig 5 - II). The supposedly even more strained cyclopropenone has been synthesized in the form of its diphenyl and di-n-propyl derivatives<sup>19</sup>

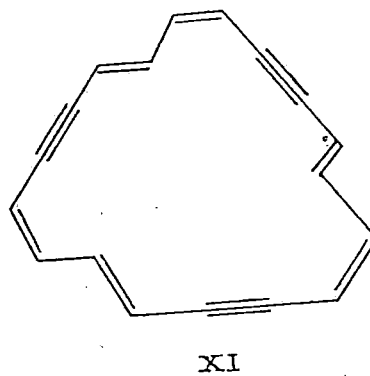
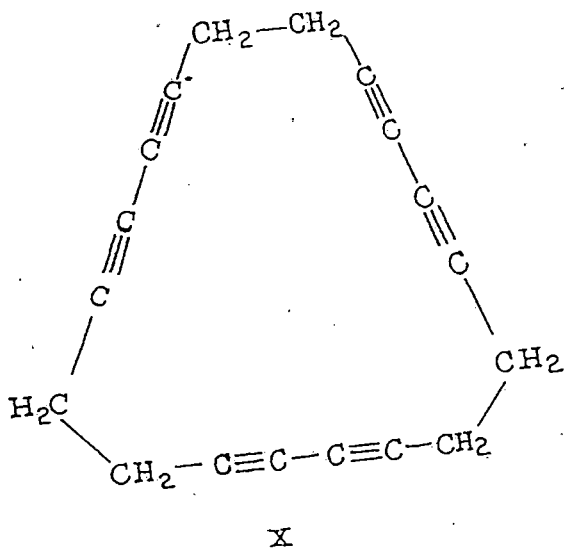
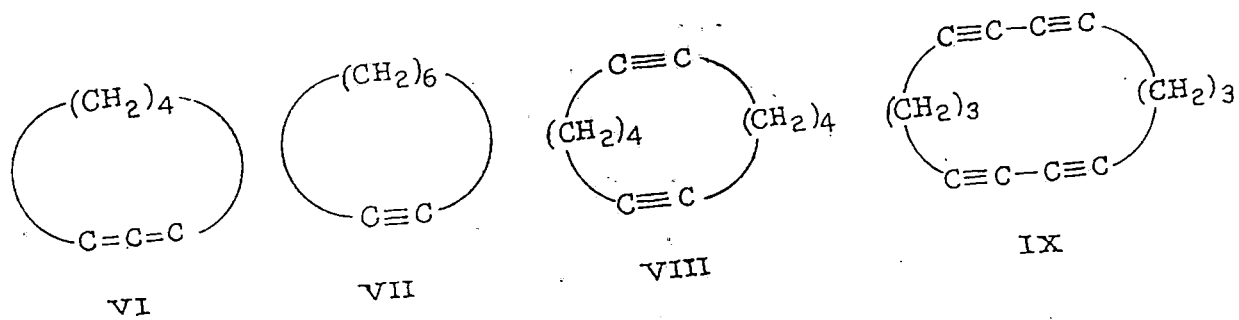
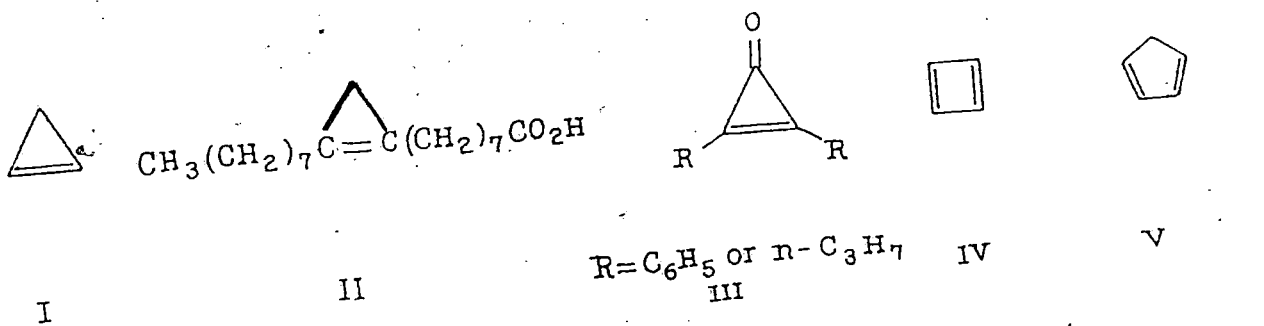

Unsaturated rings

Fig 5

(Fig. 5 - III); the system appears to be appreciably stabilized by having aromatic character. The smallest known cyclic diene, cyclobutadiene (Fig. 5 - IV)<sup>20a, b</sup> has been isolated as a silver nitrate complex<sup>21</sup>, the free hydrocarbon having very fleeting stability at best. The nickel chloride complex of tetramethylcyclobutadiene is also known.<sup>22</sup> Considerably greater stability is encountered in cyclopentadiene (Fig. 5 - V) although this hydrocarbon dimerizes on standing. Both 1,3- and 1,4-cyclohexadienes are known, but 1,2-diene (allenic) system was first claimed in 1,2-cycloheptadiene (Fig. 5 - VI).<sup>23</sup> The smallest cyclic acetylene whose synthesis has been reported<sup>24</sup> is cyclooctyne (Fig. 5 - VII).  $\square$  cyclohexyne has been claimed as a reaction intermediate; F. Scardiglia and J.D. Roberts, Tetrahedron, 13 343 (1957) 7. A 12-membered cyclic diyne (Fig. 5 - VIII)<sup>25</sup> and a 14-membered cyclic tetrayne (Fig. 5 - IX)<sup>26</sup> have also been obtained, the latter by oxidative dimerization of hepta-1,6-diyne.

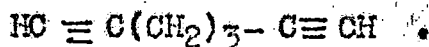

The next lower homologue, hexa-1,5-diyne,  $\text{HC} \equiv \text{CCH}_2\text{CH}_2\text{C} \equiv \text{CH}$ , would not yield the cyclic dimer<sup>26</sup> but did give cyclic trimers (Fig. 5 - X), tetramers and pentamers.<sup>27</sup> Treatment of the cyclic hexayne (Fig. 5 - X) with base converted it to the fully conjugated macrocycle XI which, in turn, upon mild catalytic hydrogenation gave the completely conjugated cyclic polyolefin cyclooctadecanonaene (Fig. 5 - XI, double instead of triple bonds),<sup>28</sup> a compound of considerable interest

because of its possible aromatic character.

A trans-substituted double bond can evidently not be accommodated in a small or common ring, but eight (as well as larger) trans cycloolefins have been synthesized,<sup>29</sup> and even the trans-trans form of 1,5-cyclooctadiene has been obtained.<sup>29</sup> Heats of hydrogenation, summarized in Table-3, indicate

Table 3

a  
Heats of Hydrogenation and Relative Stabilities<sup>b</sup> of cis and trans cycloolefins

Ring Size	Heat of hydrogenation		H° Kcal/ mole	F° Kcal/ mole
	Cis	Trans		
8	-11.98	-21.24	-9.26	-
9	-23.62	-26.49	-2.87	-4.04
10	-20.67	-24.01	-3.34	-1.86
11	-	-	0.12 <sup>c</sup>	0.67
12	-	-	-0.41 <sup>c</sup>	0.49

a. In acetic acid Ref 30

b. From Ref 31

c. From temperature dependence of equilibrium constants; from Ref 31.

greater thermochemical stability of the cis-cycloolefins as compared with the trans-isomers for 8-, 9-, and 10-membered cycles, the difference being by far the greatest for the eight

membered ring. In the 11- and 12-membered rings, there is little difference in enthalpy between cis and trans isomers.<sup>31</sup> Free energy also favours the cis-isomer in cyclononene and cyclodecene, but there is a slight predominance of the trans-isomer at equilibrium for cycloundecene and cyclododecene.<sup>31</sup>

In Fig. 6 are shown some cyclic systems containing benzene rings. Among the ortho-bridged benzene rings, benzocyclopropene is not known but benzocyclobutene (Fig. 6 (1)) has been synthesised.<sup>32</sup>

The higher homologues (Hydrindene, tetralin etc) are well known. Attempts to obtain benzocyclobutadiene (Fig. 6-II) resulted in the formation of the corresponding dimer<sup>32</sup>, and the lowest member of the cycloalkadiene is still indene (Fig. 6-III) although dibenzocyclobutadiene (biphenylene, Fig. 6-IV) is known.<sup>33</sup> Bridging of a benzene ring across the meta positions takes a considerably longer chain. A meta bridged resorcinol (Fig. 6-V) has been obtained<sup>34</sup> with seven methylene groups in the bridge (nine members in the bridge altogether); the lower homologue with an eight membered bridge could not be synthesized. However in compounds (Fig. 6-VI & VII) the meta positions were bridged by six- and five-membered chains, respectively.<sup>35-37</sup> The synthesis of compound (Fig. 6-VII) and others in the series showed some particularly interesting features; the route is indicated in Fig. -7. For  $n > 7$ , spectroscopic evidence indicated

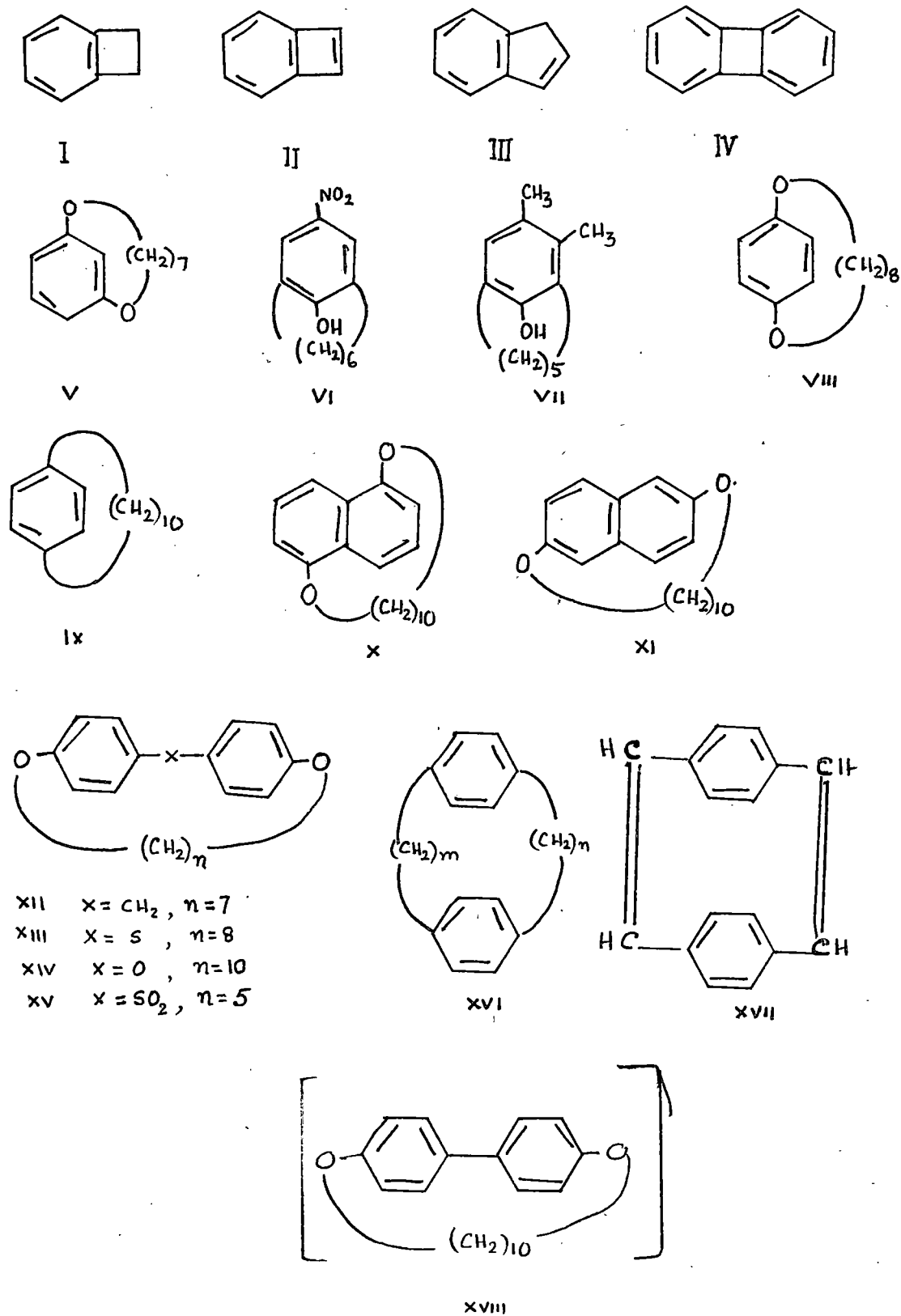
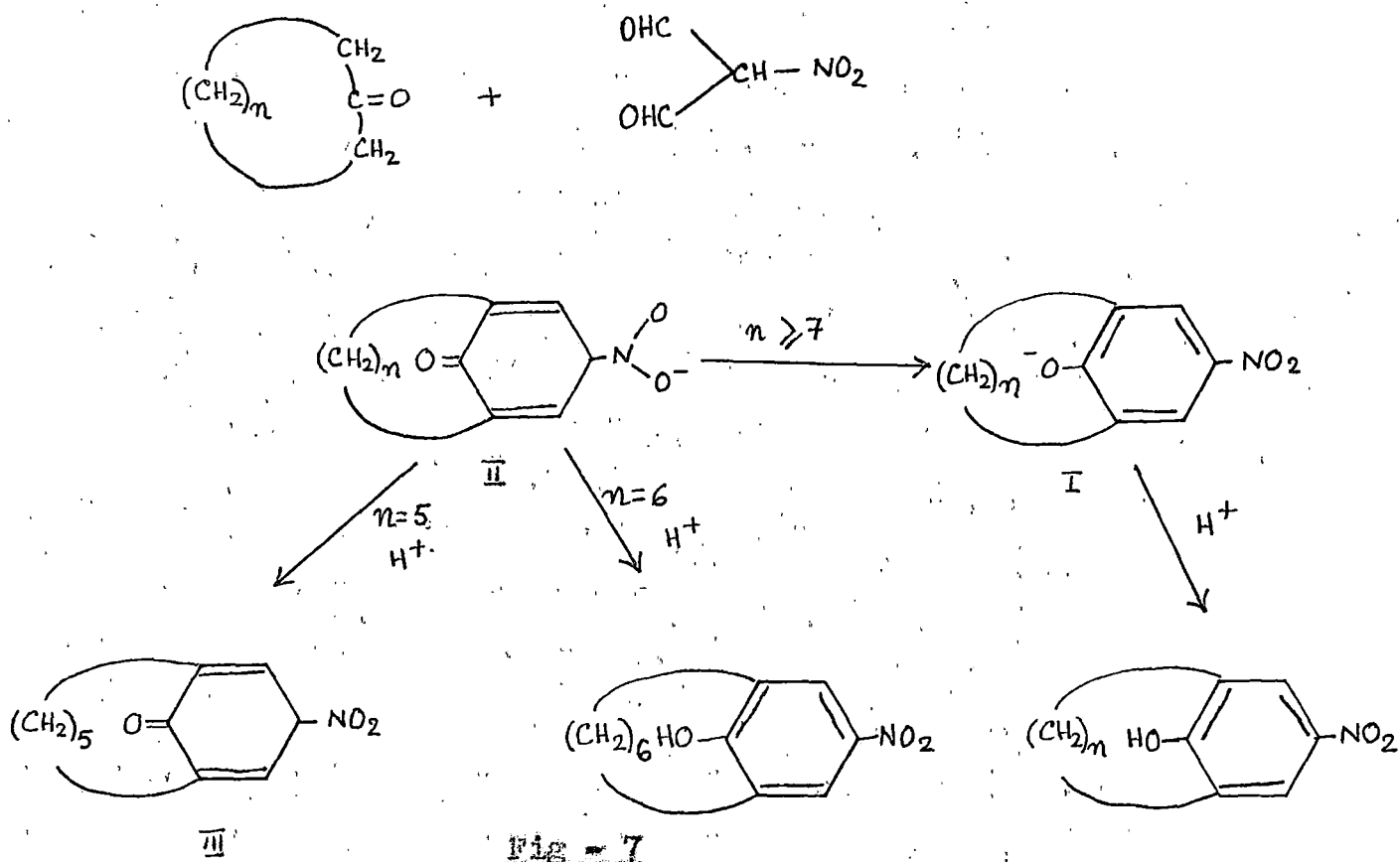

Fig. 6



that the anion obtained in the condensation was the p-nitrophenolate ion (Fig 7-I); with  $n = 6$ , however, the non-aromatic anion of the aci-form (Fig 7-II) resulted and reverted to the aromatic form only upon acidification. Finally with  $n = 5$ , the aromatic system was not formed even upon acidification, presumably because of excess strain; the product had the spectral properties of a dienone (Fig-7 - III). The ethers shown in Fig. 6 (XII - XIV) are of interest because the length of the bridge required to span the rings depends on the nature of the internuclear atom or group.<sup>40</sup> When X = methylene (XII), a heptamethylene bridge can be accommodated; for X = Sulphur

(XIII), the octamethylene-bridged compound was obtained (synthesis of the heptamethylene-bridged compound was not attempted but that of the hexamethylen-bridged compound failed); but when X=oxygen, the synthesis of the octamethylene-bridged compound failed and only a decamethylene bridge could be accommodated. With the sulphone (XV, X = SO<sub>2</sub>) a bridge of as few as five methylene groups could be constructed.<sup>41</sup> This variation of the ease of bridging has been ascribed<sup>42</sup> to the differences in bond angles at methylene and sulphur (110° to 112°) oxygen (129°) and sulphone (90°). However, the assigned C-O-C angle in the ether appears to be unreasonably large and the C-S-S angle in the sulphone unreasonably small; (values of 120° and 100° appear more likely; cf. L.E. Sutton, ed., "Tables of Interatomic Distances and Configuration in Molecules and Ions," The Chemical Society, London, 1958), it would appear that causes other than differences in bond angles must be partly responsible for the observed variations. Among such causes may be mentioned differences in bending-force constants including stiffening of the C-X bond by overlap of the 'p' electrons of X with the 'pi' electrons of the aromatic system.

A number of carbocyclic compounds containing two para-bridged benzene rings, called paracyclophanes (Fig. 6 - XVI) have been synthesized by D.J.Cram and co-workers. The smallest members of the series have<sup>43</sup> m = n = 2 and m = 1, n = 7.<sup>44</sup> The

smaller members present quite anomalous spectral properties suggesting strong interactions of the benzene rings with each other (so called "transannular interactions" because they occur across the rings). In the smallest ring ( $m = n = 2$ ) it has been demonstrated by X-ray diffraction studies<sup>45</sup> that the benzene rings are appreciably distorted from their normal planar shape. Other members of this family of compounds are the doubly unsaturated paracyclophanes (Fig 6 - XVII)<sup>46</sup> the meta-bridged analogue of XVI ( $m = n = 2$ ),<sup>47</sup> and paracyclophanes containing three<sup>47</sup> and four<sup>48</sup> aromatic rings. Attempts to prepare compound XVIII (Fig. 6) have failed,<sup>40c</sup> but the analogous compound with 'NH' instead of 'O' has been prepared<sup>48a</sup> even with a nonamethylene bridge.

In comparing oxygen containing cycles with carbocyclic compounds (e.g. V with VII; VIII with IX; and XVI,  $n = 1$ ,  $n = 7$ , with XII), it appears that the smallest known carbocycles of this type contain fewer ring members than their oxygen analogues. This difference, if real, may be due to the above mentioned variation in bond angles, bond bending force constants etc.

As a function of Ring substituents:<sup>49</sup>

There are numerous indications in the literature that, for a given ring size, alkyl substituents favour the ring form in an equilibrium involving the opening and closing of a ring, such as the equilibrium between a dicarboxylic acid and the corresponding cyclic anhydride, plus water (Fig-8).

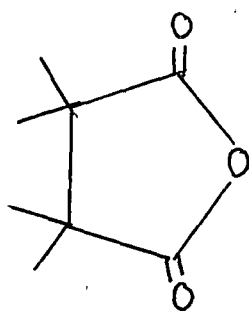
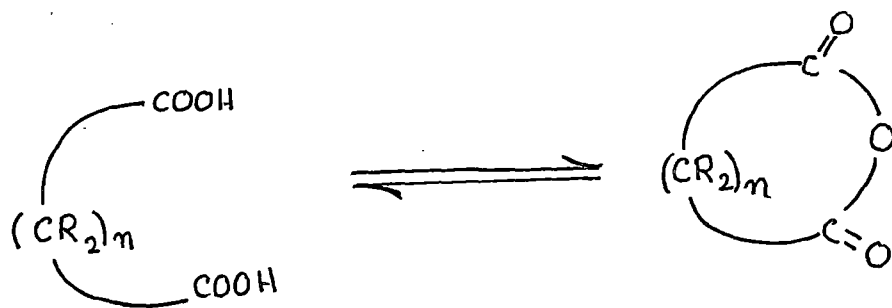

I

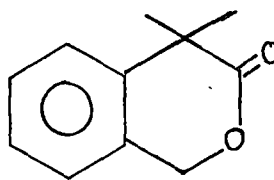

II

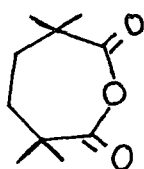

III

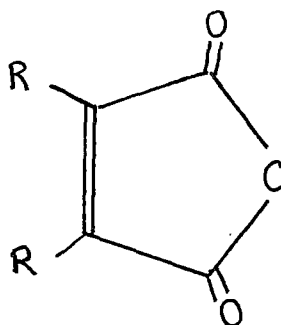

IV

DICARBOXYLIC ACID - CYCLIC ANHYDRIDE EQUILIBRIA

Fig - 8

Thus tetramethylsuccinic anhydride (Fig. 8, I) is formed by hydrolysis of esters of the acid with hydrobromic acid, by heating the acid with concentrated aqueous hydrochloric acid in a sealed tube<sup>50</sup> at 200°, and even by steam-distilling the acid,<sup>51</sup> dimethylhomophthalic anhydride (II) is obtained by the hydrolysis of the imide by aqueous hydrochloric acid,<sup>52</sup> and  $\alpha\alpha'\alpha'\alpha'$ -tetramethyladipic anhydride (Fig 8- III, seven-membered ring!) is not affected by hot water or aqueous sodium carbonate.<sup>53</sup> Furthermore, the dialkylmaleic acids exist only in the form of their anhydrides (Fig 8- IV, R methyl, ethyl, or phenyl) which are formed spontaneously upon acidification of aqueous solutions of the salts of the acids.<sup>54</sup>

∟ In all the cases the unsubstituted homologues (hydrogen instead of alkyl) have a much smaller tendency to form rings<sup>7</sup>

By way of explanation of these observations, Ingold and Thorpe<sup>55</sup> suggested long ago that the diminution of the internal angle in a small ring (e.g., 60° in cyclopropane) leads to a spreading apart of the external angle. This, in turn, relieves steric compression between substituents attached to one and the same carbon (FIG. 9), thus favouring the ring

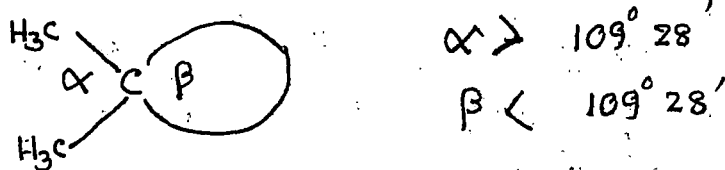

Fig. 9. Suggested bond angles in gem-dimethyl substituted cycloalkanes (Thorpe and Ingold)<sup>55</sup>

form over the open-chain form. This explanation is probably correct for small rings.<sup>56,57</sup> In common rings with their normal or nearly normal bond angles the theory fails, however, to explain the enhanced ring stability. Evidence against bond angle spreading is also found in the formation of macrocyclic rings from 2-2-bis(p-hydroxyphenyl)propane.<sup>58</sup> The phenolic groups in this compound could be spanned with a decamethylene or octamethylene bridge (Fig-10) with no

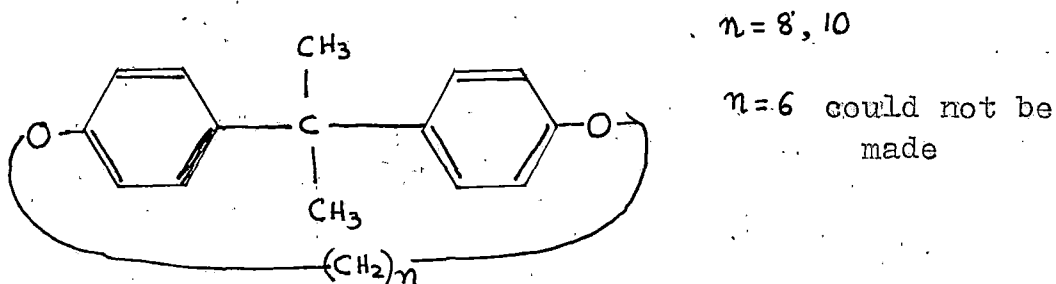

Fig. 10 Macrocycle with gem-dimethyl groups

greater ease than those in the parent compound having hydrogen atoms instead of methyl groups ( Fig. 6, XII); attempts to span them with a hexamethylene bridge failed, as they had with the unmethylated compound. It was argued that, if spreading of the methyl groups was desirable and was favoured by a decrease in the phenyl-CR<sub>2</sub>-phenyl bond angle, the system shown in Fig-10 might have been spanned with a smaller bridge than its unmethylated homologue.

A theory of the "gem-dialkyl effect" which appears to be applicable at least in the case of six membered rings has

recently been proposed<sup>59</sup> in terms of the enthalpies and entropies to open-chain vs ring compounds. Analysis of a number of specific cases of substituted hexanes on one hand and substituted cyclohexanes on the other hand discloses that there are fewer extra gauche interactions to the alkyl substituents in the cycles than there are in the open chains. This means that, compared with an unsubstituted chain, the substituted chain has a more favourable enthalpy of ring closure. There is, in addition, an entropy effect due to branching based on the fact that branching reduces the rotational entropy of open-chain compounds but cannot, of course, reduce the entropy of the ring compound very much, because the ring compound has little freedom of internal rotation to begin with.<sup>49a</sup> Thus the entropy factor also favours ring closure for the more branched compounds. Since branching both reduces the enthalpy and increases the entropy of ring closure and thus leads to an equilibrium more favourable to the ring structure. The effect has been calculated for a number of methyl-substituted cyclohexanes<sup>59</sup> and agreement with experimental thermodynamic data is remarkably good.

It is apparent from the heats of combustion per methylene in different cycloalkanes that compounds with medium sized rings (8-11 membered) are not simply intermediate between common and larger rings. ~~There is a marked increase in the heat of combustion per methylene for these rings.~~

~~st~~. While common and large rings generally differ little in chemical behaviour from their aliphatic counterparts, both saturated and unsaturated, the medium rings have specific features that are characteristic only of them and not encountered in any other class of organic compounds. Detailed reviews on medium rings are available in literature.<sup>60</sup> Medium rings are characterized by a high energy content (Fig. 11). Fig 11 clearly shows that 8 to 11 membered cycloalkanes have an increased energy content.

The models demonstrate that medium rings have no angle strain (Baeyer's strain) and are built up of staggered conformations, i.e., they are also free from Pitzer strain. The factor responsible for the increased energy content of such rings is the intramolecular overcrowding, as the result of which the non-bonded atoms are forced to arrange themselves at distances smaller than the sums of their van der Waals radii. This type of strain has been called the Prelog strain. The strain per one methylene group is 5.0 kJ/mole in cyclo-octane, 5.9 kJ/mole in cyclononane, 5.0 kJ/mole in cyclo-decane and 4.2 kJ/mole in cycloundecane. In cyclododecane the strain is only 1.5 kJ/mole per methylene group, which clearly indicates that this ring does not belong to the category of medium sized rings; it is the first representative of macro (or large) rings. A rather large body of data has been obtained on the conformations of medium sized rings.

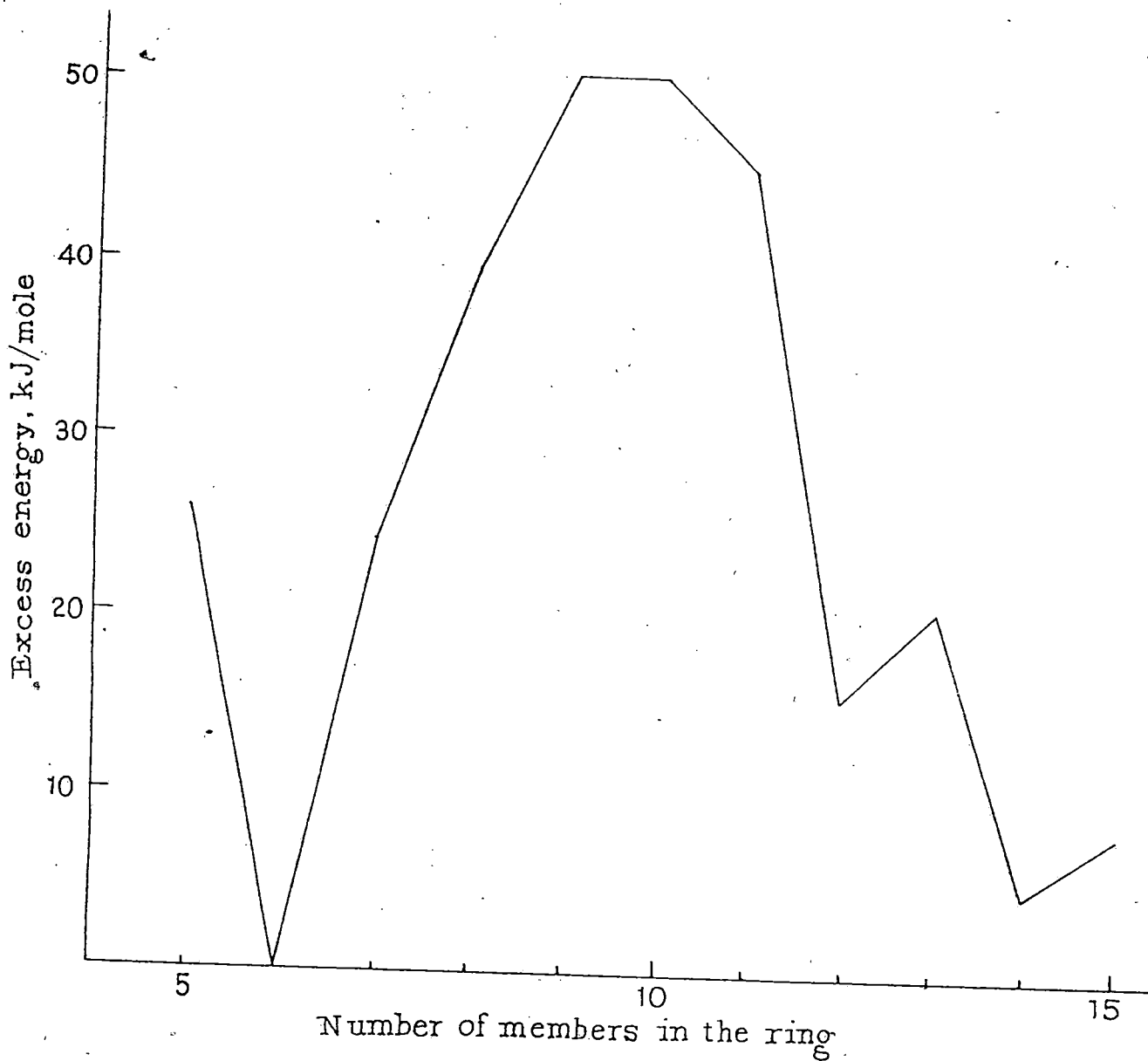

*Excess enthalpy of cyclic compounds (as compared with the infinite polymethylene chain) as a function of the number of carbon atoms in the chain, n.*

FIG - 11

The most probable conformation for cyclooctane was believed at one time to be the extended crown (12); more recent work has shown that there exists the boat-chair form (13) in the series of crystalline derivatives of cyclooctane.

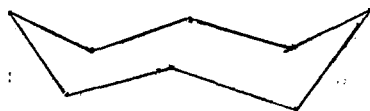

(12)

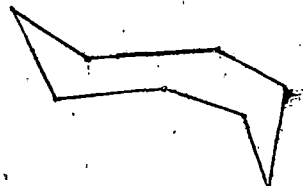

(13)

Similar conformations are also believed to exist for cycloheptane and cyclodecane;<sup>62</sup> the conformations of cyclononane are combinations of chair and twist-boat forms.<sup>63</sup>

We shall now examine, in more detail, the conformational features of cyclodecane, which is a typical representative of medium rings. In contrast to cyclohexane, all the carbon atoms of which are equivalent, in cyclodecane three different types of carbon atoms may be differentiated. The hydrogen atoms in cyclodecane may occupy six different positions (instead of two positions, axial and equatorial, in cyclohexane).

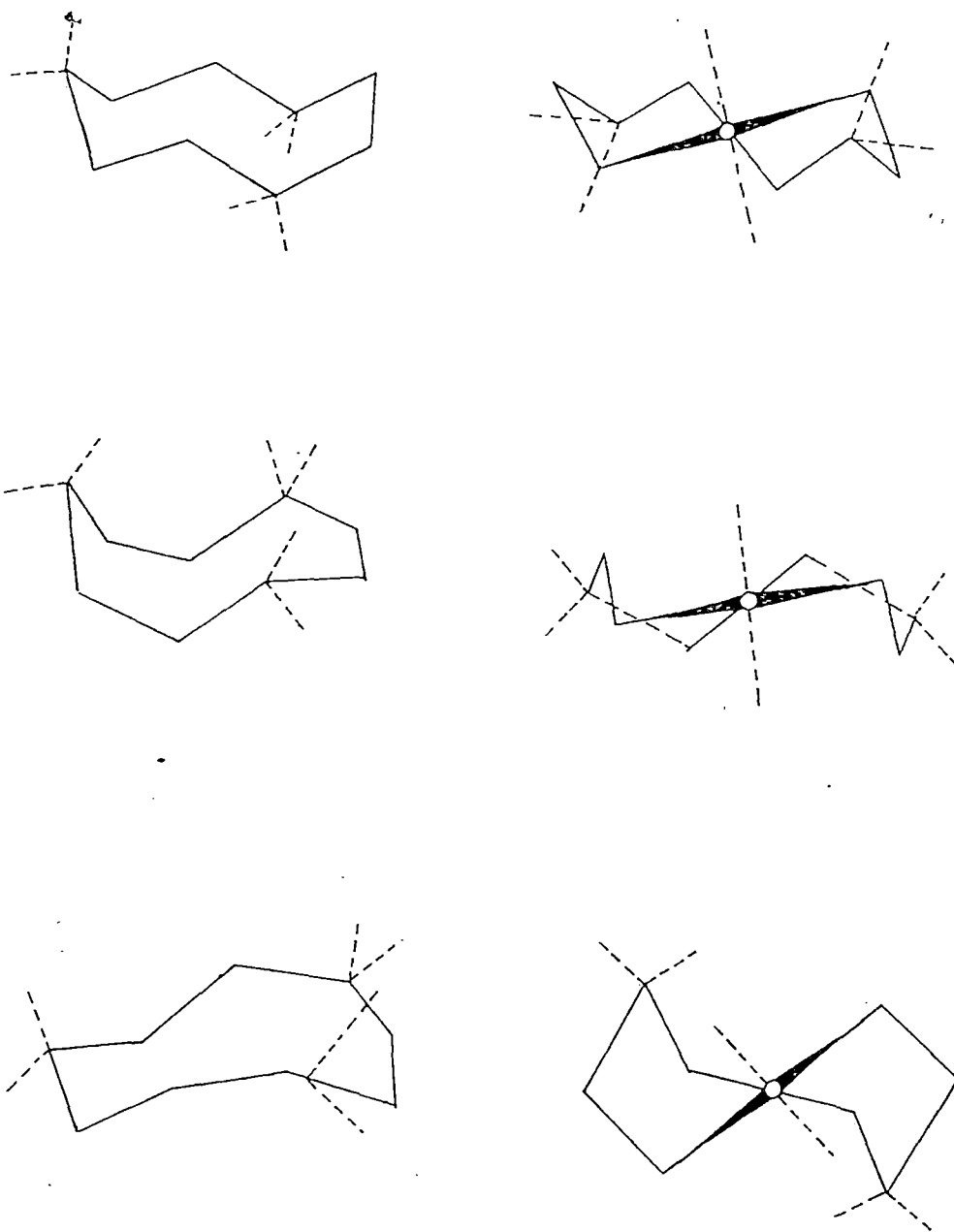

Fig 14

Conformations of cyclononane (p-31)

One of the important distinctive features of medium sized rings is the possibility of the existence of conformations in which some of the bonds of carbon atoms are directed into the ring. Such bonds and substituents are termed intraannular bonds or substituents; the bonds (and substituents) arranged outside the ring are called extra-annular or peripheral bonds (or substituents). Cyclodecane in its most favoured conformation has 6 intra-annular and 14 peripheral hydrogen atoms.

From this it follows that the  $\text{CH}_2$  groups in cyclodecane are stereochemically non-equivalent; among them are such groups in which both the hydrogen atoms are peripheral (type II-Fig 15); there are also such groups in which one atom is peripheral and the other is intraannular (types I and III). The last two types differ from each other in that in one case the peripheral hydrogen is equatorial (type I) and in the other it is axial (type III).

The intraannular hydrogen atoms are arranged in two layers (the upper and the lower) which form two superimposed triangles (Fig 15- the hydrogen atoms belonging to the same layer are connected by dashed lines). It is the intraannular hydrogen atoms that create intramolecular overcrowding which is responsible for the increased energy of the cyclodecane molecule.

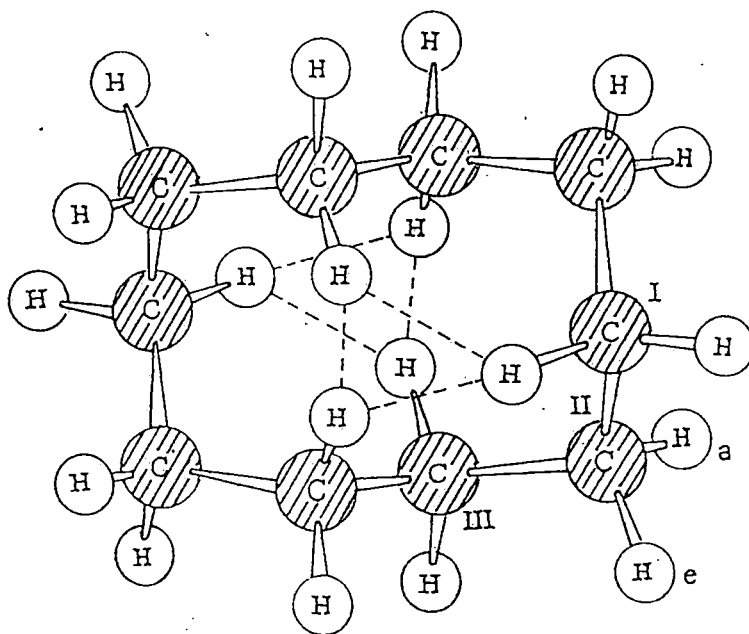

Fig - 15

The distances between intraannular hydrogens of the same layer, as determined from the model, are equal to 1.84 Å (the sum of the van der Waals radii being 2.4 Å). The experimental X-ray diffraction determination of these distances in a crystal of trans cyclodecane-1,6-diol gave the values 1.91 and 1.98 Å for the two conformations existing in crystals.<sup>64</sup> (Fig 16)

Substituents larger than hydrogen atoms cannot generally occupy intraannular positions. On monosubstitution there are seven conformers possible, three enantiomeric pairs (substituents in positions IIa, IIe, III) and one achiral conformer (substituent in position I). (Fig 15)

For cis 1,6-disubstituted derivatives there exists only one pair of enantiomeric conformers; for trans 1,6-disubstituted compounds there may exist four achiral conformers; it is believed that two of these conformers give rise to two crystalline forms observed for trans 1,6-diaminocyclodecane and for trans cyclodecane-1,6-diol mentioned in Fig 16. For 1,1,4,4-tetramethylcyclodecane there is only one favoured conformation in which all the methyl groups are extraannular. (Fig 17)<sup>65</sup>

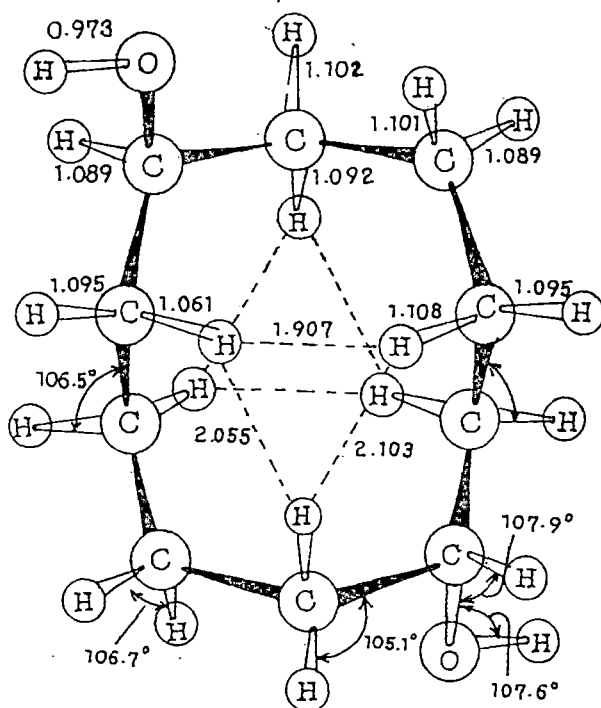

Fig - 16

The structural parameters of trans cyclodecane-1,6-diol according to X-ray diffraction data (the bond lengths are given in Å)

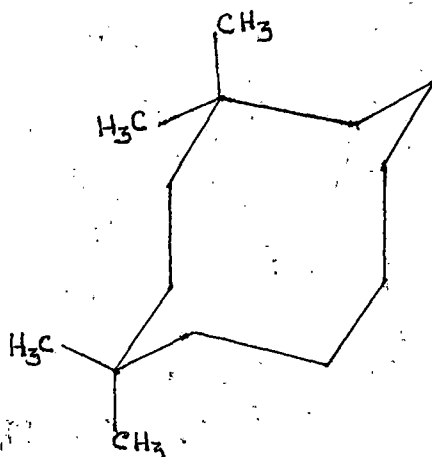

Fig - 17

The same conformation, with all the substituents being peripheral, may exist for 1,1,3,3- or 1,1,6,5-tetrasubstituted cyclodecanes. If the substituents are located in the 1,1,2,2- or 1,1,5,5- positions then one of them should have been intramolecular for the usual conformation of the cyclodecane ring. Since this would lead to a considerable increase of the energy of a molecule, the cyclodecane ring adopts a different conformation, which is observed for example, in the case of 1,1,5,5-tetramethylcyclodecane-carboxylic acid.<sup>66</sup>

Removal of one of the intramolecular hydrogens lowers the internal energy of cyclodecane, especially if this hydrogen belonged to an atom of type III (Fig 15). Therefore trigonal carbon atoms (the carbonyl group, the exocyclic double bond, the carbonium ion) or hetero atoms (nitrogen, oxygen) occupy a position of type III in a 10-membered ring.

This results<sup>67</sup> in a decrease of the distance between the two carbon atoms of type III (or, respectively, between the carbon atom and the heteroatom) which are on the opposite sides of the ring (in positions 1 and 5). For cyclodecane itself the corresponding distance is 3.29 Å, for cyclodecanone the CH - CO distance is 3.04 - 3.13 Å, and for 1-oxacyclodecan-5-one the O - CO distance is 2.83 Å.

The most interesting distinctive feature of the medium rings is the manifestation of transannular effects (also known as transannular interactions or proximity effects) and the occurrence of transannular reactions. These effects and reactions do not occur at the carbon chain and do not involve the neighbouring atoms; they take place between atoms on the opposite sides of the ring.

Transannular interactions are especially prominent in those compounds in which units of electrophilic and nucleophilic character are opposed in the ring. In this case, there may be observed "transannular neutralization", as, for example, in the molecule of the alkaloid cryptopine which contains a ten-membered ring. Analogous phenomena have been detected in the series of medium-ring azaacyloins.

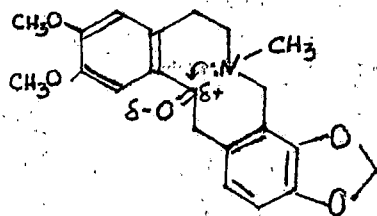

Cryptopine

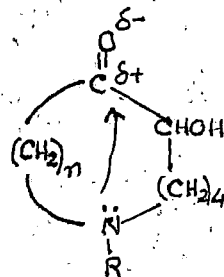

Azaacyloins

For optically active compounds of this type, the transannular interaction between nitrogen and the carbonyl group leads, in particular, to the weakening of the Cotton effect (characteristic of the carbonyl group) in the region of 300 nm.

In 1950, Prelog even suggested the idea that the decreased frequency of the vibrations of the carbonyl bond in the ir spectrum of cyclooctanone (about  $1690\text{ cm}^{-1}$  instead of  $1750\text{ cm}^{-1}$ ) could be explained by the formation of a transannular hydrogen bond to one of the ring hydrogens. To verify this suggestion, Allinger<sup>68</sup> obtained the partially deuterated cyclooctanes and cyclooctanones (18 to 21).

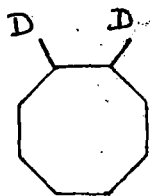

18

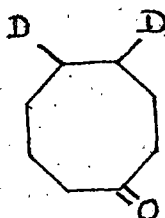

19

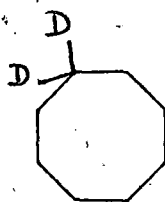

20

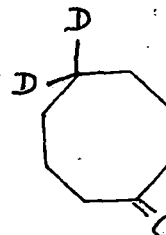

21

The investigation of the C - D frequencies in the ir spectra of these compounds has shown that they are identical for hydrocarbons (18) and (20) and ketones (19) and (21) which is indicative of the absence of an intramolecular hydrogen bond suggested by Prelog and makes more probable the explanation that takes into account the increase of the

$O=C$  angle in medium-sized rings as compared with the ordinary angle for the carbonyl group in the aliphatic chain.

The transannular interaction in 8- and 9-membered ring compounds of the type (22) has been detected by a change in the chemical shift of  $^{17}O$  in the carbonyl group  $^{17}O$  C if the ring contains, in addition, an oxygen atom or ~~the~~ group  $NC_2H_5$ <sup>69</sup>. It has also been found that the reactivity of this

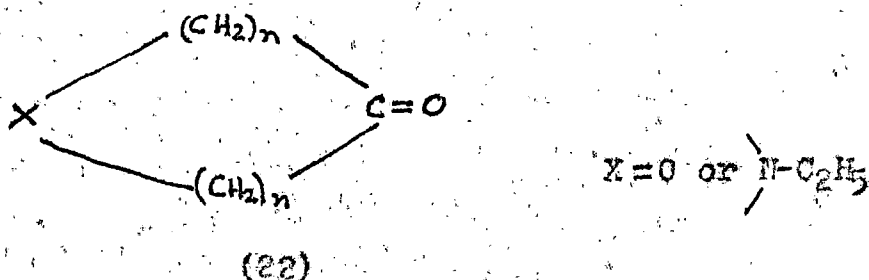

type of carbonyl group decreases in the hydration reaction. (also detected with the aid of  $^{17}O$ ) The rate of this

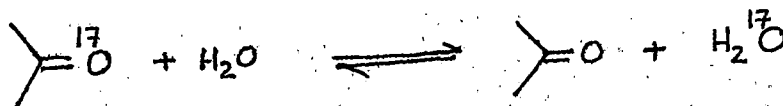

reaction decreases in going from six to ten-membered ring compounds; the presence of a hetero-atom X in a six-membered ring (22,  $n=2$ ) has no effect on the rate of the reaction. But in 8 to 10-membered rings the presence of a hetero-atom sharply lowers the reaction rate, as a result of a transannular

interaction.

An example of a specific transannular reaction is the oxidation of trans-cyclodecene (23) with performic acid, which was studied by Brelog in 1952. In this reaction, along with the normal product cyclodecane-1,2-diol (24), there are formed a number of other compounds, the most remarkable of which are cyclodecane-1,6-diol (25) and trans 1-decalol (26).

The reaction is believed to proceed via the intermediate cyclic non-classical cation (27) which either pulls a hydrogen atom with two electrons from position 6 or is stabilized by bond formation between C-1 and C-6 with elimination of H and formation of the bicyclic compound (28).

The cause of the formation of the transannular reaction products can be understood if one recalls the above considered specific features of the spatial structure of cyclodecane and the transiently formed cyclodecyl cation; in the latter, the positive charge of the carbonium ion centre next to the intraannular hydrogens that participate in the hydride shift.

The study of the acetolysis of the cyclodecyl tosylate (page 43) with the aid of labelled carbon has shown that this process too is accompanied by the hydride shifts of intraannular hydrogens from positions 5 and 6, since the entering acetoxy group does not occupy the place of its predecessor, the tosyloxy group. (The labelled carbon is indicated by an asterik).

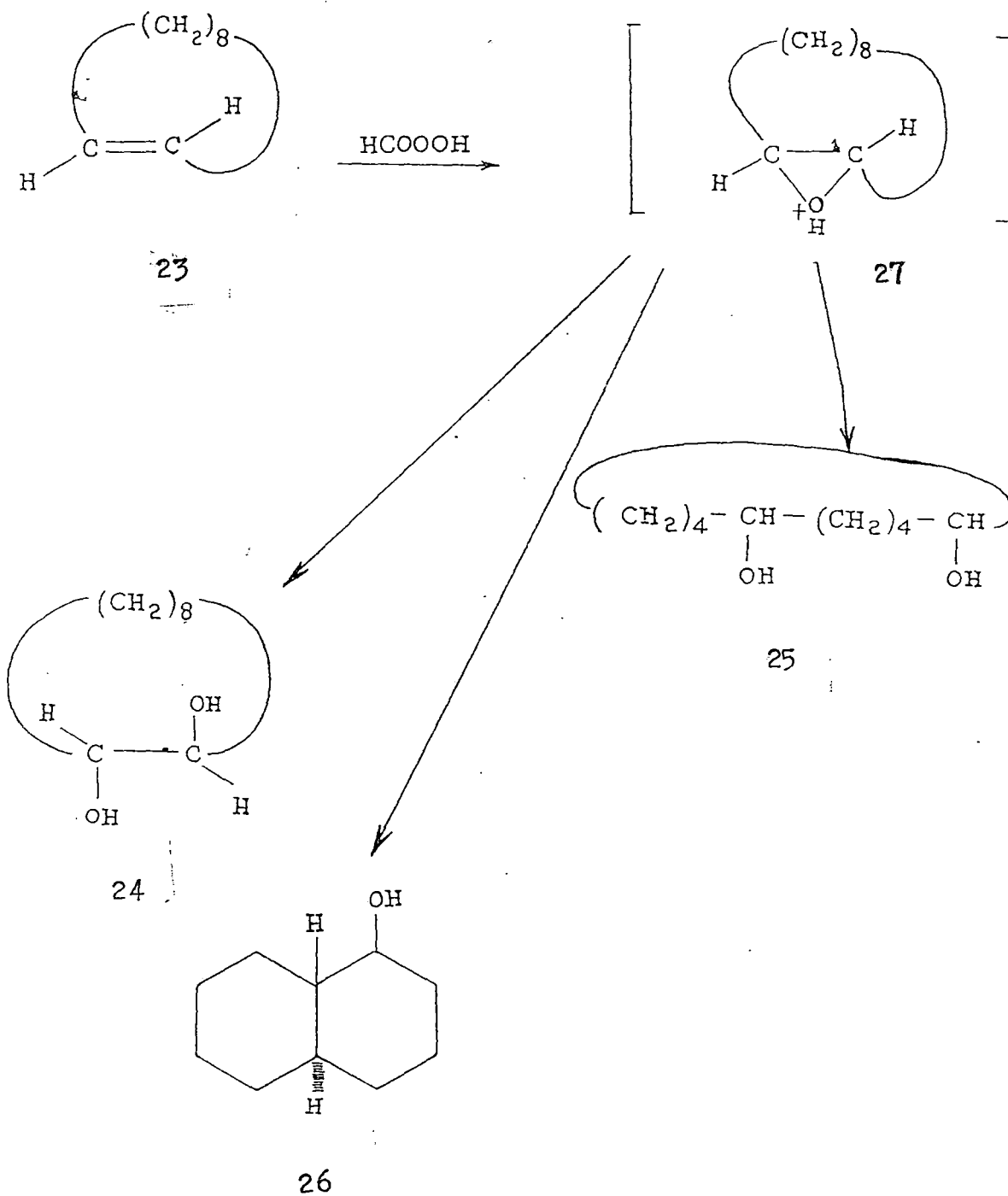

Reaction of ~~trans~~ Cyclodecene with Performic acid

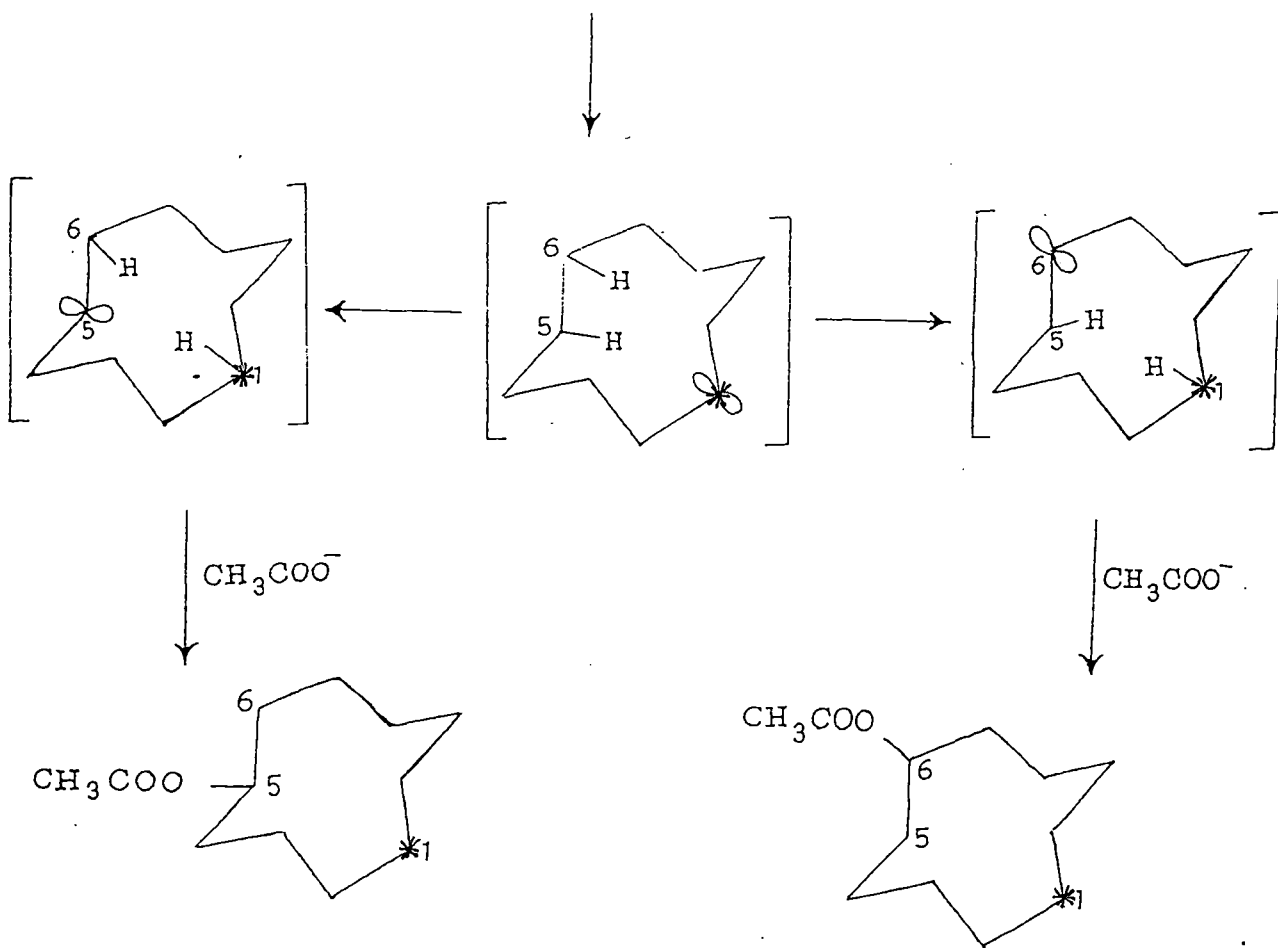
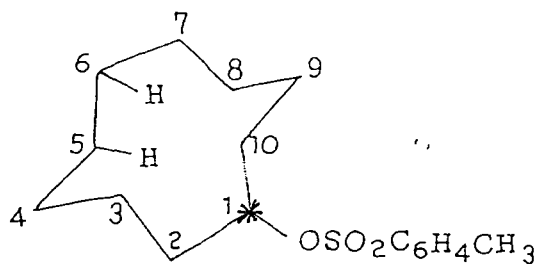

Acetolysis of cyclodecyl tosylate.

The hydride shift from positions 5 and 6 (relative to an atom where the carbonium ion centre is located) can be understood on the basis of the geometry of cyclodecane.

Transannular reactions in the cyclooctane series have also been described; for example,

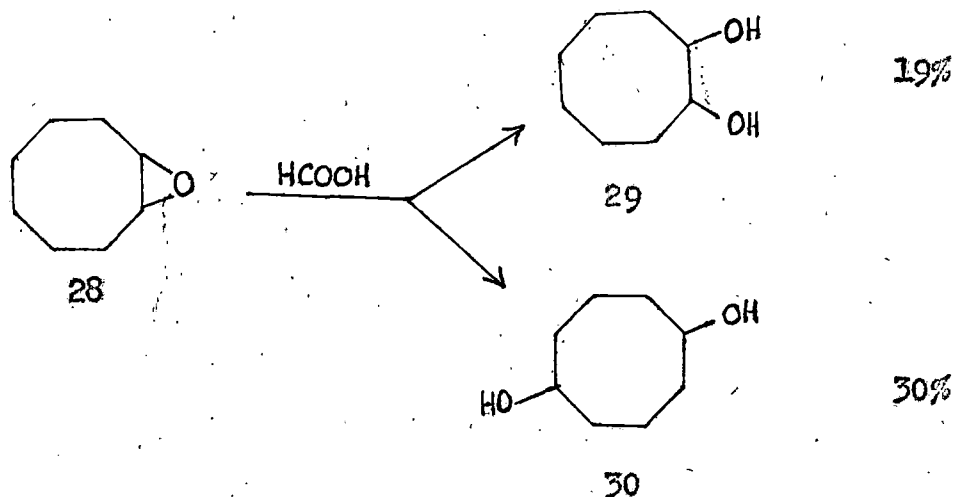

from cyclooctene oxide (28), under the action of performic acid, along with the normal reaction product (29) there formed the 1,5-glycol (30) as a result of a transannular reaction. This is a consequence of a hydride shift similar to that considered for cyclodecane.

The transannular reactions in medium-sized rings have been investigated by many other authors.

A characteristic feature of transannular interactions and reactions is their stereospecificity. This means that if the starting material is a certain stereoisomer, the product

of transannular reactions will also be, as a rule, a certain stereoisomer and not a mixture of isomers. This is not surprising since the occurrence of transannular interactions and reactions, as we have already seen, is closely related to the shape of the ring.

Transannular interactions are most pronounced in medium rings, but certain manifestations of such interactions may be encountered in other compounds as well. Thus, the signs of a transannular interaction of hydroxyl groups were detected in the analysis of the ir spectra of cycloheptane-1,4-diol series.<sup>70</sup> It is believed<sup>71</sup> that in cyclohexane too there takes place a transannular interaction between the substituents in positions 1 and 4. Some authors believe that a transannular migration of hydrogen may also take place in six membered rings.<sup>72</sup> The homoconjugation effect is also an interaction across the ring.

#### Methods for the Synthesis of Medium ring Compounds.

Some of the more common methods for the synthesis of ring compounds have already been discussed and it was pointed out that the acyloin method was the most useful method.

In spite of the versatility of the acyloin method, its limited applicability to the synthesis of unsaturated cyclic compounds with one or more double bonds in the rings, so highly

characteristic of naturally occurring medium ring compounds has led to the exploration of newer methods to accomplish this end.

The most important method available for the synthesis of medium ring compounds is by the ring expansion of easily available cyclic ketones by Tiffeneau - Demjanov<sup>73</sup> rearrangement of the derived 1-aminomethylcycloalkanols. In spite of the excellent overall yields, the formation of positional isomers from unsymmetrically substituted aminomethylcycloalkanols is a serious drawback of this method.

Other syntheses of medium ring compounds make use of bicyclic precursors. For example (31) or (32) can give cyclodecanedione by standard reactions. The obvious drawback of

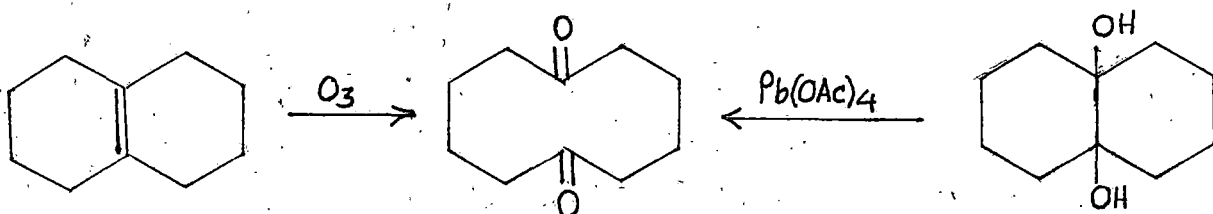

this approach lies in the poor yields and introduction of other functional groups is rather tedious if not impossible.

The facile cleavage of  $\beta$ -ketosylates<sup>74</sup> and  $\gamma$ -hydroxytosylates<sup>75</sup> in presence of bases giving unsaturated acids or ketones is yet another approach which has been successfully

exploited in the synthesis of medium ring compounds. For example 6-methylcyclodec-5-ene-1-one (33) was obtained<sup>75a</sup> by treating -1-mesyloxy-9-methyl-10-decalol (34) with potassium tertiary butoxide. The elegant synthesis of caryophyllene<sup>75b</sup> is another

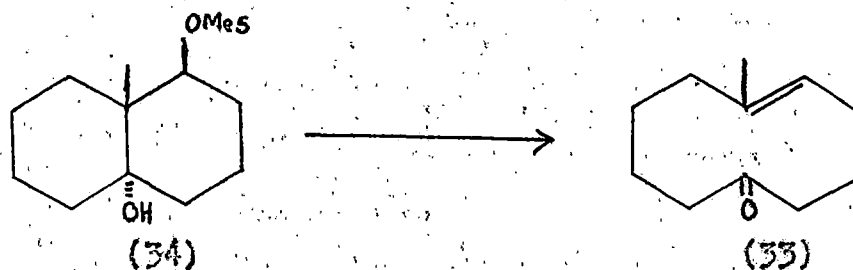

beautiful application of this approach. Elimination of halogen from properly constituted dihalides is also a useful method for the synthesis of larger rings from bicyclic precursors. Variations of this method are known, e.g., Miyashita *et al*<sup>76</sup> have prepared in 60% yield 1,7,7-trimethyl-trans-trans-1,5-cyclodecadiene (35) by treating the product of hydroboration of 5,5,9-trimethyl- $\Delta^4$ -octalin-1-yl methanesulphonate (36) with 10% aqueous sodium hydroxide - tetrahydrofuran solution at room temperature for 20 hours. In contrast the 3-hydroxy derivative (37) gave peripheral bond cleavage product (38) only, in 40% yield.

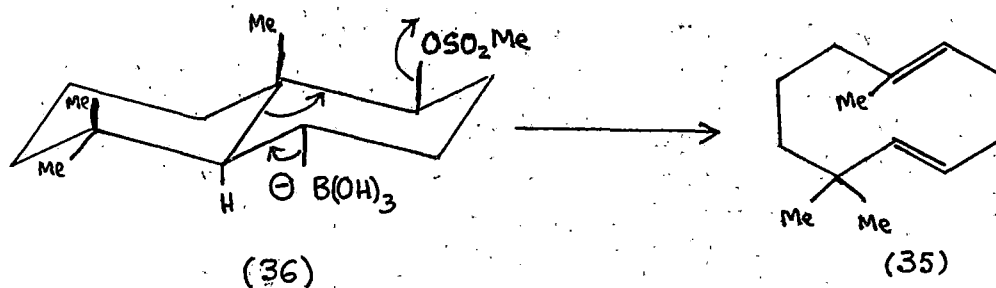



over a twostep mechanism (b) if the S-X bond and the free electron pair of the nitrogen atom were both oriented anti and parallel (antiperiplanar) with respect to C-C bond which undergoes cleavage.

Compounds such as 4-bromoquinuclidine (42) and 3-chlorotropane (43), which meet these requirements, actually fragment by the synchronous mechanism (a) as shown by their enhanced reactivity when compared with structurally similar cyclic halides not containing nitrogen atom.

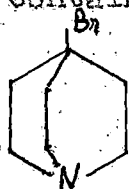

(42)

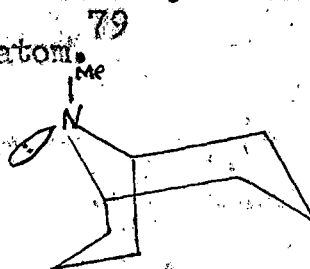

(43)

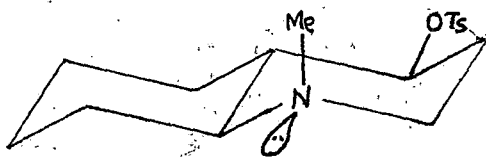

(44)

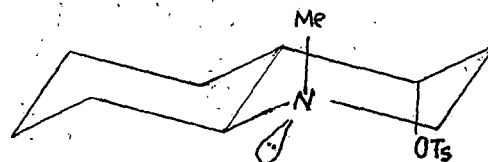

(45)

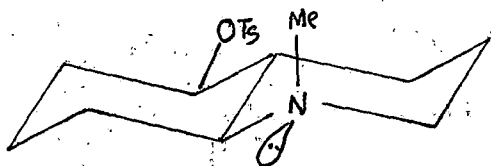

(46)

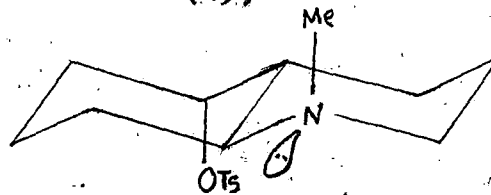

(47)

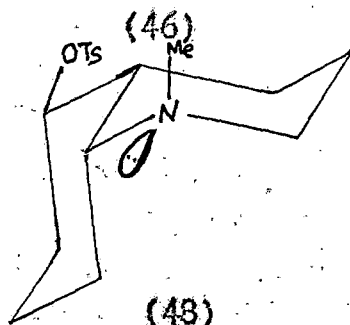

(48)

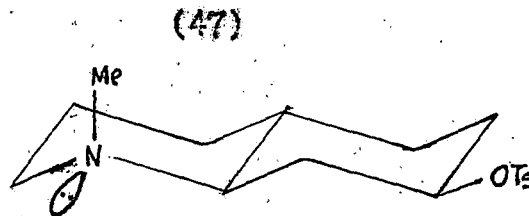

(49)

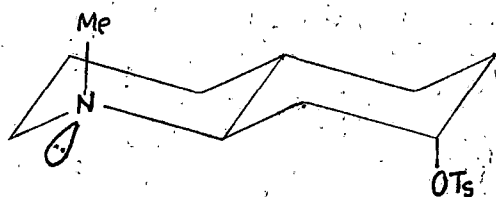

(50)

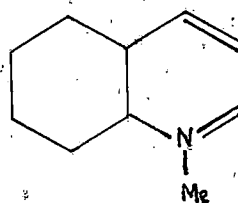

(51)

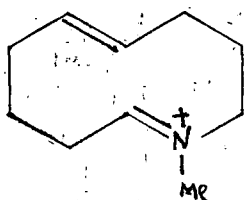

(52)

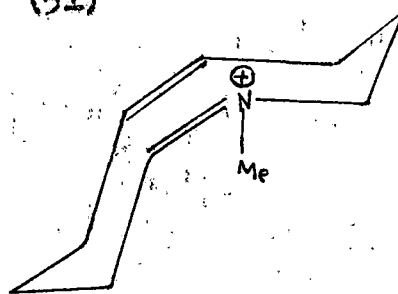

(53)



(54)

It remained to be shown that the synchronous mechanism would not be observable in cases where the C-X bond or N-electron pair or both are prevented from adopting the required orientation.

This has now been demonstrated by studying the solvolysis rates and the products of the stereoisomers of 4,5- and 7-tosyloxy-N-methyldecahydroquinoline (44) - (50) in 80% (v/v) ethanol and by comparing their first order rate constants with those of the corresponding 1- and 2-decalyl tosylates.

Thus the equatorial tosylates (44), (46) and (48), in which all the three electron pairs involved in the synchronous process (a) are able to adopt anti-periplanar orientation (indicated in the formulas by heavy lines and spots) afford exclusively the corresponding fragmentation products (51), (52) and (53) respectively. Furthermore, the solvolysis rates of (44), (46) and (48) are 4870, 46 and 56 times those of the corresponding alpha-decalyl tosylates, respectively. The synchronous nature of the fragmentation process is also reflected in the stereospecific formation of a trans and a cis-olefinic bond in the strained products (52) and (55) from (47) and (48) respectively.

Conversely, the axial tosylates (45) and (47) in which the C-O<sub>2</sub>S bond is no longer anti and parallel to the C-C bond, react at rates comparable to those of the corresponding axial 1-decalyl tosylates. In accordance with a reaction by way of a carbonium ion, the tosylate (45) yields an elimination product ( $\Delta^{4,10}$ -N-methyloctahydroquinoline) besides fragmentation product (51), whereas the tosylate (47) affords substitution (alcohol and ether) and elimination products ( $\Delta^{5,10}$ -N-methyloctahydroquinoline) only.

In the equatorial 7-tosyloxy derivative (49) the N-electron pair is unable to adopt a position anti-periplanar with the C-C bond, since it is constrained to oscillate in a plane perpendi-

cular to the ring. In the case of the 7-tosyloxy derivative (50) the C-OTs bond as well as the N-electron pair are no longer anti-periplanar with respect to the C-C bond. Both tosylates, as predictable on stereoelectronic grounds, react more slowly than the corresponding equatorial decalyl tosylates and afford substitution and 1,2-elimination products only. Therefore, even in a two-step process via the carbonium ion (54) fragmentation is prevented by a departure from an anti-periplanar orientation of the N-electron pair with respect to the C-C bond.

In reactions of the type (a) and (b) proceeding via an intermediate anion, fission is the preferred reaction in the cyclohexane series.

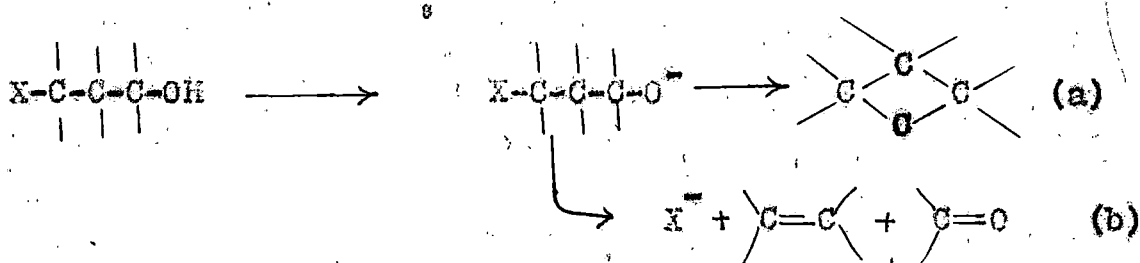

The difficulty in forming 1,3-epoxycyclohexane may be due to the additional steric strains which have to be created: the four membered oxide ring is approximately perpendicular to the remainder of the cyclohexane ring which becomes altered so that the atoms C<sub>1</sub> to C<sub>5</sub> become nearly coplanar and roughly in position to those in comparison to a cyclopentane ring. This distortion of the normal chair form of cyclohexane ring causes increased hydrogen eclipsing, especially in the C<sub>2</sub>, C<sub>5</sub> and C<sub>4</sub> groups. Such eclipsing probably contributes largely to the

greater heat of combustion per methylene in cyclopentane (158.7 Kcal/mole) than of cyclohexane<sup>60,61</sup> (157.4 Kcal/mole).

Crow<sup>82</sup> et al. have discussed the stereochemical requirements in heterolytic fragmentation reaction of the type:

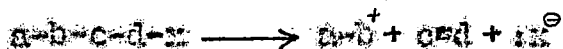

The geometry of the d-x bond and that of the electron donation group "a" relative that of b-c bond is critical. They arrived at this conclusion from a study of solvolysis rates and products of stereoisomeric 1-methyl-4,5- and 7-decahydroquinolyltoluene-sulphonates, in 30% ethanol.

The equatorial 4 $\alpha$ - and 5 $\alpha$ -trans tosylates (55) and (57) and the equatorial 5 $\alpha$ -cis tosylate (59), the C-O<sub>2</sub>S bond and the free electron pair on nitrogen are fixed in an anti-periplanar fashion with respect to the C-C bond. All the three compounds undergo quantitative and stereospecific fragmentation. Since they also react more rapidly than "homomorphous" 1-decalyl tosylates, a synchronous mechanism is indicated. The rate of enhancement due to the synchronous mechanism (fragomeric effect) varies with the stability of the fragmentation product formed in the transition state.

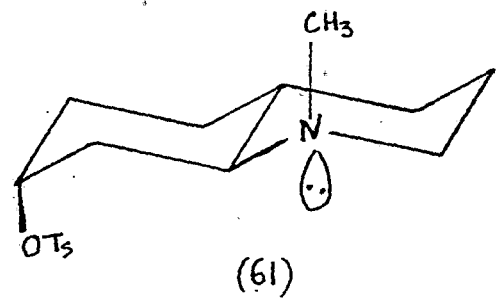
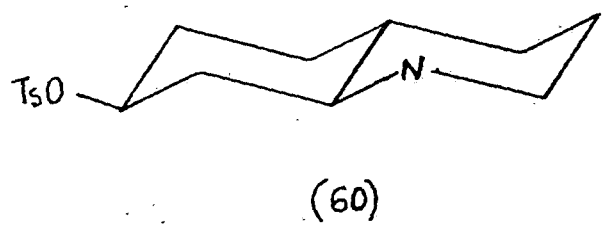
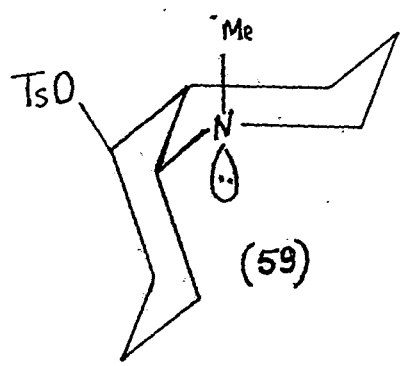
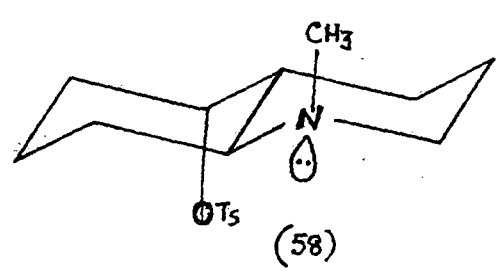
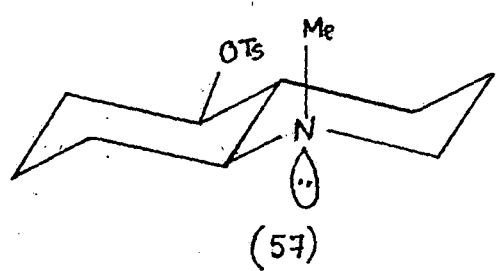
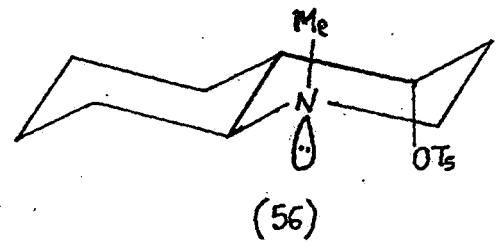
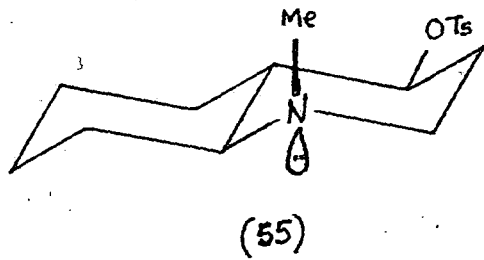

By contrast, the axial  $5\alpha$ - and  $7\alpha$ -tosylates (58) and (61) as well as the equatorial  $7\beta$ -tosylate (60) in which an anti-periplanar alignment of the electrons on nitrogen and in the C-OTs and C-C bonds is sterically excluded, react by the unimolecular substitution and elimination mechanism ( $S_N1-E_1$ ) only. Ionization rates are 2 to 3-times lower than those of homomorphous 1- and 2-decalyl tosylates due to the rate decreasing inductive effect of nitrogen.

The  $4\beta$ -trans tosylate (55) is exceptional in that fragmentation is accompanied by elimination. The rate product relationship indicates concurrent unimolecular elimination by way of the predominant all-chair conformation (55), and synchronous fragmentation via the skew boat conformation (62) of piperidine ring.

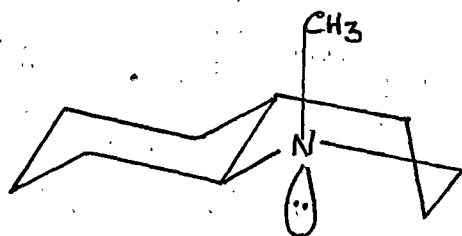

(62)

Wharton and Niegel<sup>85</sup> had studied the stereochemical requirement for the fragmentation reaction of 1,10-decalindiol monotosylate, leading to the formation of cis and trans cyclo-decenones.

The four 1, 10-decalindiol monotosylates (63) - (66) (OTs) were subjected to the action of potassium butoxide<sup>+</sup> in tert. butanol for one hour at  $40^\circ$ . Monotosylates (64) and (65)

(OTs) were individually converted in high yield ( $\approx 90\%$ ) to trans cyclodecenone (trans-5)<sup>84, 85</sup> and (66) (OTs) was converted in similar yield to cis-5-cyclodecenone (cis-5)<sup>85a</sup>. The results are in accord with the concerted breakage of antiperiplanar ( $180^\circ$ ) bonds "a" and "b".

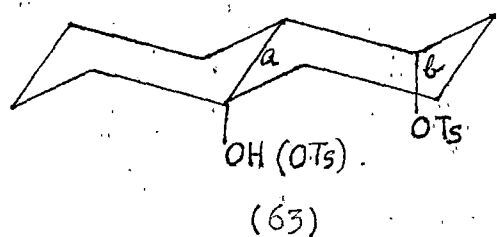

Complex mixture from elimination of TsOH containing no cis-5 and  $< 6\%$  of trans-5.

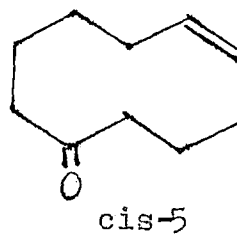
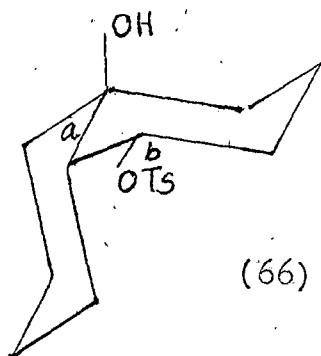
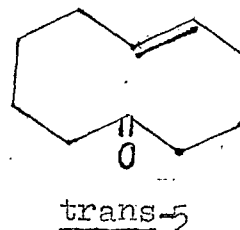
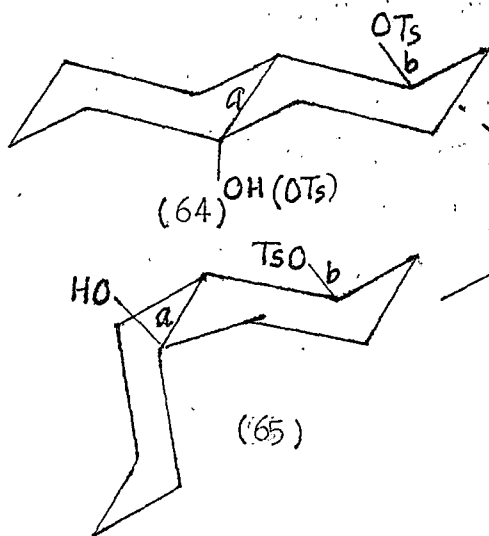

The stereospecificity of each is evident from detection by capillary vapour phase chromatography of no more than 0.2% of the unexpected isomer of 5-cyclodecenone in each product.

The importance of geometry is also emphasised by the different behaviour on treatment with base of (63) (OTs) in which bonds "a" and "b" are necessarily synclinal<sup>86</sup> ( $60^\circ$ ), subjected to the same condition used to fragment (64)-(65) (OTs), (63) (OTs) yielded a product which contained much unreacted tosylate. Under more drastic conditions using sodium methyl sulphanyl carbanion<sup>75b</sup> or prolonged butoxide<sup>t</sup> treatment (63) (OTs) disintegrated with loss of tosylate to a mixture of products containing no detectable cis-5, the product expected from a concerted, albeit difficult fragmentation. Analysis of the product by infrared spectroscopy and capillary V.P.C were, however, consistent with the presence of 6% of trans-5 which might be expected from non-concerted fragmentation via a carbonium ion.

SCOPE AND PLAN OF THE PRESENT WORK, RESULTS

AND

DISCUSSION

A survey of the different approaches to medium ring compounds reveals that one of the best approaches makes use of suitable bicyclic precursors. Base catalysed ring opening reaction of hydroxytosylates is one such approach. The starting materials (67) can be conveniently prepared from the olefines (68) via the derived epoxides. Though reactions

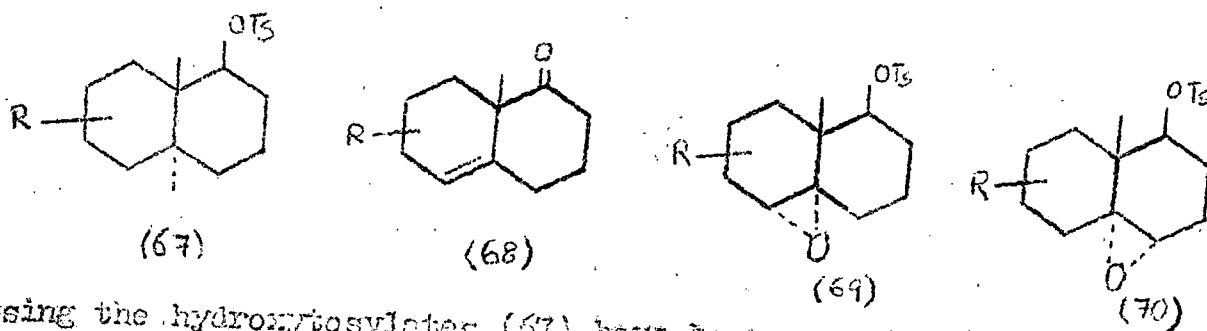

using the hydroxytosylates (67) have been reported in literature it appears that action of bases on epoxides of the type (69) and (70) which might also lead to similar fragmentation products has not been studied. For example, a base can attack the

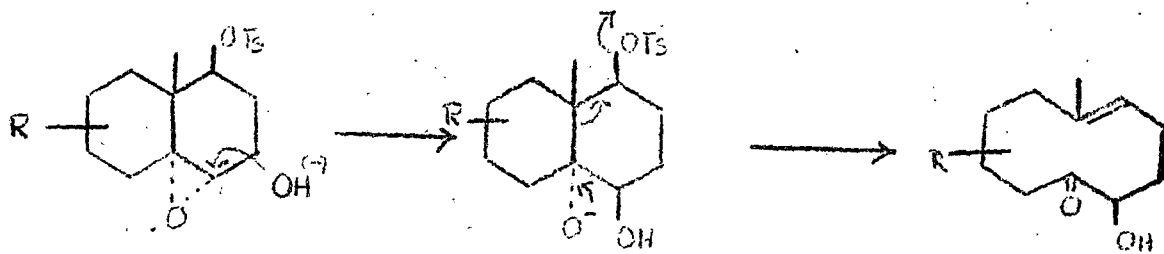

epoxide ring as shown and generate an alkoxide ion which can

eliminate the tosyloxy group as shown above yielding an unsaturated monocyclic acyloin.

If an oxo group is present in conjugation with the oxirane ring system, some more interesting possibilities can be envisaged. For example, House and Gilmore<sup>87</sup> have reported that 2,3-epoxycyclohexanones undergo Favorskii rearrangement. When piperitone oxide (71) and isophorone oxide (72) were reacted with bases, different products were obtained.

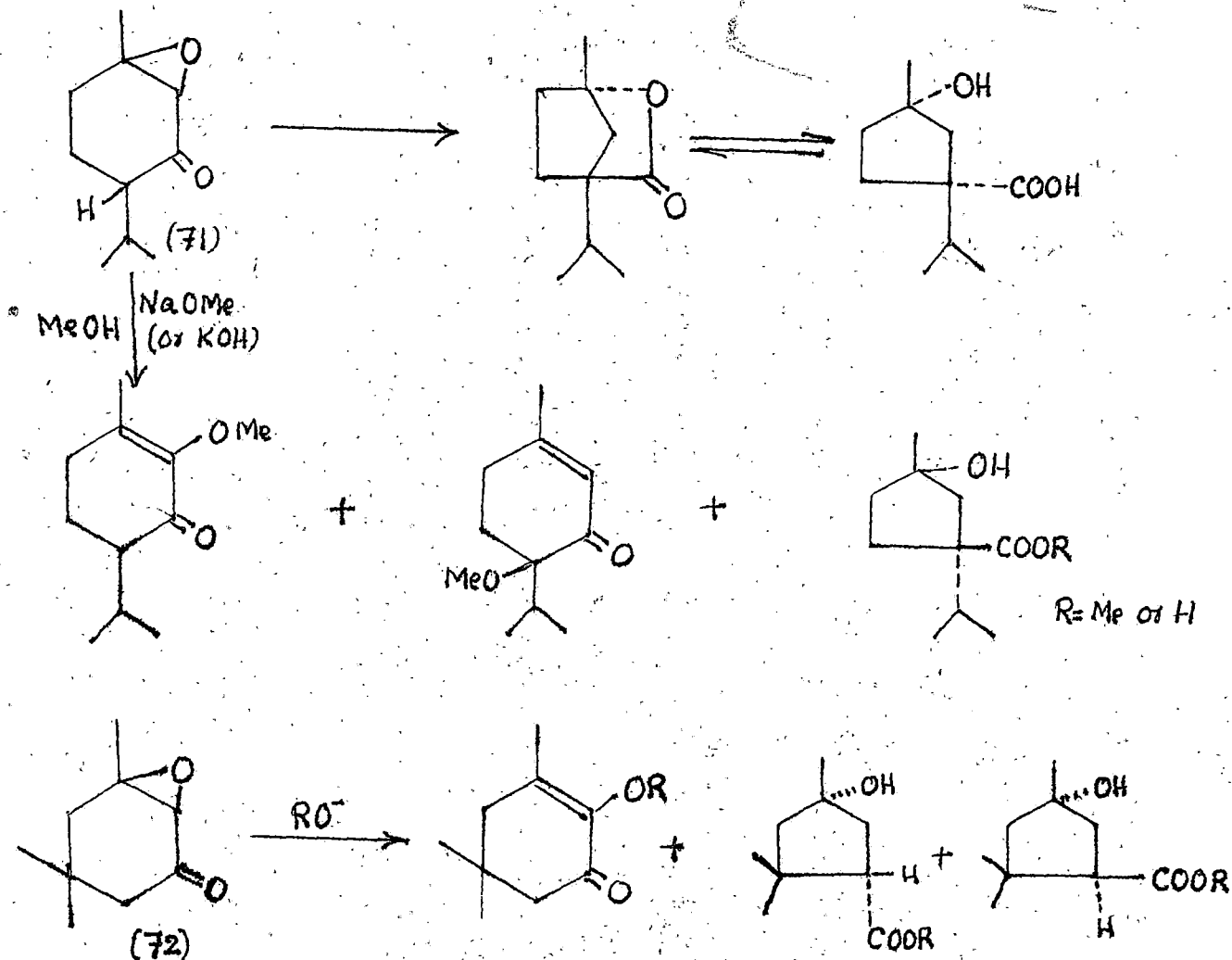

The different hydroxycyclopentanecarboxylates are obviously Favorskii rearrangement products. Thus, we argued, in case of oppositely substituted bicyclic epoxyketosylates Favorskii rearrangement followed by ring opening is a reasonable possibility. For example, (73) can give the different products outlined below.

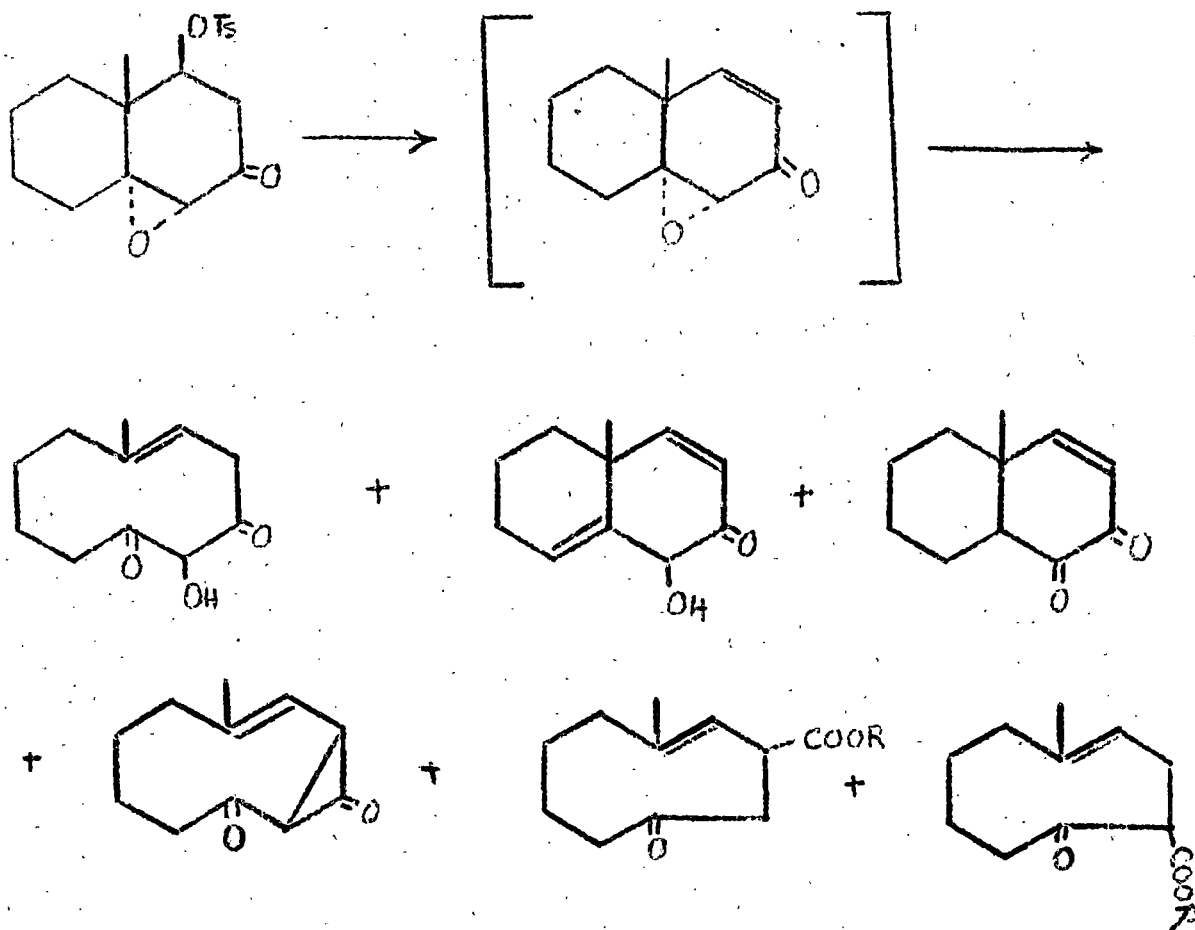

In order to test our hypothesis we synthesized 1-tosyl-oxymethyl-5 $\alpha$ ,6 $\alpha$ -epoxybicyclo [4.4.0]decan-4-one (74), 1-tosyloxymethyl-6 $\alpha$ ,7 $\alpha$ -epoxybicyclo [4.3.0]nonan-8-one (75) and 2-tosyloxy-1,3,3-trimethyl-6 $\alpha$ ,7 $\alpha$ -epoxybicyclo [4.4.0]decan-8-one (76) as follows.

Ethyl cyclohexanone-2-carboxylate (77) was prepared by

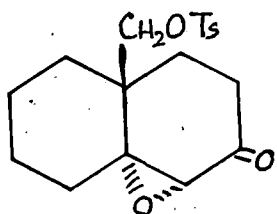

(74)

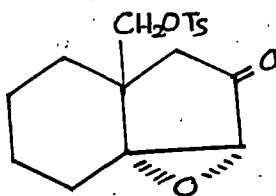

(75)

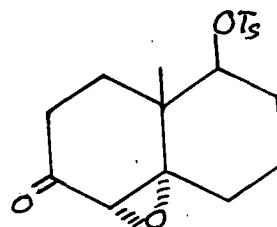

(76)

condensing diethyl oxalate with cyclohexanone in presence of sodium ethoxide followed by decarbonylation. Condensation of the methiodide of diethylaminobutanone with the enolate of ethyl cyclohexanone-2-carboxylate gave in 75% yield ethyl 2-(3'-oxobutyl)-cyclohexanone-2-carboxylate (78). Cyclization with sodium ethoxide of the diketone (78) gave the octalone (79) in about 66% yield. (2,4-dinitrophenylhydrazone m.p. 118°C<sup>88</sup>). Ketalization of the octalone (79) according to Dreiding and Tomasewski<sup>88</sup> led to the formation of a lot of high-boiling material and the desired ketal (80) was obtained in about 50% yield. By using just 1.2 equivalent ethanediol and a catalytic amount of p-toluenesulphonic acid, the yield of the ketal was greatly improved. Reduction of the ketal

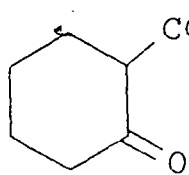

(77)

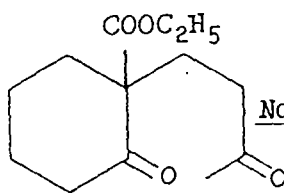
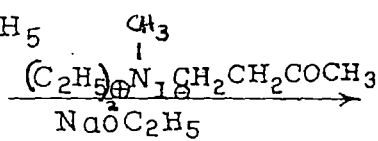

(78)

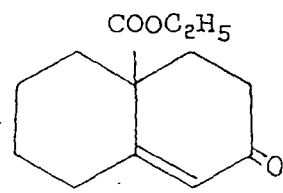

(79)

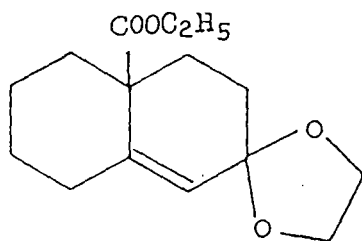
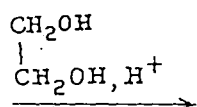

(80)

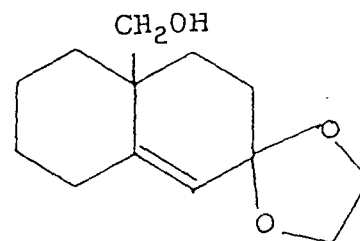

(81)

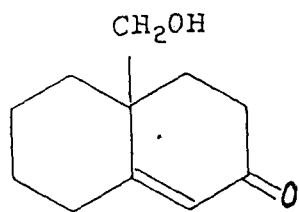
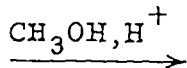

(82)

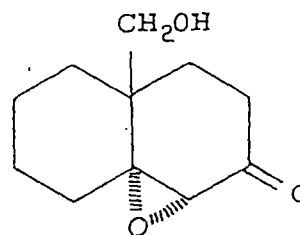
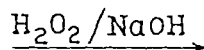

(83)

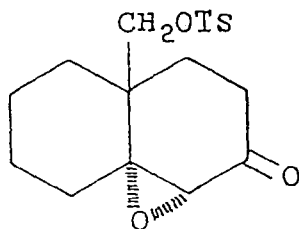
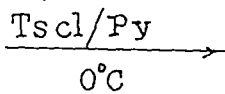

(74)

with Lithium aluminium hydride gave the ketal alcohol (81) as a white solid melting at 70°C.

Deketalization by refluxing with MeOH + HCl gave the unsaturated keto alcohol (82). (2,4-dinitrophenylhydrazone, m.p 155°) Treatment with alkaline hydrogen peroxide gave the epoxyketoalcohol (83). (I.R 3480, 1720 cm<sup>-1</sup>; m.p. 80°C). Careful treatment with redistilled p-toluenesulphonyl chloride in pyridine at 0° gave the epoxyketotosylate (74) (I.R. 1720 cm<sup>-1</sup>) m.p. 98°C.

The compound on treatment with sodium hydroxide at 0° for three hours gave a mixture of products from which could be isolated in about 20% yield a pleasant smelling liquid b.p 145<sup>9</sup>/<sub>2</sub>Torr m/e 196.

The compound which was isolated may have any one of the following structures, (84) to (89). A base may attack any or all of the indicated positions simultaneously or discretely depending upon its size, concentration and other reaction conditions. Attack of the base on 2 and 3 positions will result

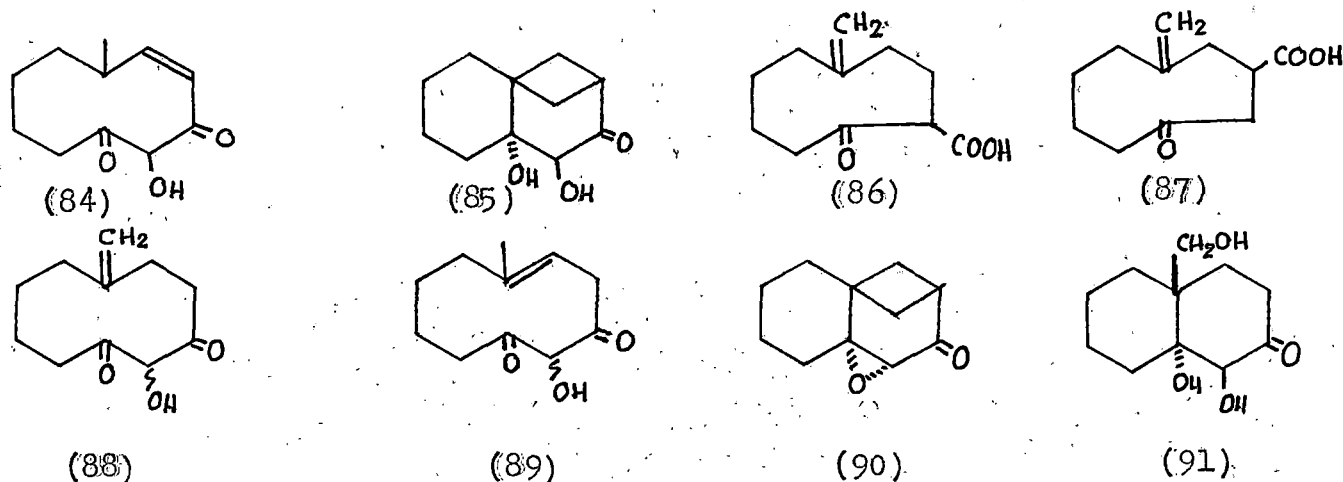

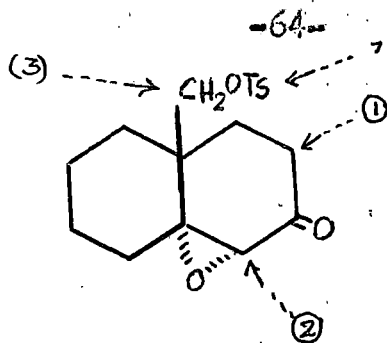

in the formation of the trihydroxy compound (91) by (a) opening of the epoxide ring and (b) nucleophilic displacement of the tosyloxy group. Attack on position (1) can generate the carbanion shown below. The carbanion may attack position (3) to give the dihydroxy tetracyclic compound (90). Obviously the isolated

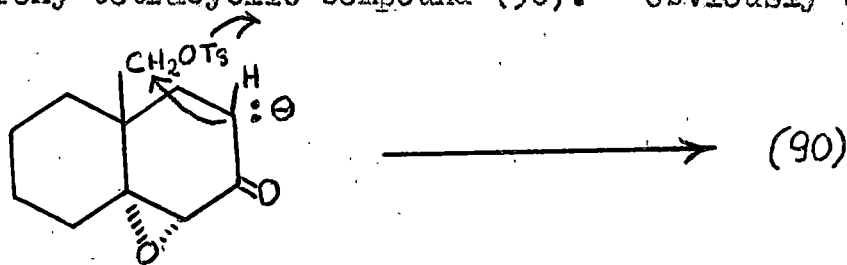

compound is neither (90) nor (91). [ $m/e$  196]. On the other hand the attack by the carbanion on position (2) may release the alkoxide ion which may trigger the rupture of the central bond with the consequent elimination of the tosyloxy group to yield (92).

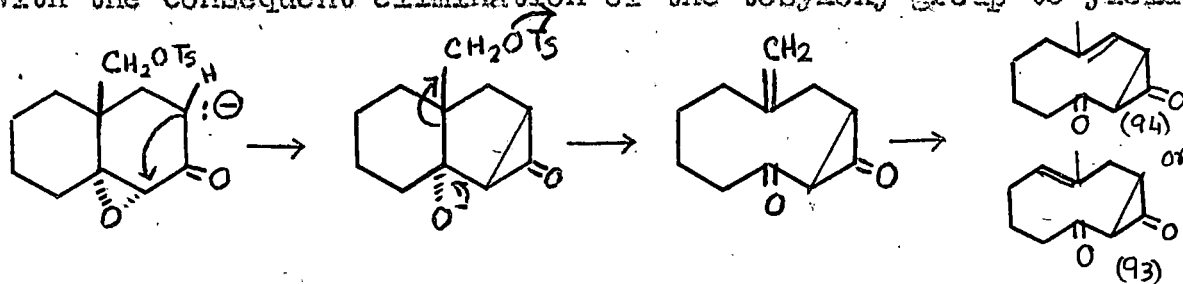

The exo double bond may isomerize to give (93) or (94). The cyclopropane ring of the above compounds may open up to give the acids

(87) and (88) or their endo isomers.

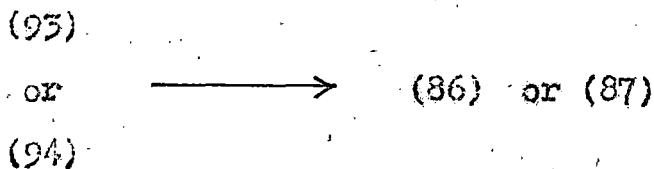

Attack of the base on position (2) may take a different course; the alkoxide release may trigger Eschenmoser - Wharton - Corey fragmentation to give (88) which may rearrange to the endo double-bonded structure (89). This in turn may rearrange to the thermo-

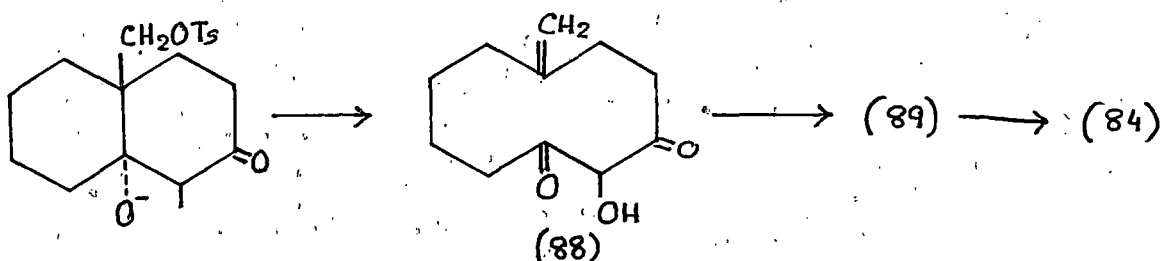

dynamically more stable structure (84).

The method of isolation followed clearly rules out the acids (86) or (87) or their isomers.

The infrared spectrum of the compound showed a broad band at  $3570 - 3550 \text{ cm}^{-1}$  indicating the presence of hydroxy group or groups. The presence of an  $\alpha\beta$  unsaturated carbonyl system is indicated by the strong band at  $1665 \text{ cm}^{-1}$ . There appears to be a hydrogen-bonded carbonyl system. There is no indication of the presence of a free carbonyl group.

The presence of an  $\alpha\beta$ -unsaturated carbonyl group is also indicated in the uv spectrum of the compound. ( $\lambda_{\max}$  236 nm  $\epsilon$  3475 and 281 nm  $\epsilon$  116). However the low extinction coefficient suggests that the compound is not pure. Purification via column chromatography was attempted but this led to rapid polymerisation and was abandoned.

In the pmr spectrum of the compound, the methyl group appeared as a singlet at 1.13 ppm. One would expect the methyl group of (84) to appear as a doublet. The ethylenic protons appear as expected at 5.72 and 6.01 ppm. It appears that the compound is better represented by the structure (95).

This can arise from the initially formed (84). The removal of the vinylogously active proton from C 8 results in the formation of the carbanion (96); the attack of the carbanion on the electrophilic carbon (C<sub>3</sub>) followed by a proton shift will lead to the formation of (95). This type of transannular reactions are very common in medium ring compounds.

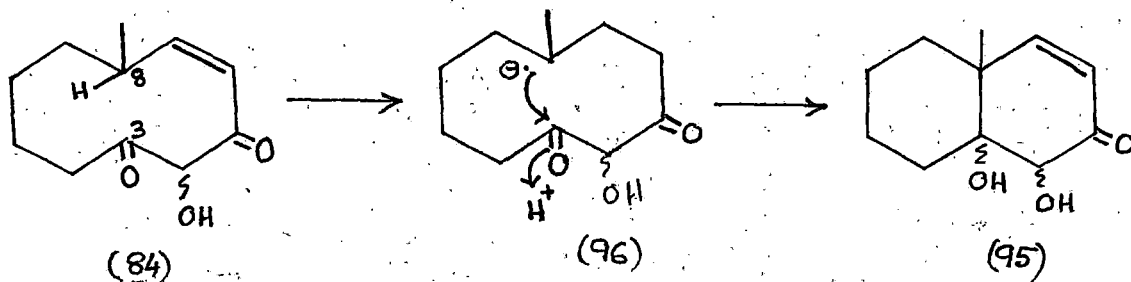

The probable mass fragmentation pattern is indicated below.

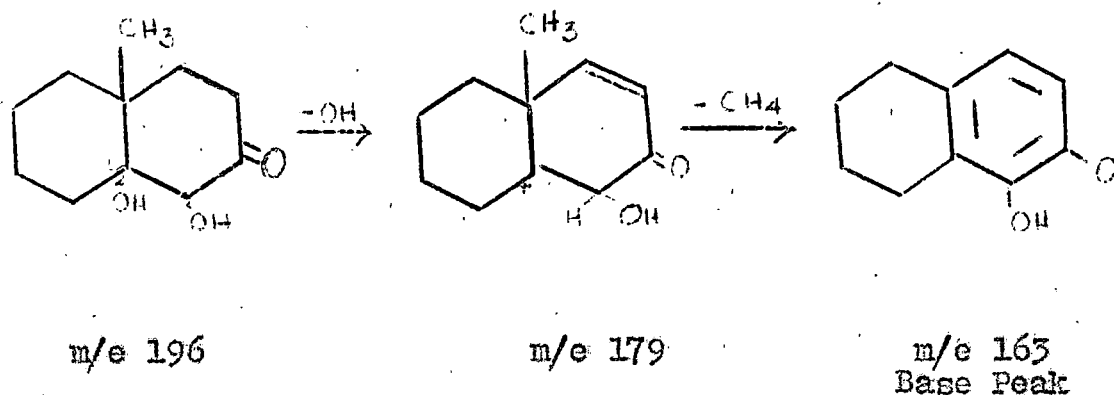

Further work to identify any other rearrangement products is in progress.

Sodio derivative of ethyl cyclohexanone-2-carboxylate (77) was condensed with propargyl bromide to give the acetylenic compound (96) as a major product. Hydration of the acetylenic compound to the diketone (97) [b.p. 135°/1 Torr; disemicarbazone m.p. 216°, Lit<sup>89</sup> 195.5 - 195.6°; ir 1720 cm<sup>-1</sup>, 1695 cm<sup>-1</sup>(broad)] and subsequent ring closure with potassium tert-butoxide gave the unsaturated bicycloketoester (98). [b.p. 132.5/2.8 Torr; semicarbazone 202°, Lit<sup>89</sup> 202.6 - 202.8°; ir 1720 cm<sup>-1</sup>, 1670 cm<sup>-1</sup>]. (98) was converted to the ketal (99) by refluxing with 1.2 equivalent of ethanediol and a catalytic amount of para-toluenesulphonic acid. [b.p. 140°/0.5 Torr], ir 1720 cm<sup>-1</sup>. Reduction of the ketal with Lithium aluminium hydride gave the ketal alcohol (100) [b.p. 145°/0.5 Torr]. Deketalisation



by refluxing with hydrochloric acid in methanol gave the unsaturated ketoalcohol (101). [b.p.  $135^{\circ}/0.5$  Torr; 2,4-dinitrophenylhydrazone, m.p.  $152^{\circ}$ ; ir 3520, 3480 (broad),  $1720\text{ cm}^{-1}$ ] Treatment of (101) with alkaline hydrogen peroxide gave the epoxyketoalcohol (102). [m.p.  $72^{\circ}$ , ir 3480, 3340 (broad),  $1720\text{ cm}^{-1}$ ]. Careful treatment with freshly distilled ~~para~~-toluene sulphonyl chloride in pyridine at  $0^{\circ}\text{C}$  gave the epoxyketotosylate (75) as a gummy mass which did not solidify even after prolonged trituration. [ir crude  $1715\text{ cm}^{-1}$ ]

The compound on treatment with sodium hydroxide at  $0^{\circ}\text{C}$  for three hours gave a mixture of products from which could be isolated a viscous oil, b.p  $135^{\circ}/0.5$  Torr.

From theoretical considerations the compound isolated could have any one of the following structures.

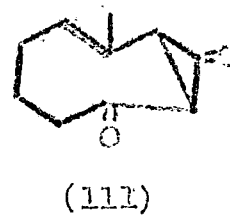
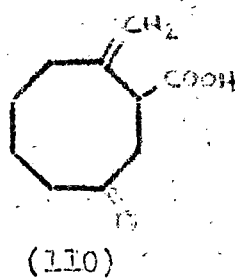
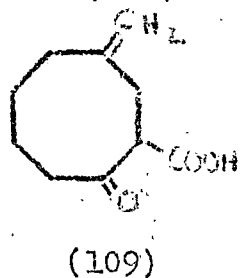
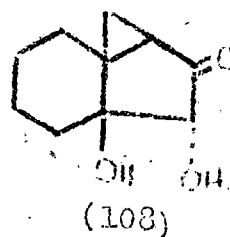
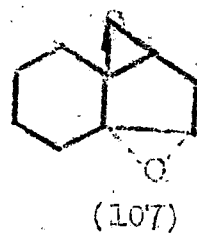
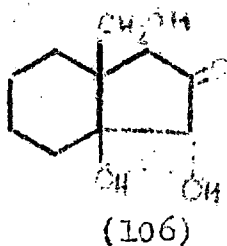
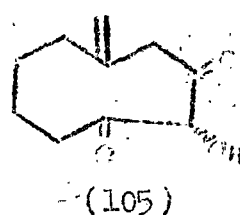
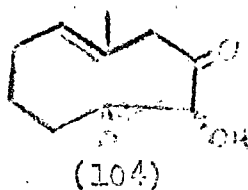
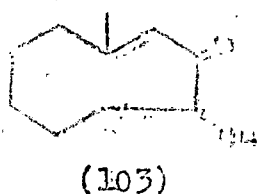

In the infrared spectrum the compound showed bands at 3450, 3360  $\text{cm}^{-1}$  and 1720  $\text{cm}^{-1}$  indicating the presence of a hydroxyl group and a saturated carbonyl groups. The m/e of the compound is 182.

The method of isolation clearly rules out the structures (109) and (110) for the compound. Moreover compounds having the structures are likely to decarboxylate during distillation. Similarly structures (106) and (107) can be rejected on the basis of mass spectrum. Structure (111) also is not compatible with ir and mass spectra.

PMR spectrum indicated the presence of a vinyl methyl group (2.05 ppm, singlet 3H). The signal at 6.75 ppm may be attributed to the olefinic proton at C-4. The absence of any signal at about 4 ppm suggests that the compound is probably present in the enolic form of a diketone. This appears to be a reasonable conclusion in view of the known behaviour of 1,3-diketones. Enols derived from structures (105) and (104) can best account the pmr spectrum of the compound.

However, the infrared spectrum looks anomalous. It is known that  $\alpha, \beta$ -unsaturated medium ring ketones are known to exhibit anomalous ir and UV spectra<sup>38, 39</sup>. The ir spectra of these cyclic ketones showed strong normal carbonyl absorption maxima at 1700 - 1705  $\text{cm}^{-1}$ , low intensity conjugated carbonyl maxima at

1670 - 75  $\text{cm}^{-1}$ , and C C stretching frequency at 1625 - 1630  $\text{cm}^{-1}$  suggesting the preponderance of conformations in which the carbonyl group and the carbon-carbon double bond (presumed to be  $\alpha, \beta$ unsaturated) are not coplanar. The low molecular extinction coefficients of these compounds have also been attributed to this steric resistance to coplanarity. A study of a model of (112) shows that in conformations where the double bonds are in conjugation with the carbonyl group there is a severe over-crowding leading to unfavourable trans annular interactions. We consider, therefore that such a compound is likely to show normal carbonyl absorption in the infrared. We are therefore proposing (112) as a tentative structure for the base treatment product. We however feel that further work is warranted.

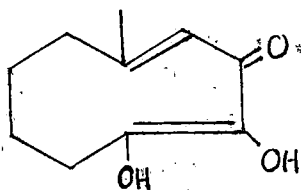

(112)

5,5-dimethylcyclohexane-1,3-dione (113) was prepared from mesityl oxide and diethyl malonate according to the procedure described in literature. Methylation with methyl iodide in presence of sodium methoxide gave 2,5,5-trimethylcyclohexane-1,3-dione (114) in about 60% yield. Condensation with 4-diethylaminobutan-2-one followed by cyclisation of the resulting trione (115) gave 6,6,9-trimethyl-3,8,-dioxo- $\Delta^{4,10}$ -octalin (116). Reduction of the

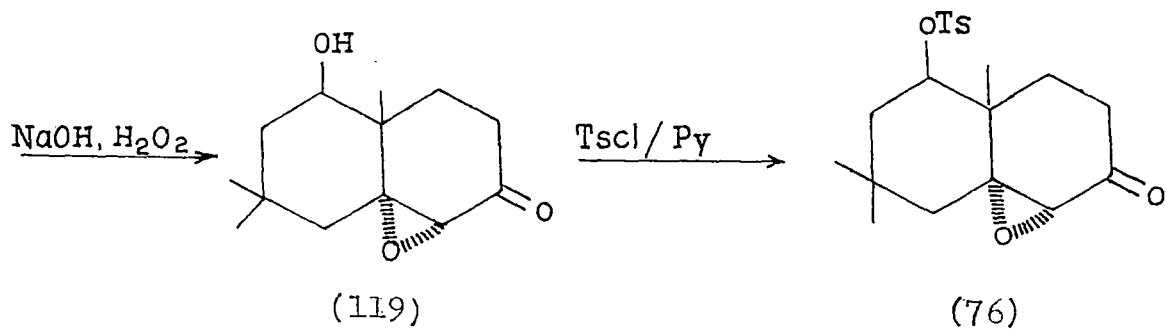
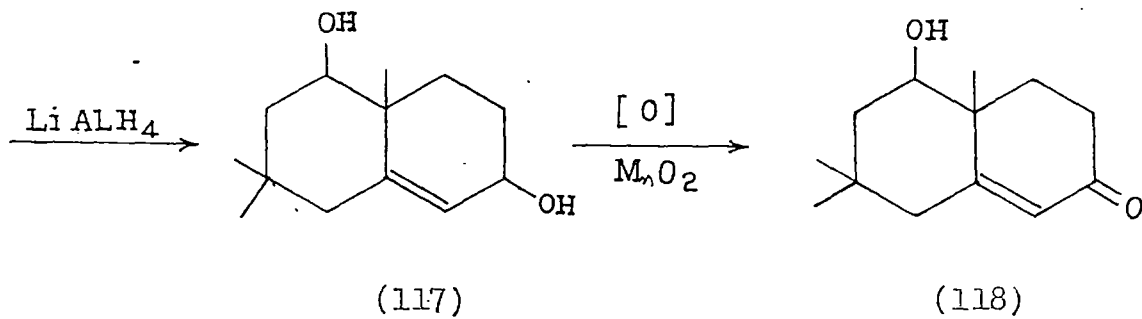
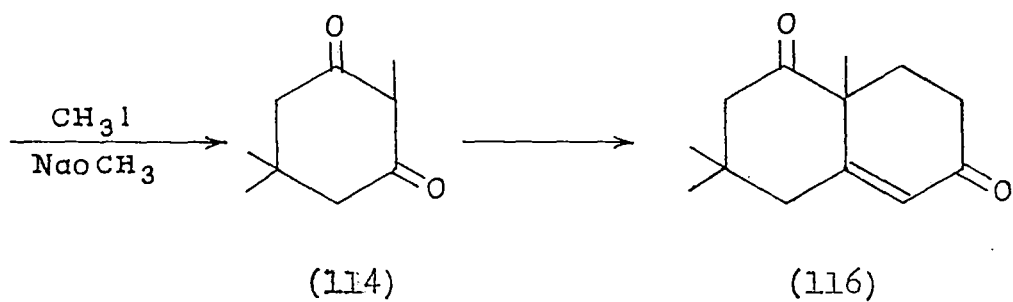
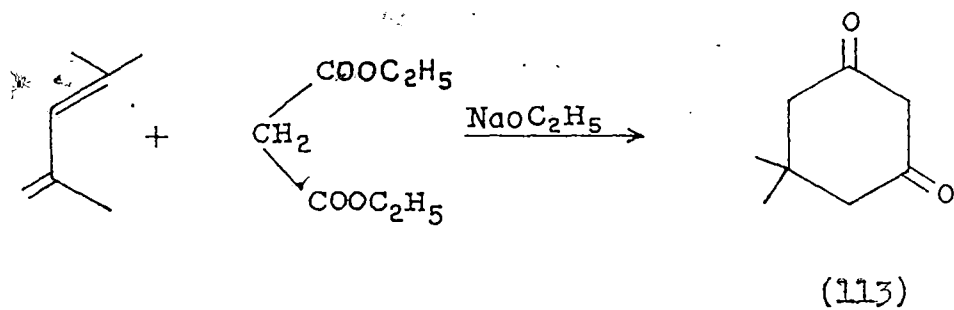

octalin with lithium aluminium hydride furnished 6,6,9-trimethyl- $\Delta^{4,10}$ -octalin-3,8-diol(117) as a solid m.p.  $180^{\circ}$ . Oxidation of the diol with manganese dioxide gave the ketone (118) as a solid m.p.  $121^{\circ}$ . Treatment of (118) with hydrogen peroxide in presence of sodium hydroxide gave the epoxide (119) which was converted into the tosylate (76) without further purification. Treatment of the tosylate with base gave a low boiling liquid which was formed by the loss of the tosyloxy group. (m/e 224)

Theoretically the compound may have any one of the following structures.

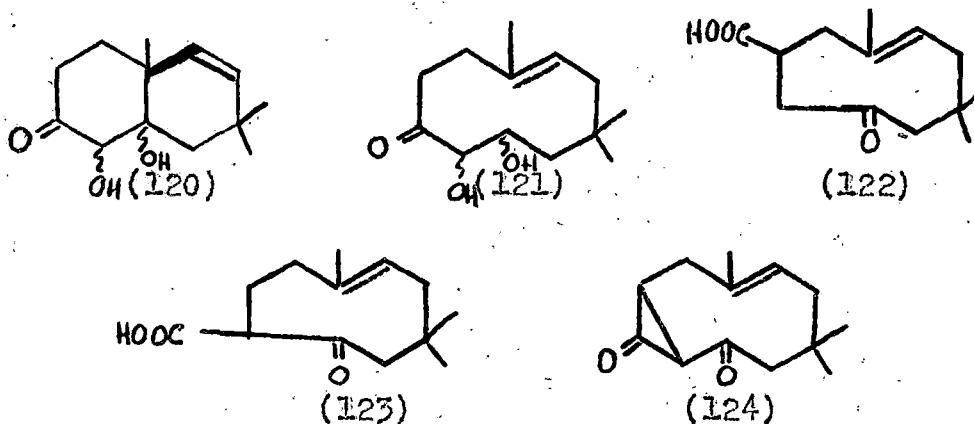

A simple elimination of the tosyloxy group and opening up of the epoxide ring will lead to the formation of (120). Attack by base at the 4-position can generate an alkoxide ion at 10-position (decalin numbering) which can eliminate the tosyloxy group with the scission of the central bond to give the 10-membered ring compound (121). Favorskii rearrangement followed by the rupture of the central bond can lead to the formation

of the acids (122) and (123). An initial formation of the carbocation at C-2 can lead to the formation of (124).

The method of isolation followed rules out the acids as the probable product. (124) can also be rejected on the basis of the mass spectrum. Thus the compound may either be (120) or (121). The compound had a tendency to decompose on standing and with the limited facilities available in our laboratory we are not in a position to assign any definitive structure to the compound. In all probability the compound is a mixture of both (120) and (121).

EXPERIMENTAL

PART I

The melting and boiling points are uncorrected. The solvent extracts were dried over anhydrous sodium sulphate. Alumina used for Chromatographic adsorption was E. Merck (India) grade. Aluminium oxide standardised according to Brockman. Infrared and PMR spectra were recorded on Beckman - 20 IR spectrophotometer and Varian EM-590 90 Mc spectrophotometer, respectively. The symbols 's', 'm', and 'w' represent strong, medium and weak bands in IR.

Ethyl cyclohexanone-2-carboxylate (77):

A solution of sodium ethoxide was prepared by the cautious addition of clean sodium (23g; 1 gm mole) to anhydrous ethanol (200 ml) and cooled to 0° C in an ice-salt bath. A chilled mixture of redistilled cyclohexanone (98g, 1 mole) and diethyl oxalate (146 g, 1 mole) was then added in one lot and after thorough mixing left overnight at 0°. The following day the reaction mixture was diluted, cooled and acidified with 10N sulphuric acid and extracted with ether. The extract was washed until neutral, dried and the solvent distilled off.

To the residue soft glass powder was added and heated in an oil bath at about 130°C until no more carbon monoxide evolved. The residue on distillation gave ethyl cyclohexanone-2-carboxylate (150g) b.p 110°/10 Torr.

Ethyl 2-(3'-oxobutyl)-cyclohexanone-2-carboxylate, (78)

4-Diethylaminobutan-2-one methiodide prepared from methyl iodide (10 ml) and 4-diethylaminobutan-2-one (17g; 0.12 Mole) was covered with anhydrous benzene (100 ml). Ethyl cyclohexanone-2-carboxylate (17g; 0.1 mole) was added in one lot followed by dropwise addition of sodium ethoxide in ethanol [Prepared from sodium (2.5g; 0.1g atom) and anhydrous ethanol (40 ml)] with continuous cooling and stirring. After the addition, the mixture was stirred for an additional hour and left overnight. The following day, the reaction mixture was refluxed for an hour, cooled and diluted. The benzene layer was separated and the aqueous layer extracted with ether once. The combined extracts were washed, dried and concentrated. Distillation of the residue gave ethyl 2-(3'-oxobutyl)-cyclohexan-1-one-2-carboxylate (18g) b.p. 138°/0.5 Torr. It was used as such in the next step.

10-carboethoxy- $\Delta^{1,9}$ -octal-2-one (79)

To a solution of sodium ethoxide in ethanol [prepared from sodium (3.1g, 0.135 g atom) and anhydrous ethanol (160 ml)] was added under an atmosphere of nitrogen ethyl 2-(3'-oxobutyl)-cyclohexan-1-one-2-carboxylate (25g, 0.104 mole) and the reaction

mixture left at room temperature. After 2 hours the mixture was acidified with glacial acetic acid. Sodium acetate was filtered off and alcohol was removed under reduced pressure. The residue was taken up in benzene, washed with brine, saturated sodium bicarbonate solution and again with brine, dried and concentrated. The residue on distillation gave 10-carboethoxy- $\Delta^{1,9}$ -octal-2-one (17g) b.p  $136^{\circ}/8\text{mm}$  IR (liquid, in  $\text{cm}^{-1}$ )  
[Spectrum 1-7 1720 (s), 1670 (s) 1630 (s)]

The 2,4-dinitrophenylhydrazone prepared in the usual way crystallized as crimson plates from ethyl acetate - ethanol. m.p.  $118^{\circ}$  (Lit<sup>88</sup> records 117-118)

Anal. Calcd for  $\text{C}_{19}\text{H}_{22}\text{O}_6\text{N}_4$ , C, 56.71; H, 5.47; N, 13.93%

Found C, 56.70, H, 5.46, N, 13.90%

Semicarbazone prepared in the usual way on crystallization from ethanol melted at  $208^{\circ}\text{C}$

Anal. Calcd. for  $\text{C}_{14}\text{H}_{22}\text{O}_3\text{N}_3$ , C, 66.21; H, 7.52; N, 5.05%

Found C, 66.20, H, 7.50, N, 5.04%

10-Hydroxymethyl- $\Delta^{1,9}$ -octal-2-one (82)

The octalone (79) [22.1 g, 0.1 mole] was refluxed with ethane diol (7.5g, 0.12 mole), para-toluenesulphonic acid (50 mg) and dry benzene (200 ml) using a Dean Stark water separator until no more water separated. The reaction mixture was cooled, washed with saturated sodium bicarbonate solution and brine, dried and

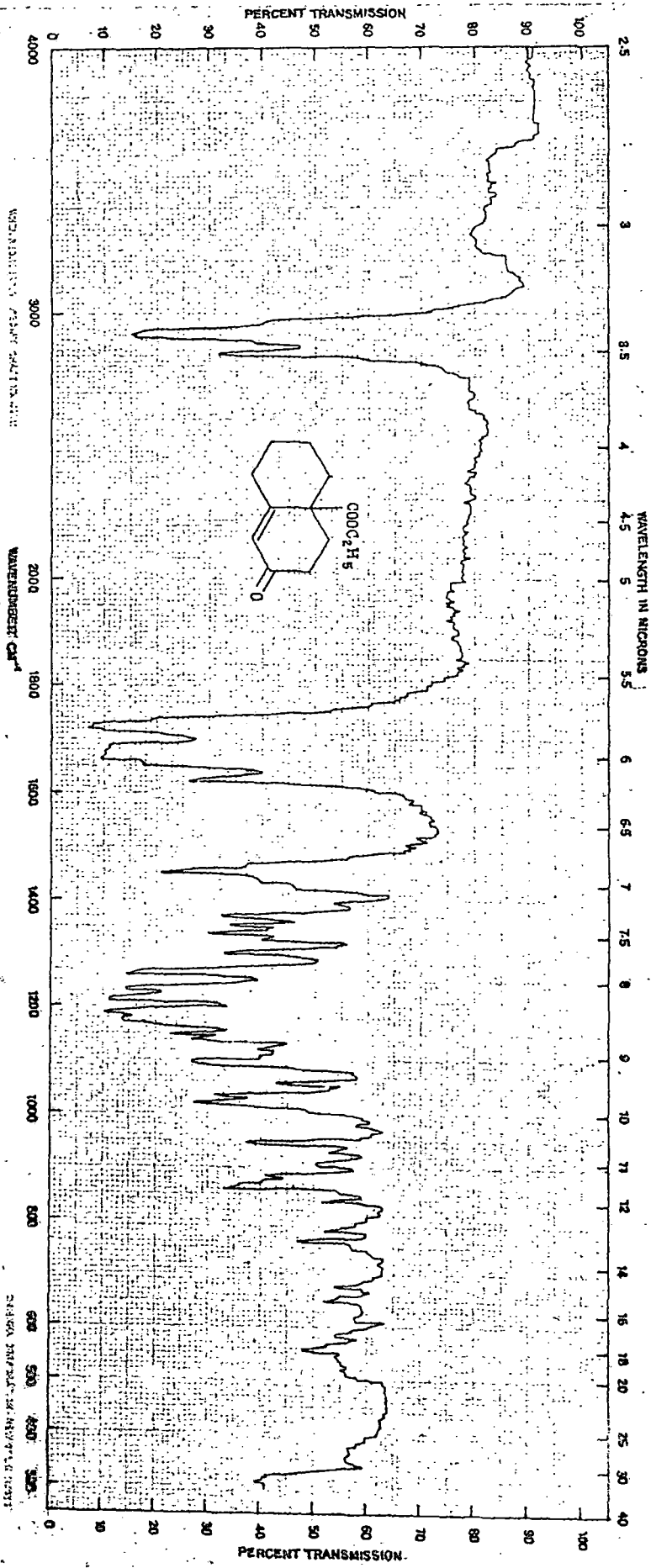

SPECTRUM 1

concentrated. Distillation of the residue afforded the ethylene ketal of 10-carboethoxy-<sup>1,9</sup>octal-2-one (80) 24g b.p. 142°/2 Torr.

I.R. liquid film ( $\text{cm}^{-1}$ ) (Spectrum 2)

1620 (w), 1720 (s)

A solution of the above ketal(80) (28.8g) in dry ether (200ml) was added dropwise with stirring to a solution of lithium aluminium hydride(5.8g) in anhydrous ether (200ml). After the addition was complete the mixture was gently refluxed for 12 hours. The complex was carefully decomposed with a saturated solution of sodium sulphate. The ether layer was separated, dried and concentrated. The residue on distillation gave the ethylene ketal of 10-hydroxymethyl-<sup>1,9</sup>octal-2-one (23g) (81) b.p. 146/1 Torr. m.p. 70°C. I.R (Nujol mull) in  $\text{cm}^{-1}$  (Spectrum 3) 3420, 3380  $\text{cm}^{-1}$

The above ketal (5.7g) was hydrolysed with 65% aqueous methanol (60 ml) containing conc. hydrochloric acid (4 ml) for 1 hour. The product was isolated with ether. The ether extract was washed with brine, saturated sodium bicarbonate solution and water, dried and concentrated. The residue on distillation gave 10-hydroxymethyl-<sup>1,9</sup>octal-2-one (82) b.p 136°/0.6 Torr.

I.R. Liquid film (in  $\text{cm}^{-1}$ ) (Spectrum 4)

3420, 3380 (broad), 1665 (s).

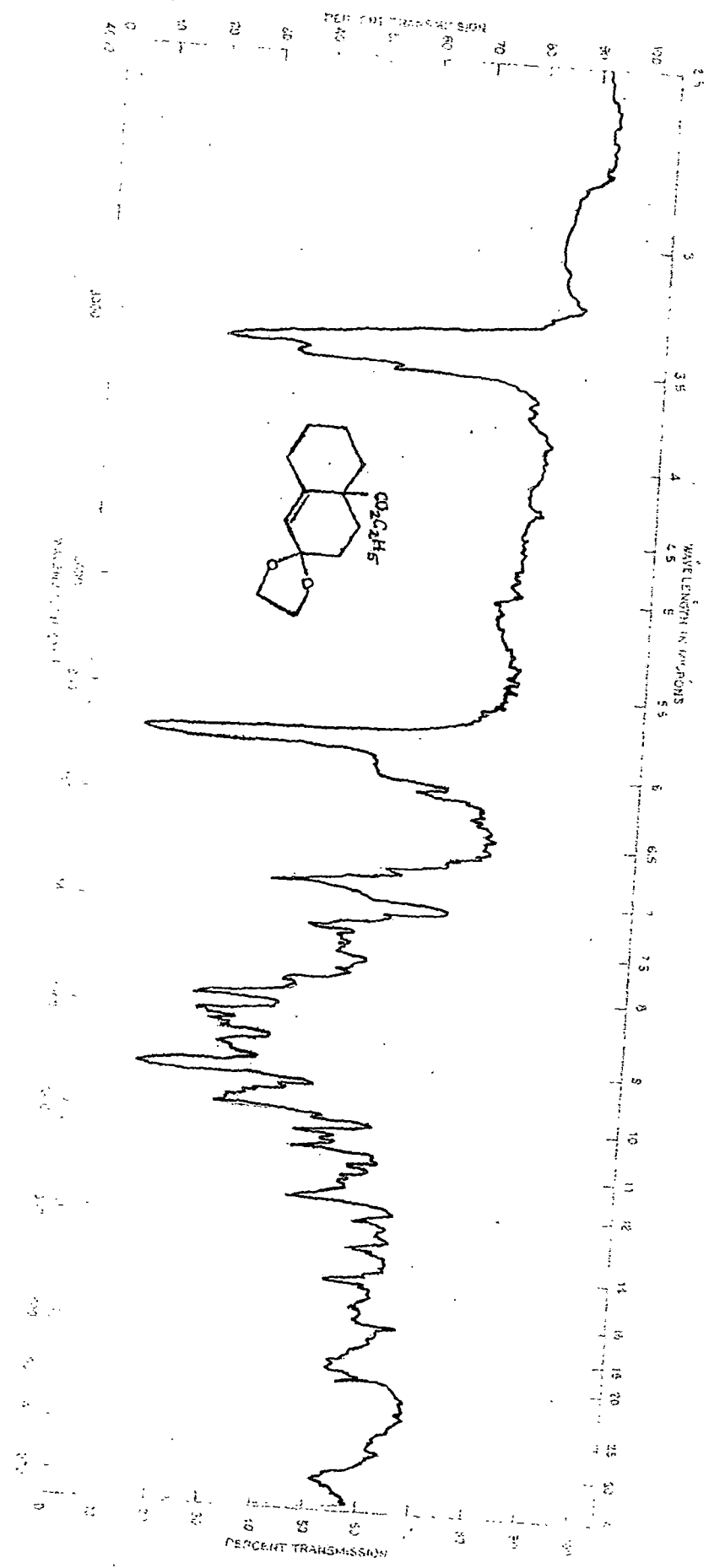

SPECTRUM 2

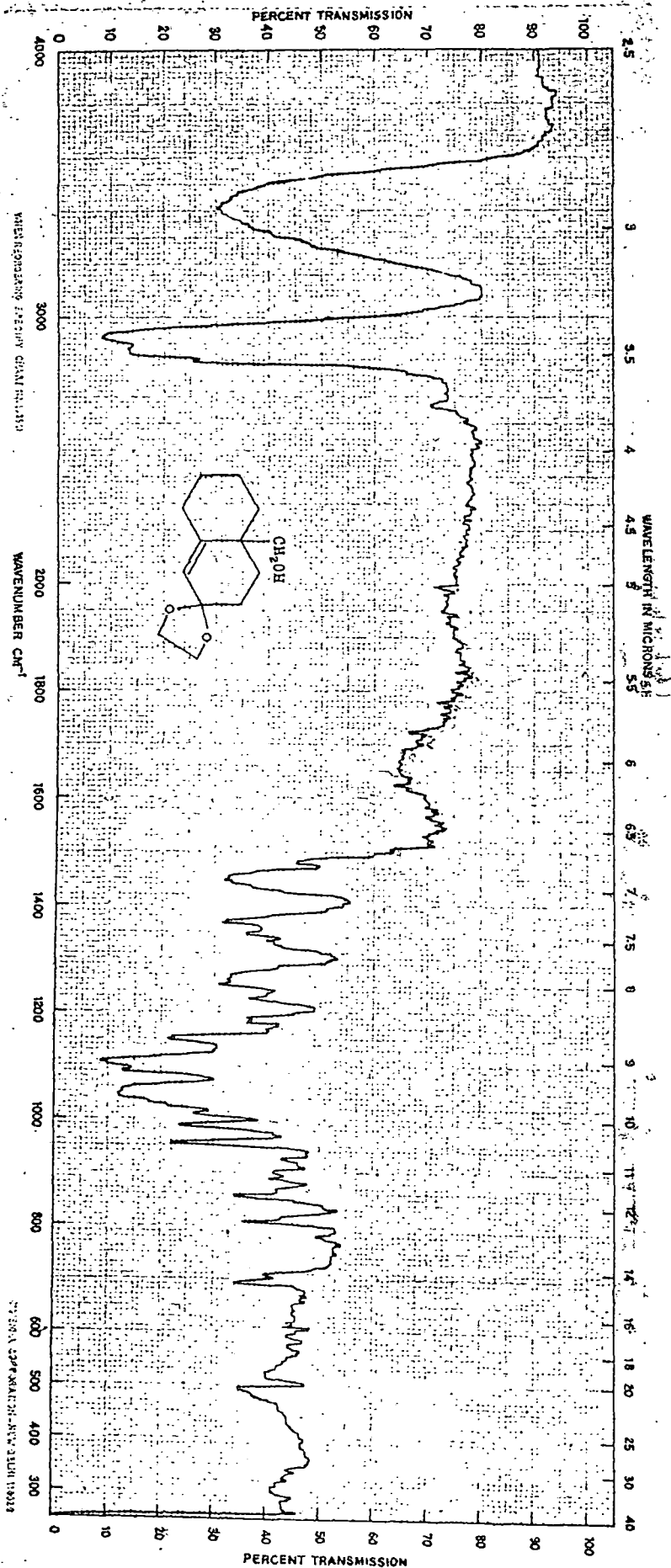

SPECTRUM. 3

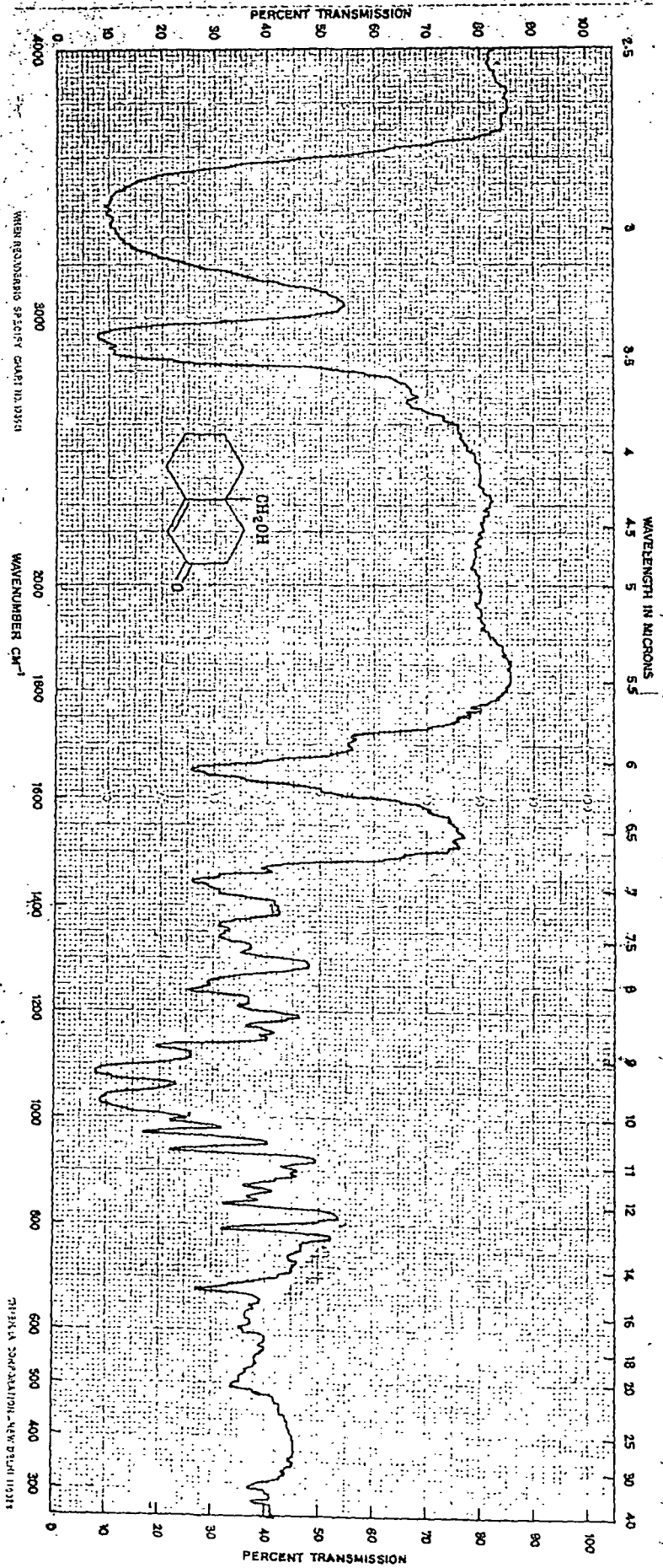

SPECTRUM 4

The 2,4-dinitrophenyl hydrazone of the above compound prepared in the usual way on crystallisation from ethanol had a m.p. 155°C

I.R. (nujol) in  $\text{cm}^{-1}$  (Spectrum 5)

3300 (s), 1610 (s), 1590 (s), 1330 (s)

4-10-Epoxy-9-hydroxymethyl-decan-3-one (83):

A solution of 10-hydroxymethyl- $\Delta^{1,9}$ -octal-2-one (1.7g, 0.01 mole) and methanol (50ml) was cooled to 0°C in an ice-salt bath and a mixture of 4N sodium hydroxide (10 ml) and 30% hydrogen peroxide (10 ml) was added with continuous stirring. After the addition, the reaction mixture was stirred for an additional hour and left at 0°C for 72 hours. After the removal of methanol under reduced pressure, the reaction mixture was diluted with water (30 ml) and extracted with benzene. The solvent extract was washed until neutral, dried and concentrated. The gummy mass on crystallisation from petroleum ether (60-80) gave the epoxy alcohol (83), m.p. 30°C.

Anal. Calcd for  $\text{C}_{11}\text{H}_{15}\text{O}_3$ : C, 67.69; H, 7.69%

Found C, 67.66; H, 7.68%

I.R. (nujol)  $\text{in cm}^{-1}$  (Spectrum - 6)

3480 (s) 1720 (s), 1340 (s), 1370 (s), 1310 (s) 840 (s)

4-10-Epoxy-9-tosylomethyldecan-3-one: (74)

The above epoxy compound (2.0g) was dissolved

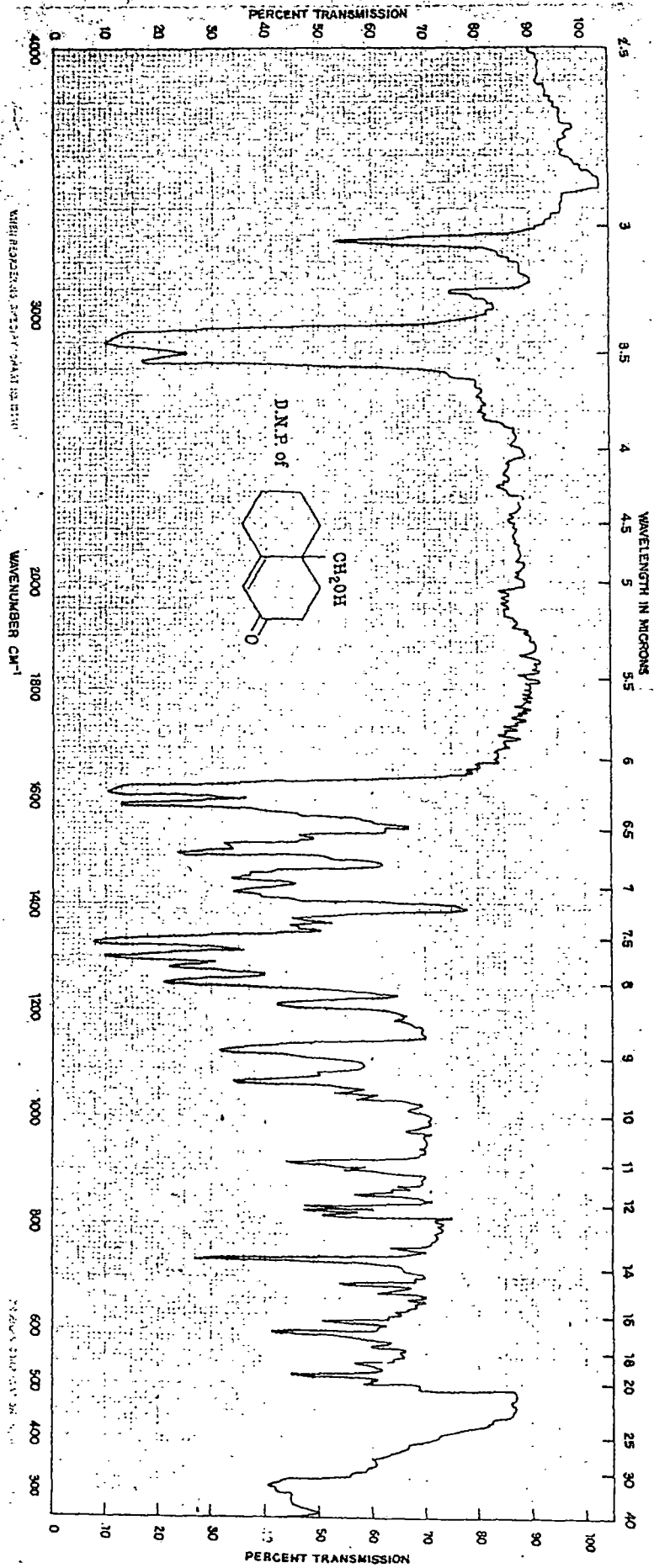

SPECTRUM 5

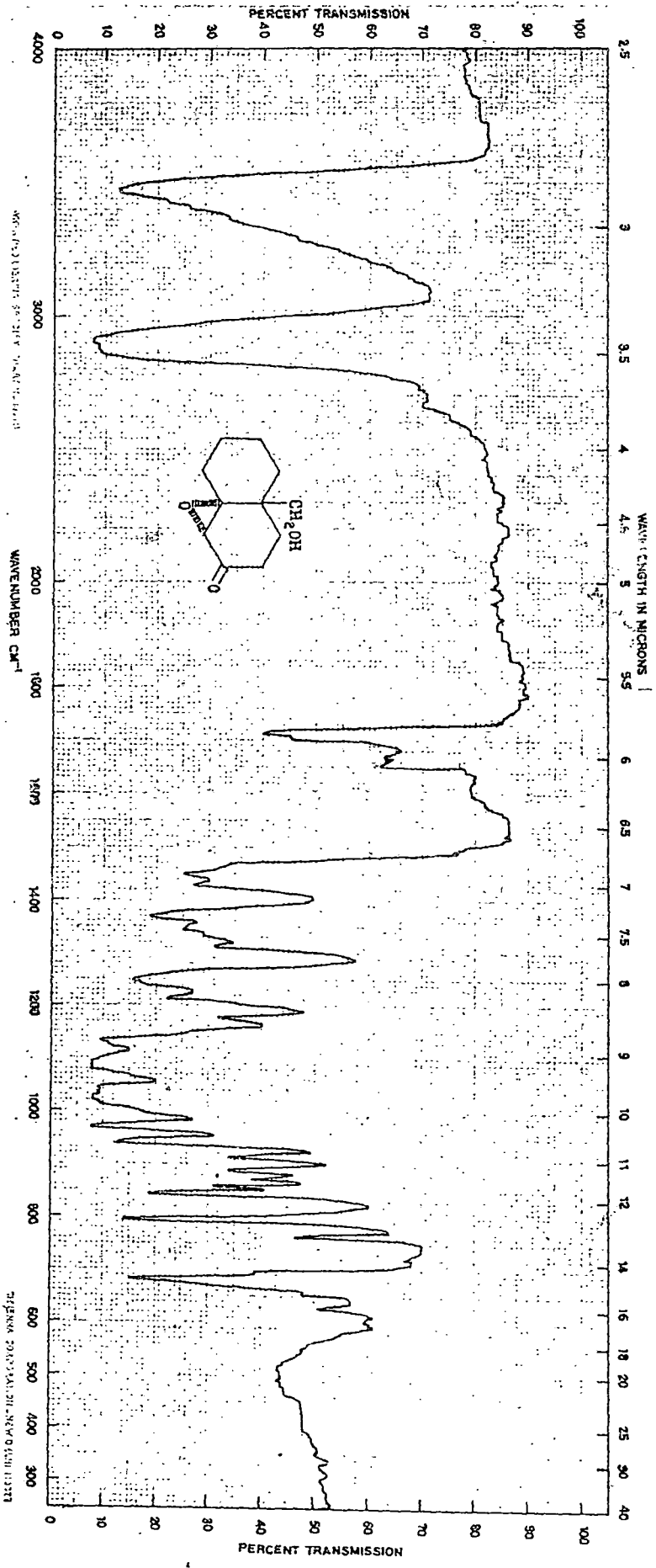

SPECTRUM  $\phi$  6

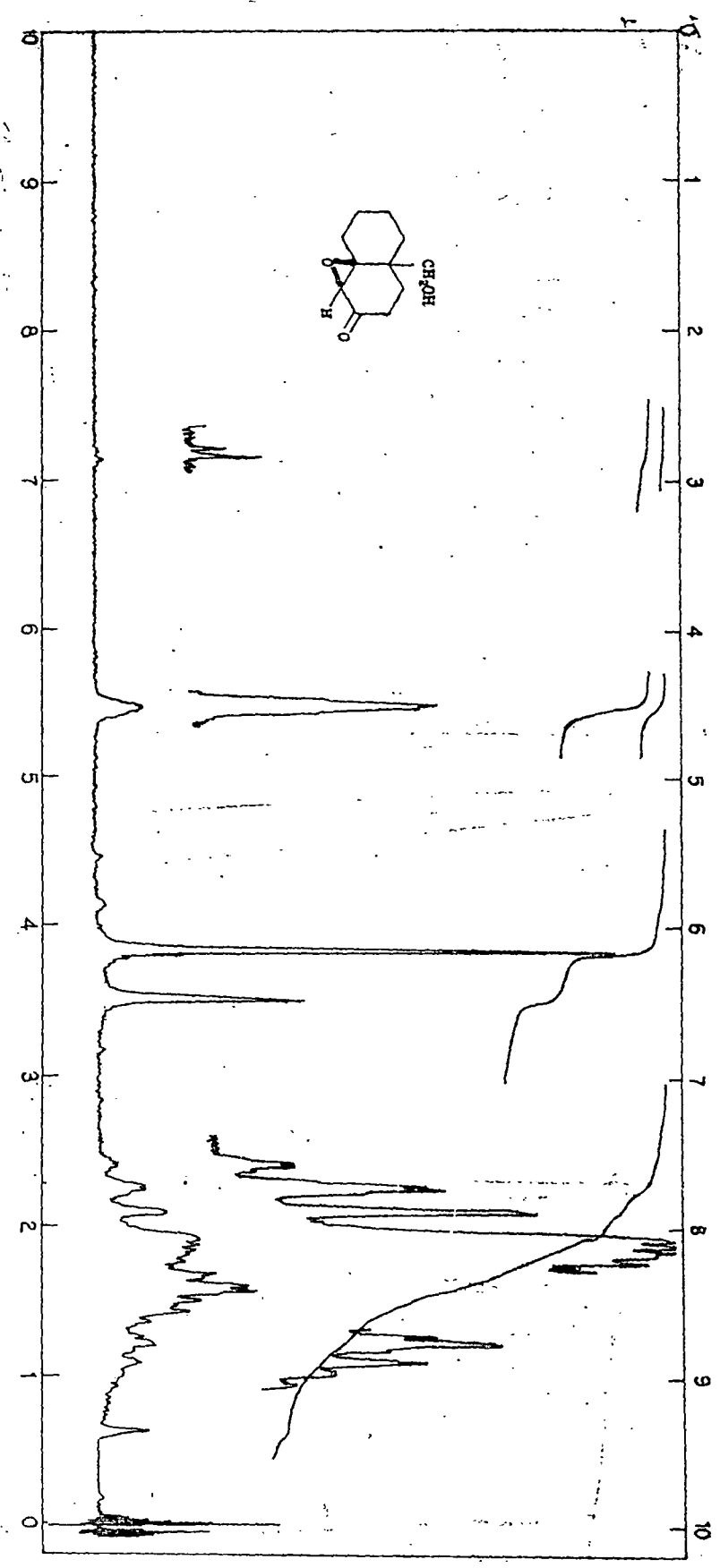

in absolute pyridine (5 ml) and cooled to  $-5^{\circ}\text{C}$ . It was treated with freshly distilled para-toluenesulphonyl chloride (2.5g) in absolute pyridine (4 ml) and left at  $10^{\circ}\text{C}$  for 72 hours. The mixture was poured into a slurry of ice and hydrochloric acid and the white gummy solid extracted with chloroform. The extract was washed with ice-cold water several times, dried and concentrated. The tosylate was obtained as a white solid (5.0 g) m.p.  $98^{\circ}\text{C}$ .

I.R. (nujol)  $\left[ \text{in cm}^{-1} \right]$  (Spectrum 7)

2920(s), 2860 (s), 1720 (s) 1590(m), 1135 (m), 1170(s).

Action of base on (74)

To a solution of 4,10-epoxy-9-tosyloxymethyl-3-decalone (74) (1.0g; .003 mole) in methanol (5 ml) at  $0^{\circ}\text{C}$  was added a methanolic solution of sodium hydroxide (0.5g in 4 ml methanol) in one lot and left at  $0^{\circ}$  for three hours. The reaction mixture was diluted with brine, extracted with ether, washed well with brine and finally with water, dried and the ether distilled off. The viscous liquid on distillation gave (95) b.p  $148^{\circ}/1$  Torr.

I.R. (liquid film)  $\left[ \text{in cm}^{-1} \right]$  (Spectrum 8)

3570, 3350 (broad), 2920(s), 2860 (s), 1700(w), 1665 (s)  
1620 (m), 1460 (s), 1370 (w), 1350 (M), 1260 (s), 1200 (w)  
1165 (m), (865), 810(s), 795 (s)

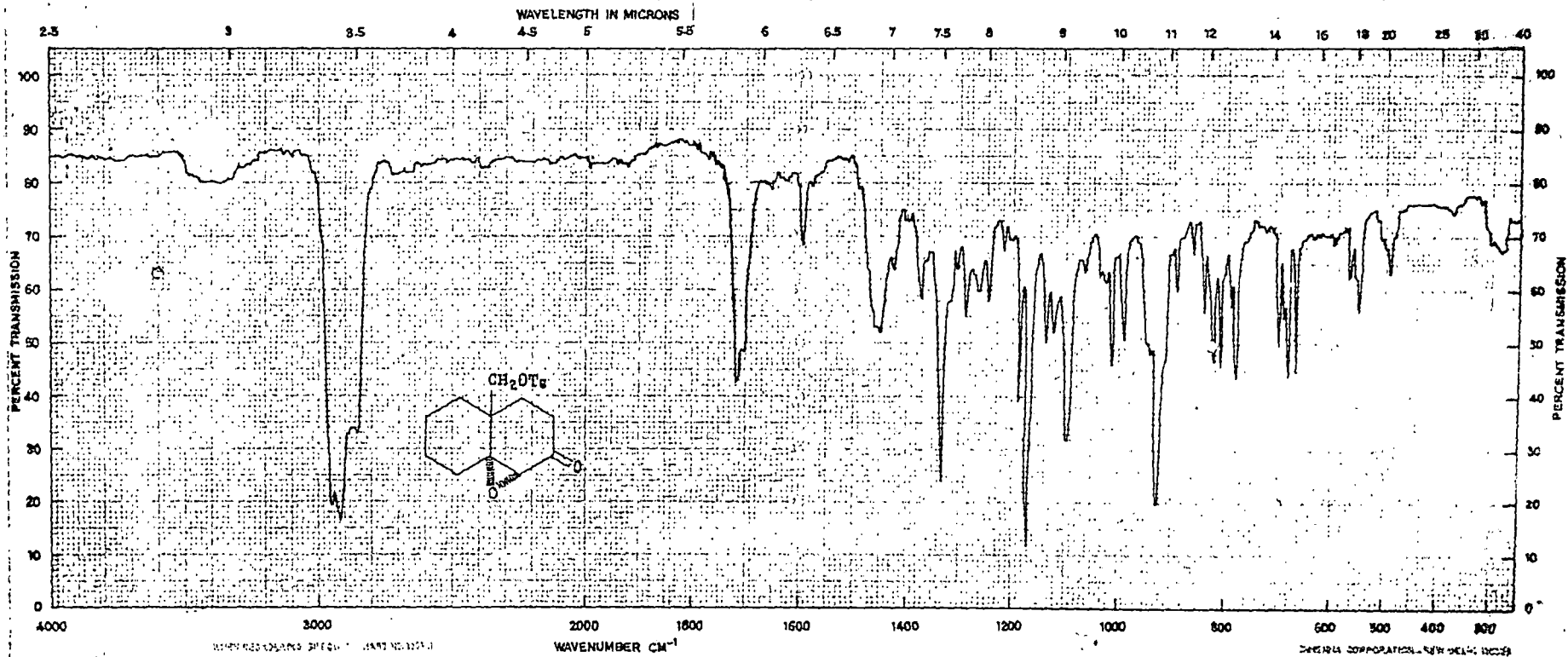

SPECTRUM 7

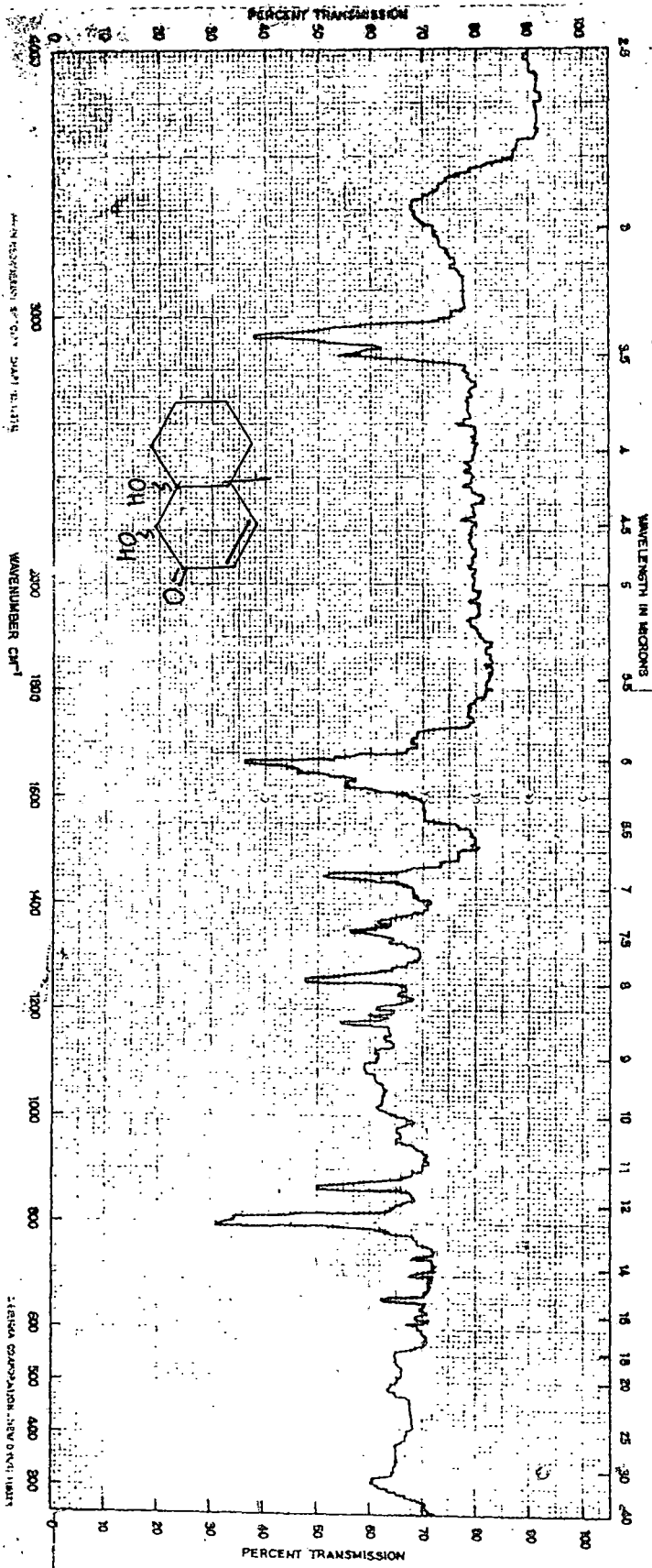

SPECTRUM #8\*

PMR (in ppm) (Spectrum 9)

1.18 (3H, s), 1.41 to 1.99 (6H), 2.29 (2H), 3.99(1 H)  
5.72(1H,S), 6 .01,(1H d)

Mass (Spectrum 10) (m/e)

195, 179, 163 (base peak), 135, 121, 107, 79, 51

The aqueous portion was acidified with dilute hydrochloric acid (1:1) and extracted with chloroform, washed until neutral, dried and conc entrated. The gummy mass which did not solidify could not be purified and was not investi gated further.

Ethyl-2-propargyl-cyclohexan-1-one-2-carboxylate (96)

To the sodio-derivative of ethyl cyclohexanone-2-carboxylate prepared in the usual way from ethyl cyclohexanone-2-carboxylate (51g, 0.3 mole) and sodium dust (7.5g; 0.33 gram) in anhydrous benzene (200 ml) was added dropwise propargyl bromide (39.27g; 0.33 mole) with cooling and stirring. The mixture was refluxed on a steam bath for 5 hours, cooled, washed well with water and concentrated. The residue on distillation gave ethyl 2-propargylcyclohexan-1-one-2-carboxylate (56g) b.p. 136°/9 Torr.

Semicarbazone prepared by sodium acetate method on crystallisation from aqueous ethanol melted at 154°. (Lit<sup>89</sup> records 152.7 = 153.5°  
~~202.4 - 202.2~~)

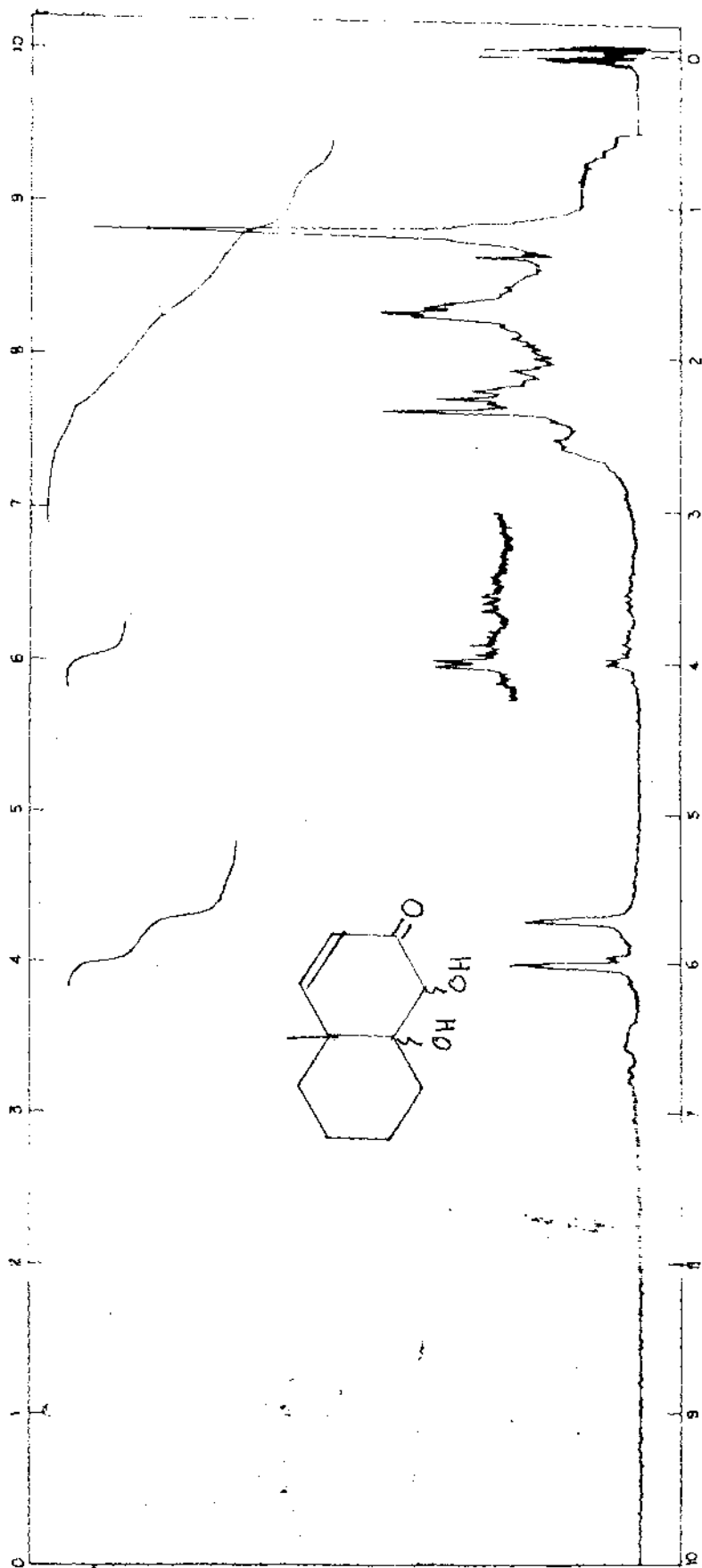

Spectrum 9

SPECTRUM (3 TO 4)  
FILE AM-FR-S-3, DR. A.K. GHOSH, N.W. UNIVERSITY  
DATE : 4TH. AUG. 82  
WAVE PEAK : M/E 163.0 INT. 445.0

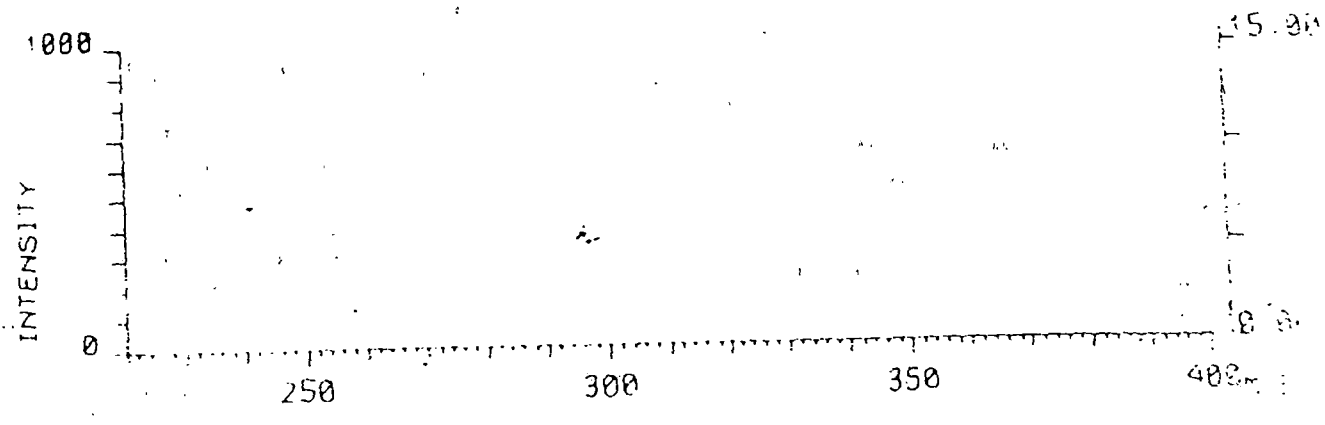
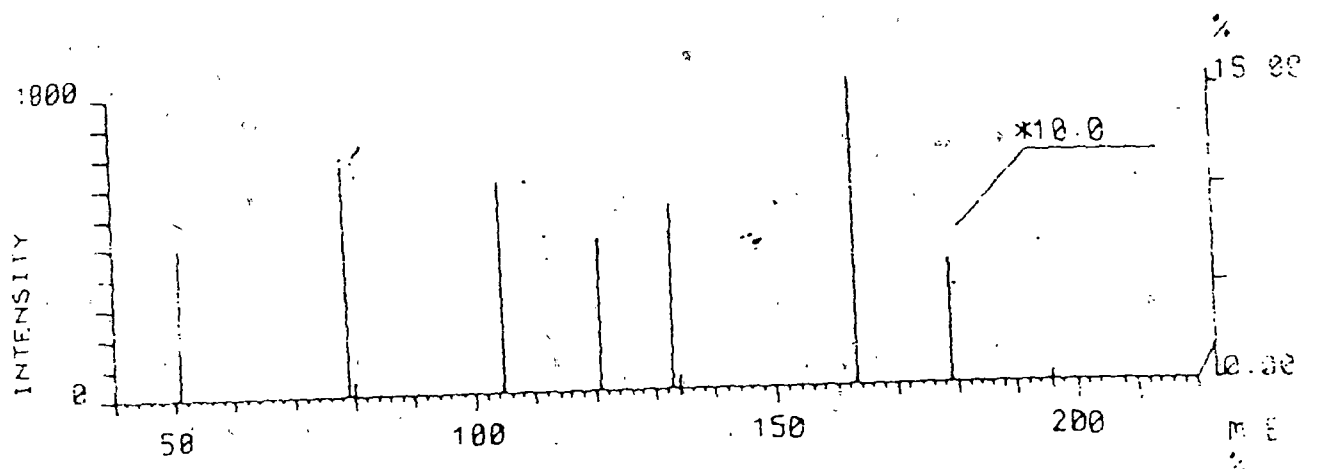

Spectrum 10

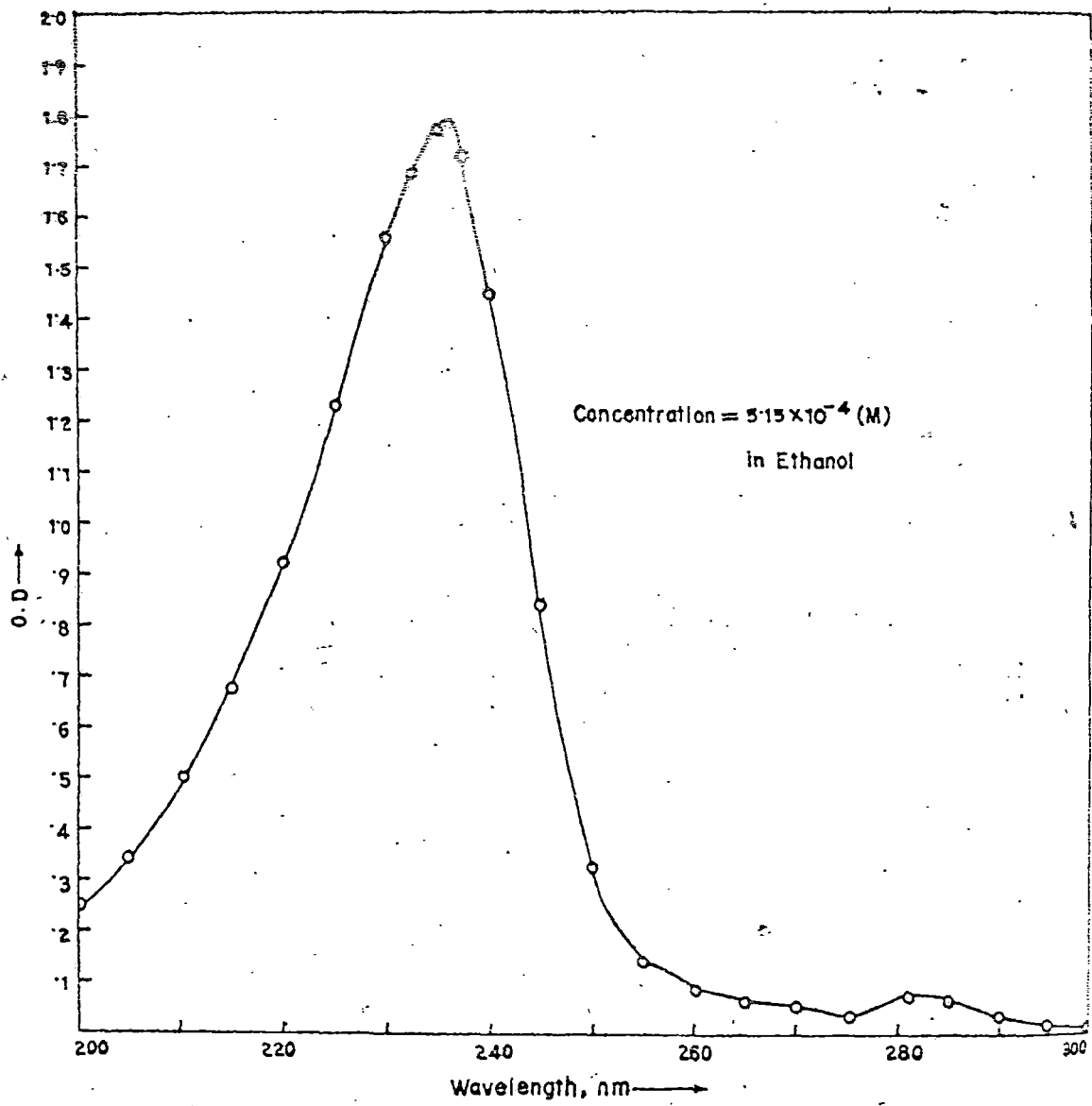

UV Spectrum of (95)

Ethyl 2-(2'-oxopropyl)-cyclohexan-1-one-2-carboxylate (97)

A solution of ethyl 2-propargylcyclohexan-1-one-2-carboxylate (58.0g; 0.27 mole) in 100 ml methanol was added dropwise with stirring to the catalyst prepared by momentarily warming a mixture of red oxide of mercury (5.8g), boron-trifluoride - ether complex (3ml), trichloroacetic acid and methanol (15 ml). A slightly exothermic reaction ensued. After the addition the reaction mixture was stirred at room temperature for an additional two hours and poured into very dilute cold sulphuric acid with stirring. The product was isolated with ether, washed with water, dried and the solvent distilled off. The residue on distillation gave ethyl 2-(2'-oxopropyl)-cyclohexan-1-one-2-carboxylate (45g) b.p 135/1 Torr.

I.R (nujol)  $\left[ \text{in cm}^{-1} \right]$  (Spectrum 11)

2940(s), 1720, 1695 (broad), 1360 (s), 1220 (s)

1195 (s), 1155 (s) 1125 (s).

Disemicarbazone prepared in the usual way had a m.p. 216°C. It could not be purified due to its insolubility. (Lit<sup>89</sup> records 195.5-195.6°C, 214°C<sup>90</sup>)

Ethyl 2,4,5,6,7,8-hexahydroindane-2-one-8-carboxylate (98)

Potassium (11.0g; 0.282 g atom) was dissolved in tertiary butanol (450 ml) by heating under reflux. When the solution had cooled to room temperature

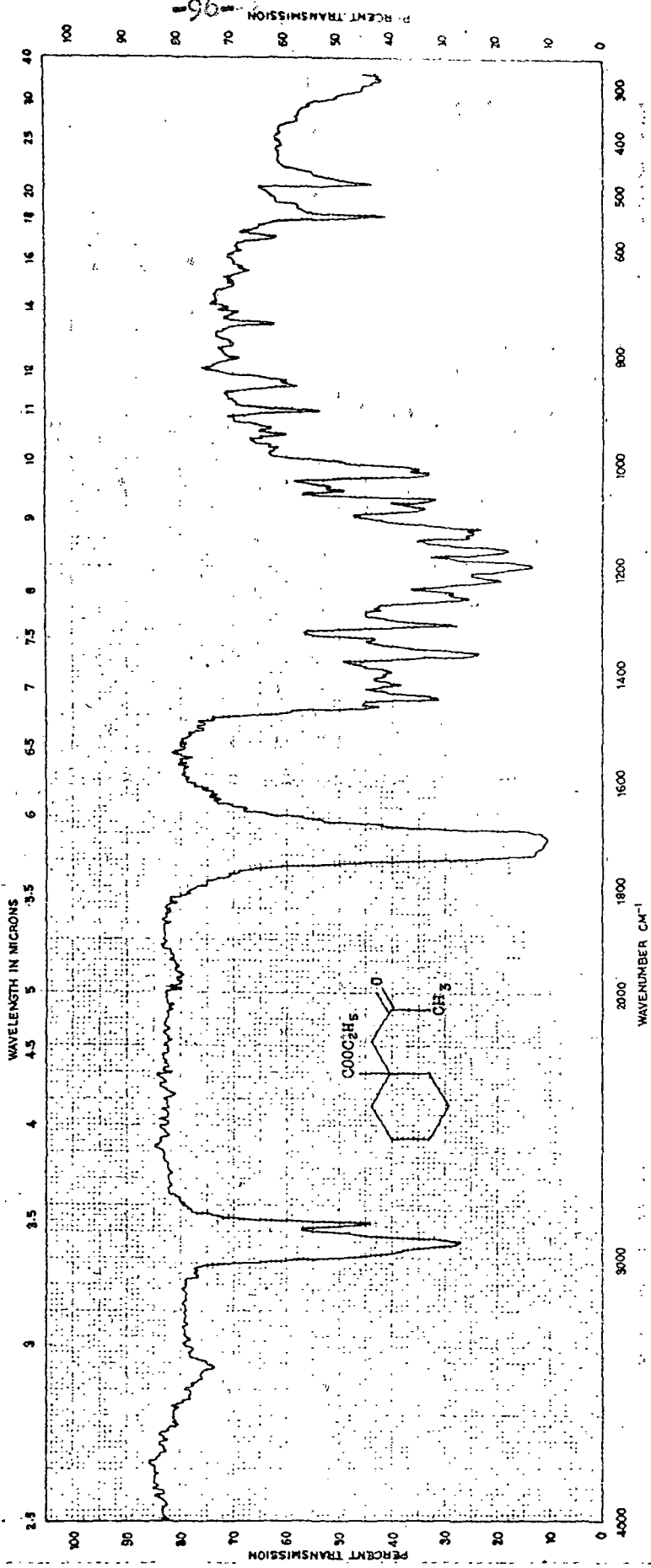

S PECTRUM 11

the reaction mixture was poured into ice water and 24ml of conc hydrochloric acid was rapidly added. The product was isolated after saturating the reaction mixture with sodium chloride by extraction with ether. The solvent extracted was washed with water, dried and concentrated. The residue on distillation gave ethyl 2,4,5,6,7,8-hexahydroinden-2-one-3-carboxylate (97) 20g, b.p.  $132.5^{\circ}\text{C}/2.8$  Torr  
I.R (liquid film)  $[\text{in cm}^{-1}]$  (Spectrum 12)  
2920(s), 2840 (s), 1720 (s), 1670 (s), 1370 (m), 1340 (w)  
1220 (s), 1190 (m), 1150 (m)

Semicarbazone prepared in the usual way on crystallisation from ethanol melted at  $202^{\circ}$  (Lit<sup>89</sup> records  $202.6-202.8^{\circ}$ ).

Anal. Calcd for  $\text{C}_{13}\text{H}_{19}\text{O}_3\text{N}_3$ : C, 58.86; H, 7.16, N, 15.85%  
Found C, 58.84; H, 7.15; N, 15.83%

Ethylene ketal of 3-hydroxymethyl-2,4,5,6,7,8-hexahydroinden-2-one (100)

A mixture of the ketoester (98) (20.8g; 0.1 mole) ethane-diol (8.16g; 0.15 mole), para-toluenesulphonic acid (50 mg) and dry benzene (200 ml) was refluxed using a water separator for three hours after which time no more water separated. The reaction mixture was cooled, washed with saturated sodium bicarbonate solution and water and concentrated. The residue on distillation gave 28 g of the ethylene ketal of (98). b.p.  $140^{\circ}\text{C}/5$  Torr.

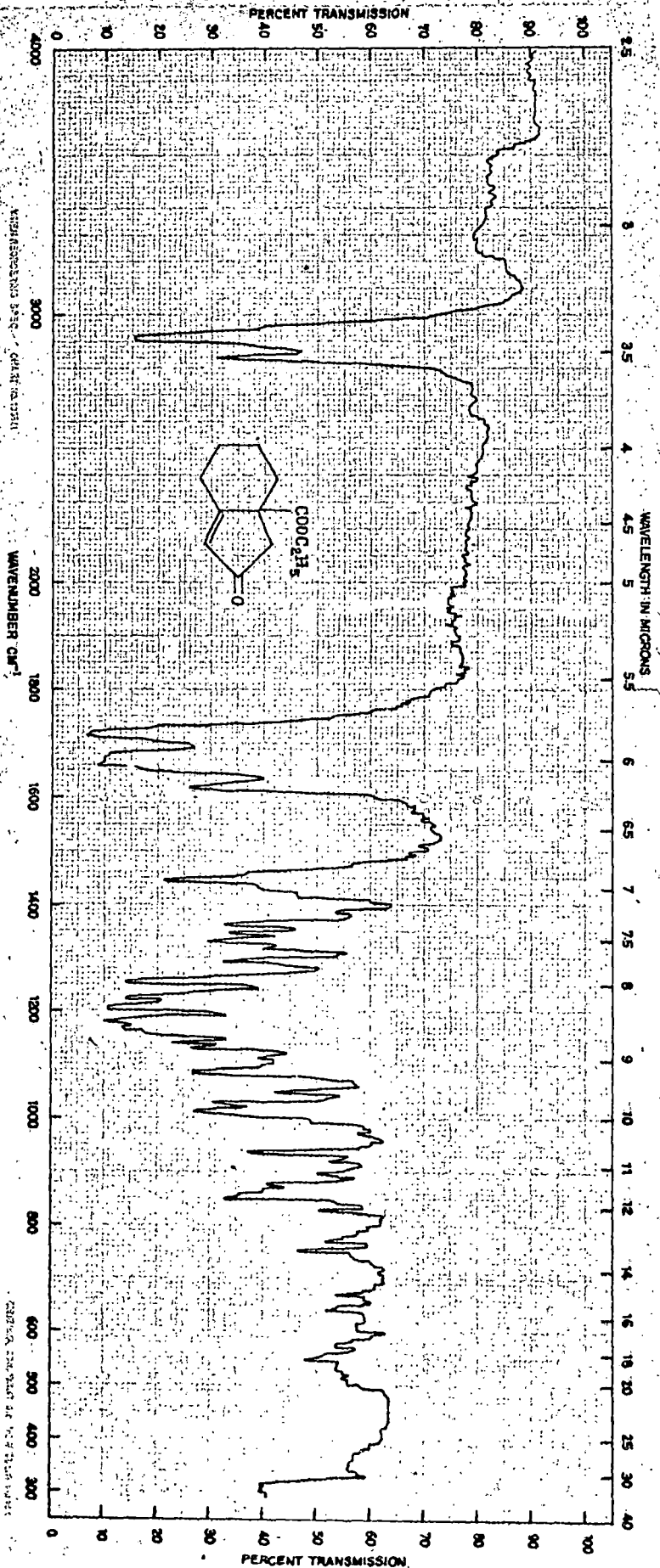

SPECTRUM 12

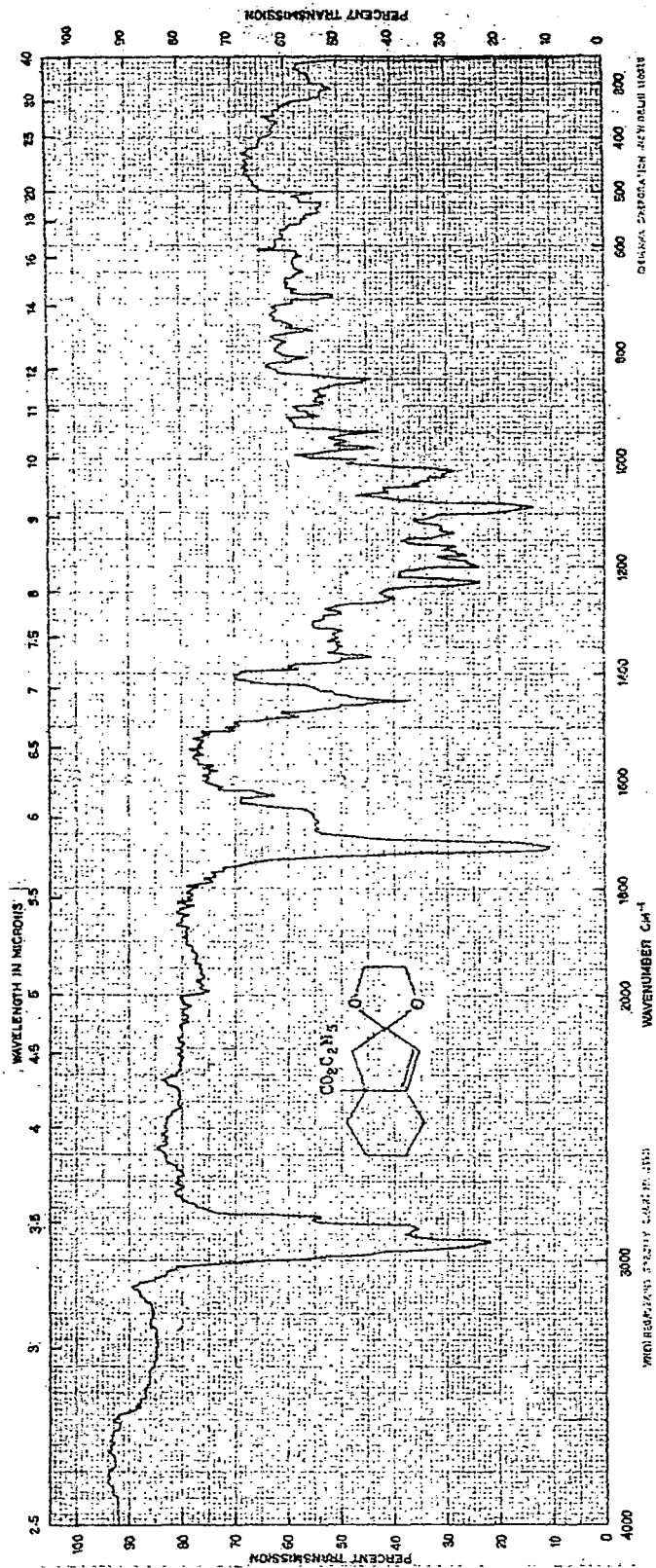

SPECTRUM 13

I.R (liquid film)  $\left[ \text{in cm}^{-1} \right]$  (Spectrum 13)

2920 (s), 1720 (s), 1620 (w), 1450 (s), 1370 (m)  
1350 (w), 1260 (m), 1230 (m)

The solution of the above ketal in anhydrous ether (100 ml) was added dropwise with stirring to a solution of lithium aluminium hydride (3.66g) in anhydrous ether (200ml).

After the addition, the mixture was gently refluxed for 12 hours. Excess of the hydride was decomposed with careful addition of water (2 ml) to the well-cooled reaction mixture and the complex was decomposed with sodium sulphate solution. Ether layer was separated, dried and concentrated. The residue on distillation gave the ethylene ketal (100) of 8-hydroxymethyl-2,4,6,7,8-hexahydroinden-2-one (18g), b.p.  $145^{\circ}/0.5$  Torr.

8-Hydroxymethyl-2,4,5,6,7,8-hexahydroinden-2-one (101)

A solution of the ketal (100) (5g) in methanol (30ml) was warmed with 5% hydrochloric acid at  $50^{\circ}$  for one hour; when the turbid reaction mixture became clear, the heating was stopped and the reaction mixture cooled, diluted with brine, extracted with ether and the extract washed well with brine and concentrated. Distillation of the residue gave 8-hydroxymethyl-2,4,5,6,7,8-hexahydroinden-2-one (2.5g) (101)

I.R. (liquid film)  $\left[ \text{in cm}^{-1} \right]$  (Spectrum 14)

3520, 3480 (broad), 2900(s), 1670 (s), 1610 (m), 1440 (s)  
1410(w), 1290 (m), 1230 (w), 1190 (m), 1160(m), 1080,

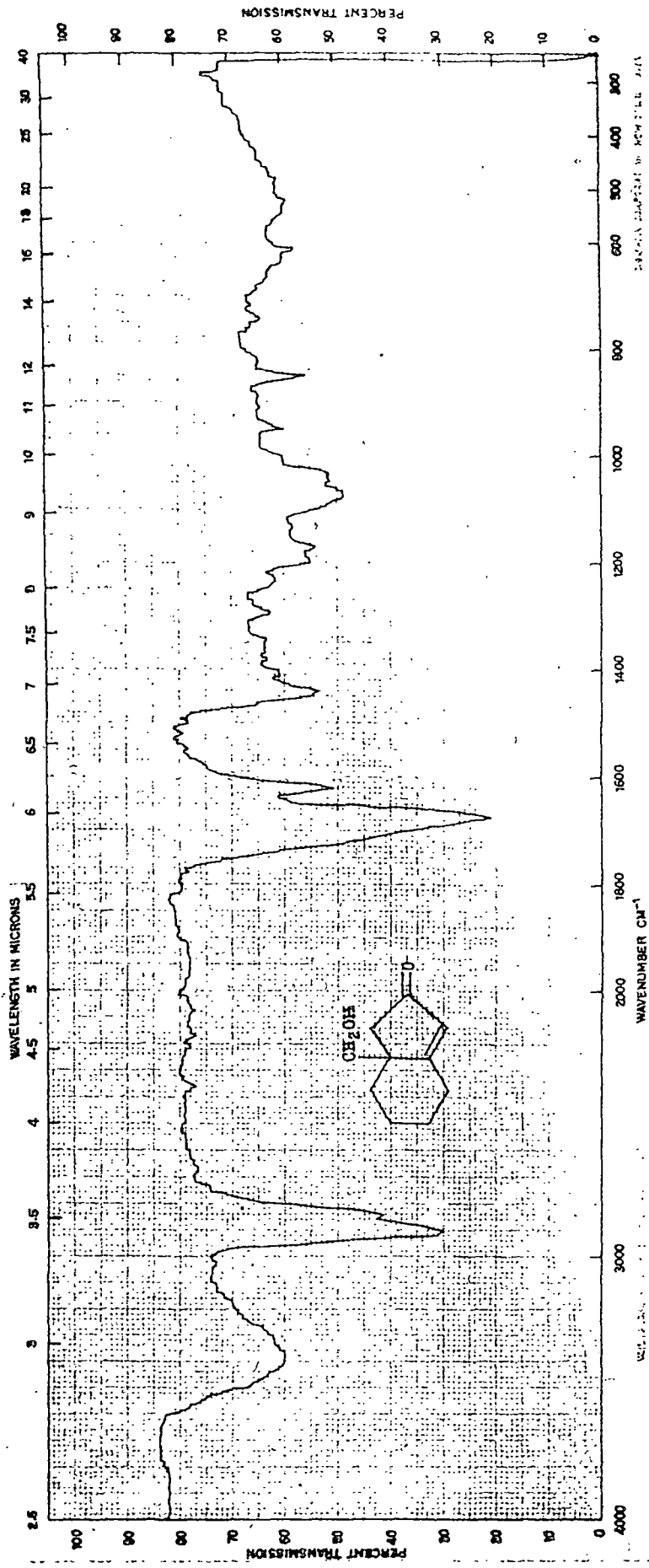

Spectrum 14

1055 (m), 1025 (m), 940 (m), 840 (w), 850 (m), 750 (w)

2,4-Dinitrophenylhydrazone prepared by sulphuric acid method on crystallisation from dilute ethanol separated as red crystals m.p. 152°

Anal. Calcd for  $C_{16}H_{18}O_5N_4$  : C, 55.65; H, 4.92%

N, 16.23%

Found : C, 55.62; H, 4.91, N, 16.21%

I.R. (nujol)  $\left[ \text{in cm}^{-1} \right]$  Spectrum 15

3300 (s), 3100(s), 2920 (s), 2860(s), 1610(s), 1585 (s)

1540(w), 1500(m), 1460(m), 1430(w), 1410(w), 1380(m),

1360(m), 1340(s), 1310(s), 1275(m), 1220 (m), 1190(w)

1130(m), 1065(m), 1040 (w), 920(m), 830 (w)

3,9-Epoxy-8-hydroxymethyl-perhydroinden-2-one (102)

To a solution of 8-hydroxymethyl-2,4,5,6,7,8-hexahydro-inden-2-one (101) (1.66g; 0.01 mole) in methanol (50ml) cooled to 0°C was added a mixture of 4N sodium hydroxide (10ml) and hydrogen peroxide (30%, 10ml) in one lot and the reaction mixture was stirred for one hour and left at 0°C for 72 hours. Methanol was removed at reduced pressure and the residue diluted with water (50ml). The compound was extracted with benzene, washed until neutral, dried and the solvent distilled off. The gummy was crystallised from petroleum ether-ether to give the epoxy-alcohol (102) m.p. 72°

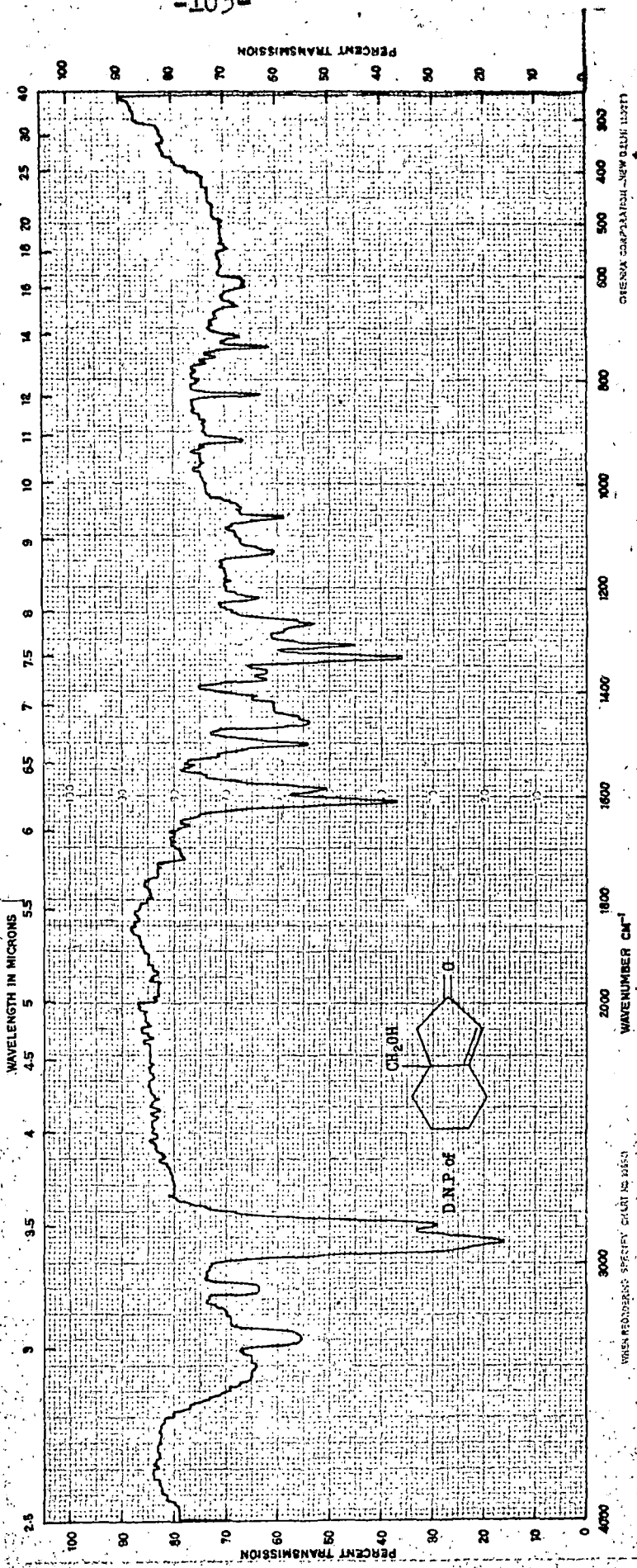

SPECTRUM 15

Anal. Calcd. for  $C_{10}H_{14}O_3$ : C, 65.93; H, 7.69%

Found: C, 65.90; H, 7.68%

I.R. (nujol)  $\bar{\nu}$  in  $cm^{-1}$  ] Spectrum 16.

3420, 3340(broad), 2910 (s), 2840(s), 1720(s)  
1470 (s), 1450(s), 1410(w), 1380(m), 1290(m), 1240(m)  
1210(w), 1190(m), 1140(m), 1090, 1060(broad), 1030(m)  
1010(m), 970 (w), 850 (m), 810 (w), 790 (w)

3,9-Epoxy-8-tosyloxymethyl-perhydroinden-2-one (75)

To a solution of the epoxyalcohol (102) (3.52g; 0.02 mole) in absolute pyridine (5 ml) cooled to  $-10^{\circ}C$  was added a solution of para-toluenesulphonyl chloride (4.5g; 0.21 mole) in absolute pyridine (5 ml) in one lot and left at  $5^{\circ}C$  for 48 hours. The reaction mixture was poured into a slurry of ice and hydrochloric acid and extracted with chloroform. The extract was washed thoroughly with water, dried and concentrated. The crude gummy tosylate which could not be solidified was used as such in the next step.  
Yield (crude) (4.5g)

I.R. (gummy mass)  $\bar{\nu}$  in  $cm^{-1}$  ] (Spectrum 17)

2920, 2840 (broad), 2670 (w), 1715 (s), 1660(m), 1620(w)  
1590(s), 1470(s), 1440(s), 1420(s), 1390(w), 1370(s)  
1325 (s), 1280(m), 1260(w), 1240(m), 1205 (m), 1180(s)  
1160(s), 1130(w), 1110(w), 1080(m), 1020(m), 1010(m)  
980(s), 940, 900 (broad), 860(s), 840(m), 830(m), 810(m)  
780(m), 700(s)

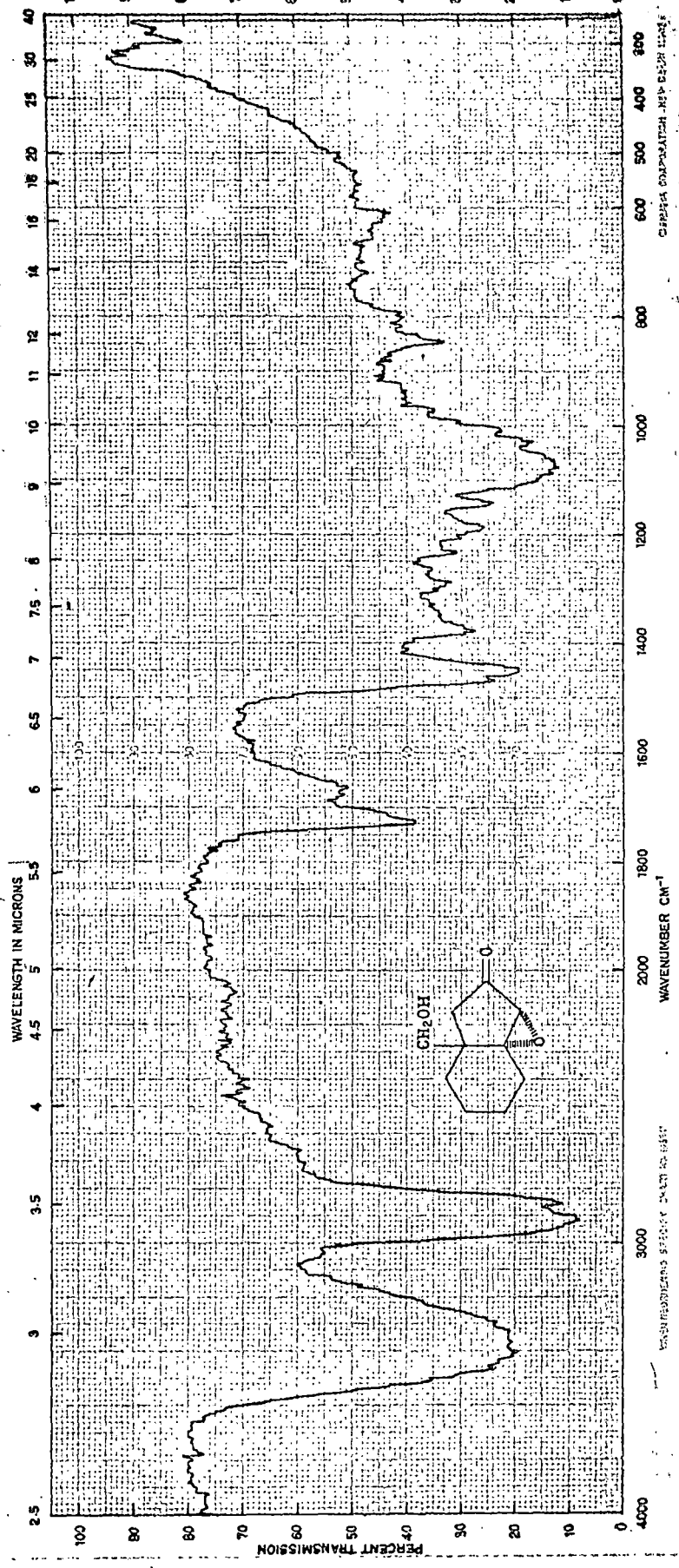

CHEMICAL CORPORATION NEW BRUNSWICK

WAVENUMBERS SCALE IN CM⁻¹



Action of base on the epoxytosylate (75)

To a solution of the epoxytosylate (75) (0.99g; 0.003 mole) in methanol (4 ml) at 0°C was added a methanolic solution of sodium hydroxide (0.5g in 4 ml methanol) in one lot and left at that temperature for 3 hours. The reaction mixture was diluted with brine, extracted with ether, washed well with brine and finally with water and the solvent distilled off. The viscous residue on distillation gave (112) as a pleasant smelling oil b.p. 142° C/ 1 Torr (200 mg)

I.R. (liquid film)  $\bar{\nu}$  in  $\text{cm}^{-1}$  7 (Spectrum 18)

3450, 3360 (broad), 1720 (S), 1605 (M), 1490 (W), 1460 (M)  
1370 (S), 1290 (M), 1230 (W), 1175 (S), 1090 (S), 1040,  
1015 (broad), 950 (M), 900 (M), 840 (M), 810 (S)

P.M.R (Spectrum 19)

2.05 ppm, (3H singlet); 6.75 ppm. (1 H)

Mass (Spectrum 20)

m/e 182 (3%); 165 (40%), 137(100%), 111 (50%)

5,5-Dimethylcyclohexan-1,3-dione (Dimedone) (113)

To a solution of sodium ethoxide (prepared from 11.5g sodium metal and 200 ml absolute ethanol) was added in one lot diethyl malonate. Then freshly distilled mesityl oxide (50g, 0.51 mole) was introduced drop-wise and with stirring. After

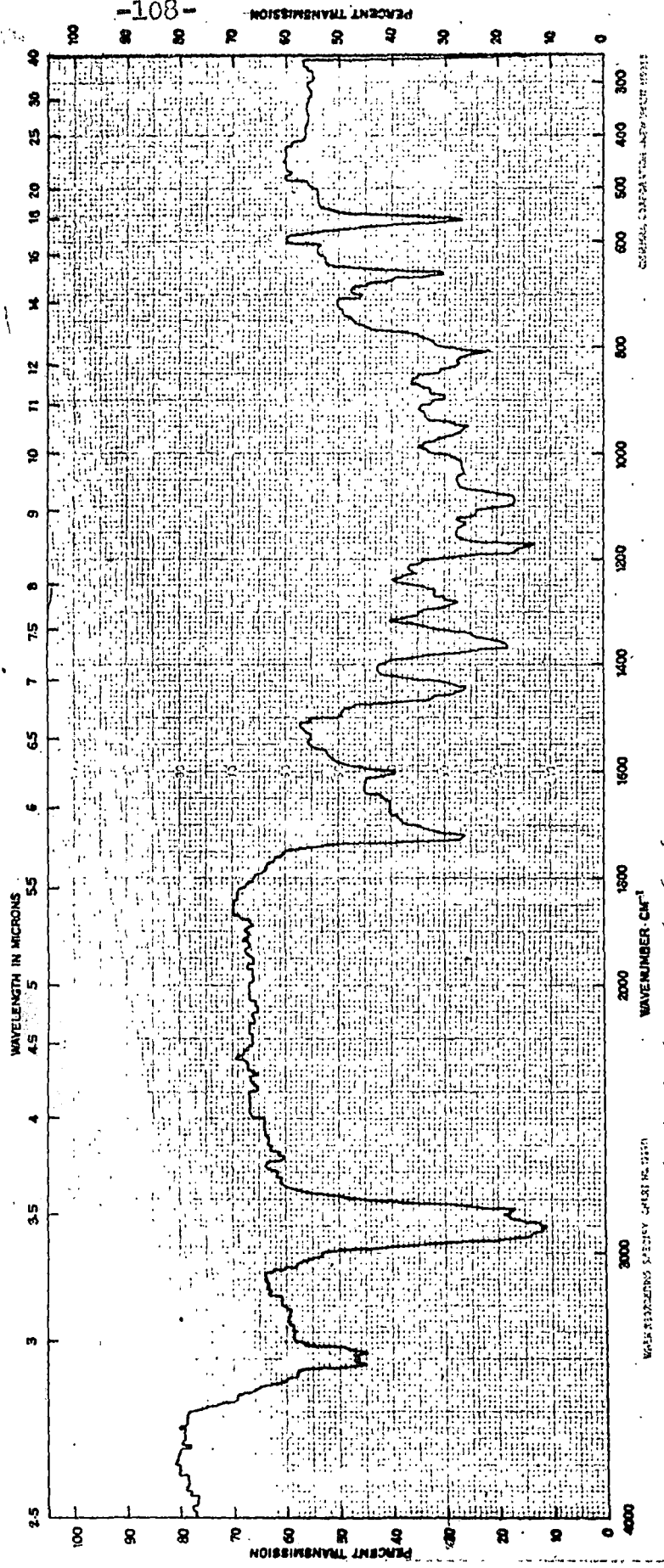

COPIED BY THE NATIONAL BUREAU OF STANDARDS

WAVENUMBER, CM⁻¹

WAVELENGTH, MICRONS

Spectrum 18

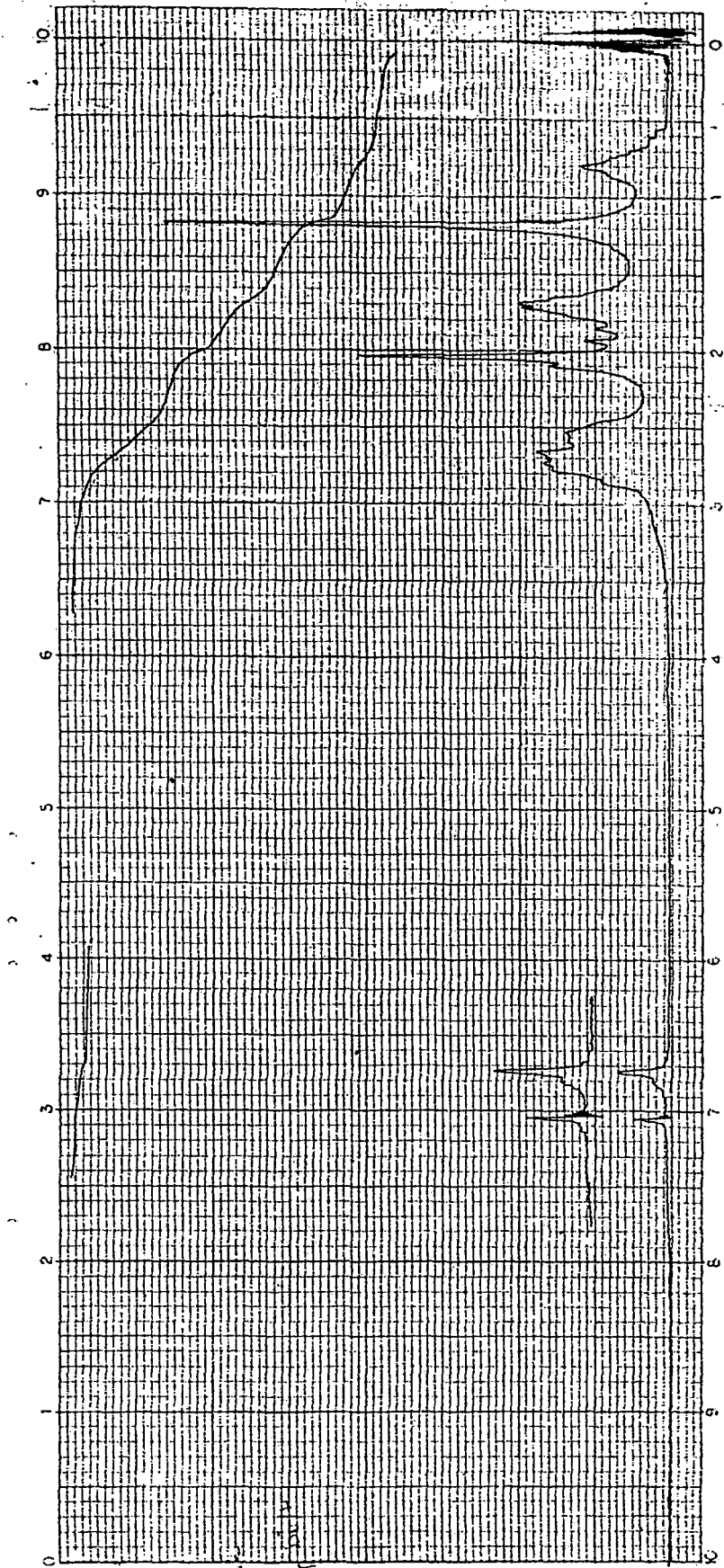

MS 150 17. 2. 50

PART NO. 5500-6671

Spectrum 19

MASS SPECTRUM : (4 TO 5)  
SAMPLE : AM/FR/LIQ-1, DR. A.K. GHOSH, N.W. UNIVERSITY  
NOTE : 4TH. AUG. 82  
BASE PEAK : M/E 137.0 INT. 130.4

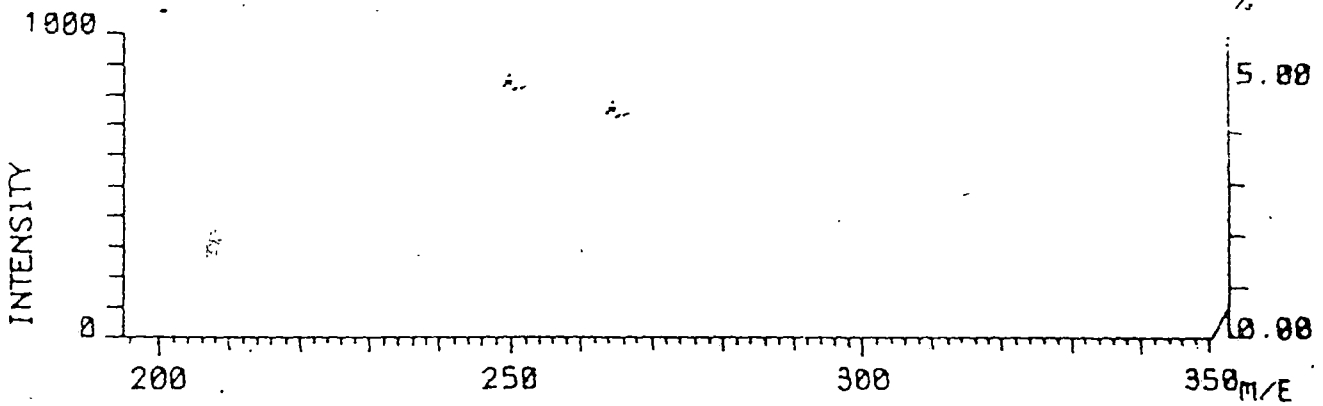
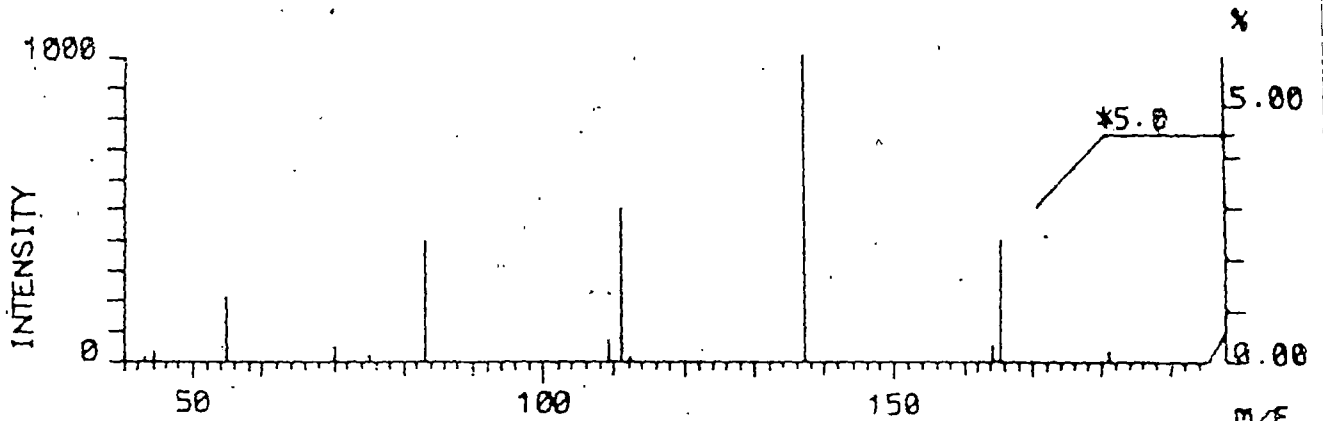

the addition the reaction mixture was refluxed for 2 hours with stirring. A solution of potassium hydroxide (62.5 g in 500 ml water) was added and the reaction mixture was refluxed for a further period of 6 hours. The reaction was acidified while still hot with dilute hydrochloric acid (1:2 by volume). After removing most of the alcohol by distillation, the reaction mixture was boiled for about 10 minutes with decolourising charcoal (8g) and then filtered. The treatment with decolourising charcoal was repeated. The residue was neutralised to litmas by the addition of hydrochloric acid and boiled again with decolourising charcoal (8 g) and filtered. The hot yellow filtrate was made distinctly acidic to methyl orange with dilute hydrochloric acid, boiled for a few minutes and allowed to cool whereupon dimedone(113) crystallised out. It was filtered, washed with cold water and air dried. Yield 60g (84%). m.p. 147 - 148°

2,5,5-trimethyl-1,3-dioxo-cyclohexane (114)

Dimedone (56 g) was added with stirring to sodium methoxide (prepared from 10.12 g. sodium and 110 ml methanol) followed by methyl iodide (44 ml) at 5° during 30 mins. After reflux (4 hr), methanol was removed and the residue diluted with water and extracted with ether. The ethereal solution was extracted with 10% aqueous potassium carbonate and the extract acidified to precipitate (114) which was washed with water, dried and used directly in the next step. Yield 34 g (55%). Specimen crystallised from ethanol had m.p. 160°

6,6,9-Trimethyl-3,8-dioxo- $\Delta^{4,10}$ -octalin (116)

The dione (114) (14.4 g), 4-diethylaminobutan-2-one (16.5g), pyridine (10.5 ml) and benzene (150 ml) were refluxed (15 hours) using a Dean-Stark apparatus. Usual work up gave 2,5,5-trimethyl-2-(3'-oxobutyl)-1,3-dioxocyclohexane (17.8 g) as a viscous oil b.p. 135 - 138°/0.6 Torr.

The above triketone (13.0 g), triethylamine (7.5 ml), benzoic acid (6.8g) and xylene (75ml) were refluxed using Dean-Stark apparatus till no more water separated (20 hours). Usual work up gave, after fractionation, the desired product (116) as a pale yellow oil which solidified. It was crystallized from ether and petroleum ether, m.p. 94°  $\lambda_{\text{max}}$  243 nm ( 18,000);

Anal.  $C_{13}H_{18}O_2$  requires C, 75.73; H, 8.76%

Found C, 75.33; H, 8.49%

The 2,4-dinitrophenylhydrazone was crystallized from ethanol - chloroform. m.p. 204°;  $\lambda_{\text{max}}$  (CHCl<sub>3</sub>) 305 nm ( 17,000)

The cyclodehydration appeared to be rather sluggish presumably due to the gem-dimethyl groups which introduce intense 1,3-diaxial interaction in the intermediate aldol.

6,6,9-Trimethyl-3,8-dihydroxy- $\Delta^{4,10}$ -octalin (117)

A solution of (116) (1 g) in ether (10 ml) was added slowly to a well stirred suspension of lithium aluminium hydride in (10 ml) at room temperature. After stirring at room temperature (1.5 hours) it was decomposed at 5° (ice-bath) with saturated aqueous sodium sulphate solution. Usual work up furnished the

diol as a colourless solid which was crystallized from ether petroleum ether as needles, m.p. 180°.

The compound gave satisfactory analysis and did not show any absorption in UV characteristic of  $\alpha\beta$ -unsaturated ketones.

6,6,9-Trimethyl-8-hydroxy- $\Delta^{4,10}$ -octalin-5-one (118)

A solution of (117) (1 g) in chloroform (100 ml) and active manganese dioxide (9 g) were stirred at room temperature for 14 hours. The mixture was then filtered, the <sup>in-</sup>organic residue washed with hot chloroform (50ml X 5) and the combined filtrates dried and concentrated. The residue on distillation gave a viscous oil which solidified and after crystallization from acetone-petroleum ether had m.p. 121°,  $\lambda_{\text{max}}$  245 nm (18,000)

I.R. (major)  $\left[ \text{in cm}^{-1} \right]$  (Spectrum 21)

3400 (S), 1700(S), 1460(S), 1350, 1040(S)

Anal. calcd for  $C_{15}H_{20}O_2$  C, 75.00; H, 9.60%

Found C, 74.68; H, 9.38%

4,10-Epoxy-6,6,9-trimethyl-8-hydroxydecalin-5-one (119)

To (118) (1 g; 0.005 mole) in methanol (75 ml) cooled to 0° was added a mixture of 4N sodium hydroxide (5 ml) and 30% hydrogen peroxide (5 ml) with continuous stirring. After the addition the reaction mixture was stirred for an additional hour and left at 0°C for 72 hours. Methanol was removed on a water-bath under reduced pressure and the residue was taken up in benzene.

Spectrum 21

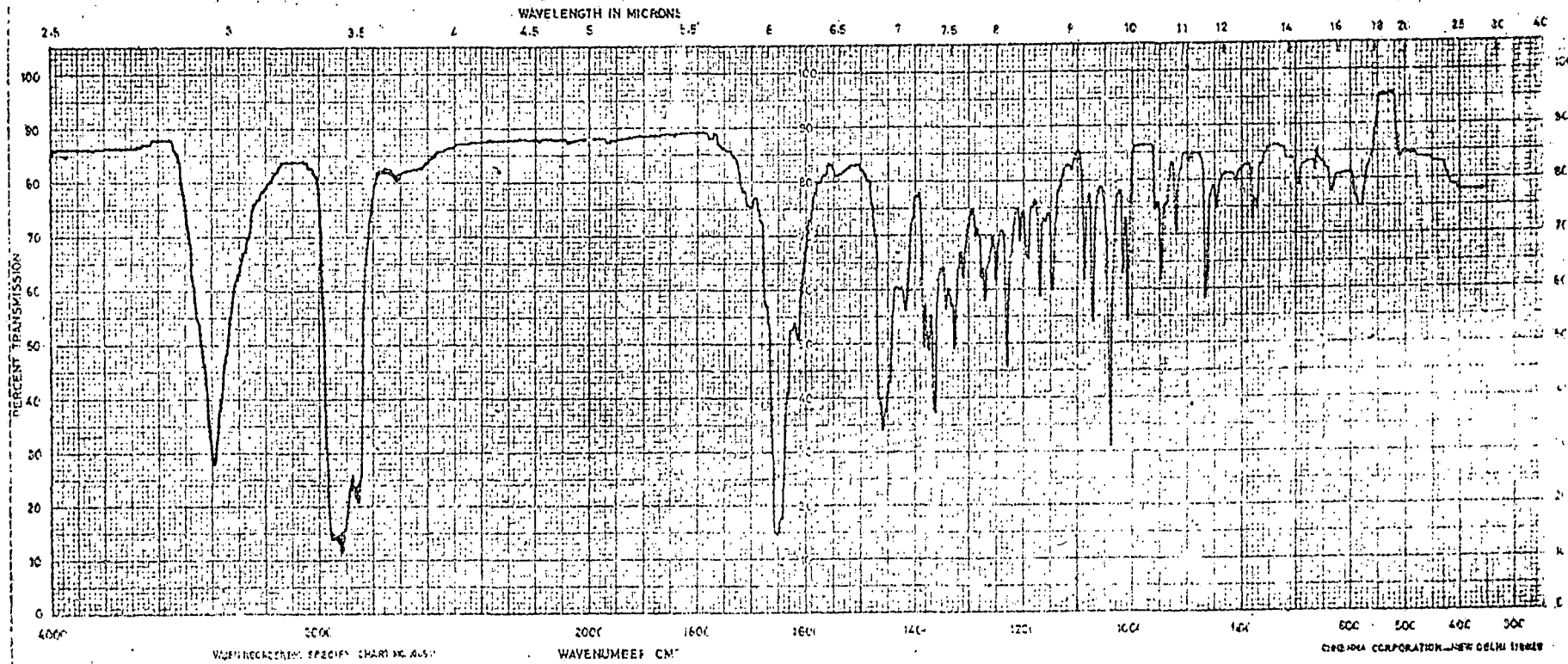

WAVELENGTH IN MICRONS

WAVENUMBER CM⁻¹

CIBA CORPORATION - NEW DELHI 110001

washed with brine until neutral, dried and concentrated. The crude epoxy compound (119) was used as such in the next step.

4,10-Epoxy-8-tosyloxy-6,6,9-trimethyldecalin-3-one (76)

The epoxy alcohol from the previous step was dissolved in absolute pyridine (3 ml) and treated with freshly distilled para toluenesulphonyl chloride (2.5 g) and left at 100° for 72 hours. The reaction mixture was diluted with water and extracted with chloroform and washed with water several times and concentrated. The gummy tosylate was used as such in the next step. A small portion of the compound was crystallized from benzene - petroleum ether when the tosylate separated as a white crystalline solid m.p. 140°C.

Action of base on (76)

To a solution of the crude tosylate (76) (1 g) in methanol (20 ml) at 0° was added a methanolic solution of potassium hydroxide (0.5 g in 10 ml) in one lot and left at that temperature for 1 hour with occasional stirring. Methanol was removed under reduced pressure. The residue was diluted with brine and extracted with ether. Ether extract was washed successively with brine, dilute hydrochloric acid, aqueous sodium bicarbonate and finally with brine until neutral and concentrated.

The residue was adsorbed on a short column of active alumina (basic) and eluted with benzene. Solvent was distilled off and the residue on distillation gave a pleasant smelling

liquid formed by the elimination of the tosyloxy group ( $\eta/\epsilon$  224)

The compound appears to be impure and a mixture as is evident from the infrared and p.m.r spectra. (Spectra 22 & 23)

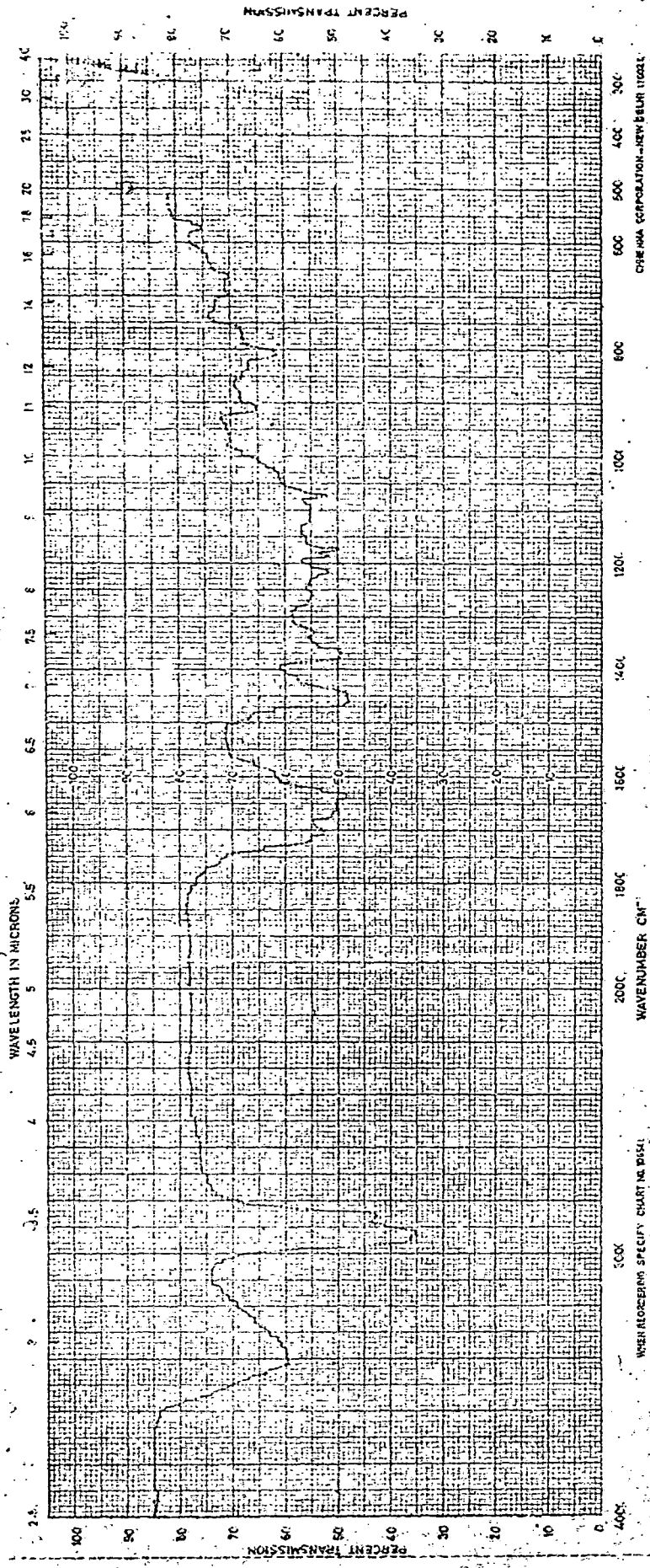

CHEMISA CORPORATION - NEW BRUNSWICK

WHEN RECORDING SPECIFY CHART NO. 10541

Spectrum 22



PART I

REFERENCES

1. H.Hibbert and N.M. Carter, J.Am.Chem. Soc., 50, 3120 (1928)
2. L.Ruzicka, M.Stoll and H.Schinz, Helv. Chim. Acta, 9, 249 (1926)
3. K.Zeigler, H.Eberic and H.Ohlinger, Ann., 504, 94 (1933)
4. P.Ruggli Ann., 392, 92 (1912); 399, 174 (1913); 412, 1, (1917).
5. V.L.Hansley, US Patent 2,228,268 (1941), Chem. Abstr 35, 2534, (1941); V.Prelog, L.Frenkiel, M.Kobelt and P.Barman, Helv. Chim. Acta, 30, 1741 (1947); M.Stoll and J.Hulstkamp, ibid., 30, 1815 (1947); M.Stoll and A.Rouve, ibid., 30 1822 (1947)
6. A.C.Sope and E.C. Herrick, J.Am.Chem. Soc., 72, 983 (1950)
7. J.C. Sheehan R.C.Codefre J.Am.Chem. Soc., 75, 3997, (1953)
8. V.Prelog, J.Chem. Soc., 420 (1950)
9. S.Kaarsemaker and J.Coops, Rec. trav. chim.71, 261 (1952)
10. J.W.Knowlton and F.D.Rossini, J. Research Natl.Bur. Standards 43, 113 (1949)
11. R.Spitzer and H.M.Huffman J.Am.Chem. Soc., 69, 211 (1947)
12. J.Coops, H.Van Kamp, W.A.Lambregts, B.J.Visser and H. Dekker, Rec. trav. chim., 79, 1226 (1960)
13. H.C. Brown, R.S.Fletcher and R.B.Johannesen, J.Am.Chem.Soc., 73, 212 (1951)
14. A. von Baeyer, Ber., 18, 2277 (1885)
15. H.Sachse, Ber., 23, 1363 (1890); Z. Physik. Chem., 10, 203, (1892)
16. E.Mohr, J.Prakt. Chem., 98, 316, (1918)
17. N.J.Demjanov and M.Dojarenko, Ber., 56, 2200, (1923)
18. J.R. Nunn, J.Chem. Soc., 313, (1952)
19. R.Breslow, R.Haynie and J.Mirra, J.Am. Chem. Soc., 81, 247 (1959); R.Breslow and R.Peterson, ibid., 82, 4426 (1960)

M.E. Volpin, Y.D. Koresnikov and D.N. Kursanov, Izvest. Akad. Nauk S.S.S.R., Otdel. Khim. Nauk, 560 (1959) English translation p. 555.

20. a) W. Baker and J.F.W. McOmie, Cyclobutadiene and Related compounds in D. Ginsburg Ed. "Nonbenzenoid Aromatic Compounds" Interscience Publishers inc., New York 1959 pp 43 - 195.  
b) W.N. Lipscomb, Tetrahedron Letters 18, 20 (1959)
21. M. Avram, E. Marica and C.D. Nenitzescu Chem. Ber., 92, 1088 (1959); M. Avram, Ch. Mateescu, I.G. Dinulescu, E. Marica and C.D. Nenitzescu Tetrahedron Letters 21, (1961)
22. R. Criegee and C. Schroder Angew. Chem 71, 70 (1959)
23. A.E. Favorskii, J. Gen. Chem., (U.S.S.R.) 6, 720 (1936)  
L. Skattebøl, Tetrahedron Letters 167 (1961)
24. A.T. Blomquist and L.M. Liu, J. Am. Chem. Soc., 75, 2153, (1953); N.M. Dornin, J. Gen. Chem (U.S.S.R.) 8, 851, (1958)
25. D.J. Cram and N.C. Allinger, J. Am. Chem. Soc., 78, 2518 (1956)
26. F. Sondheimer, Y. Amiel and R. Wolovsky, J. Am. Chem. Soc., 79, 6263 (1957)
27. F. Sondheimer, Y. Amiel and R. Wolovsky, J. Am. Chem. Soc., 79, 4247, (1957)
28. F. Sondheimer and R. Wolovsky J. Am. Chem. Soc., 81, 1771, (1959); Tetrahedron Letters, No3, 3 (1959)
- 28a F. Sondheimer, R. Wolovsky and D.A. Ben-Efrain, J. Am. Chem. Soc., 83, 1686 (1961)
29. K. Zeigler and H. Wilms, Ann., 567, 1, (1950)
30. R.B. Turner and W.R. Meador, J. Am. Chem. Soc., 79, 4133 (1957)
31. A.C. Cope, P.T. Moore and W.R. Moore, J. Am. Chem. Soc., 81, 3153 (1959)
32. M.P. Cava and D.R. Napier, J. Am. Chem. Soc., 78, 500 (1956)
33. W.C. Cuthrop, J. Am. Chem. Soc., 63, 1187, (1941)
34. A. Luttringhaus, Ann., 528, 181, (1936)
35. V. Prelog and K. Wiesner, Helv. Chim. Acta, 30, 1465, (1947)

36. V. Prelog, K. Wiesner, W. Ingold and C. Hafliger, *Helv. Chim. Acta*, 31, 1325 (1948)
37. V. Prelog, P. Berman and H. Zimmerman, *Helv. Chim. Acta*, 33, 356 (1950)
38. N. J. Leonard and Owens, *J. Am. Chem. Soc.* 80, 6039 (1958)
39. F. Sorn in Lechnolster ed., *Progress in the Chemistry of Natural Products*,
40. A. Luttringhaus, *Ber.*, 72, 837 (1939); (b) *Ann.*, 528, 223 (1936); (c) *Ann.*, 528, 211 (1936)
41. A. Luttringhaus and K. Buchholz, *Ber.*, 72, 2057 (1939)
42. A. Luttringhaus and R. Kohlhass *Ber.*, 72, 907, (1939)  
R. Kohlhass and A. Luttringhaus *Ber.*, 72, 897 (1939)
43. D. J. Cram and H. Steinberg, *J. Am. Chem. Soc.*, 73, 5391 (1951)
44. D. J. Cram and H. F. Antar, *J. Am. Chem. Soc.*, 80, 3103 (1958)
45. C. J. Brown *J. Chem. Soc.*, 3265 (1953)
46. K. C. Dewhurst and D. J. Cram, *J. Am. Chem. Soc.*, 80, 3115 (1958)
47. K. Pellegrin, *Rec. trav. chim.*, 18, 457, (1899)  
W. Baker, J. F. W. McOmie and J. M. Norman, *J. Chem. Soc.*, 1114 (1951)
48. H. Steinberg and D. J. Cram *J. Am. Chem. Soc.*, 74, 5388 (1952); E. D. Bergman and E. Pelchowicz, *ibid.*, 75, 4281 (1953)
- 48a. G. Wittig and J. E. Grolig, *Chem. Ber.*, 94, 2148 (1946)
49. G. S. Hammond and H. G. Newman ed., "Steric Effects in Organic Chemistry," John Wiley & Sons Inc. New York 1956, pp 460 - 470; E. L. Eliel, *ibid.*, pp 117 - 120; C. K. Ingold, "Structure and Mechanism in Organic Chemistry," Cornell University Press, Ithaca, N. Y., 1953 pp 537 - 543; J. W. Baker, "Tautomerism," D. Von Nostrand Company Inc., Princeton, N. J. 1954 Chap 10.
50. K. Auwers and V. Meyer, *Ber.*, 23, 101, 293 (1890)  
K. Auwers and E. L. Jackson *ibid.*, 23, 1599 (1890)
51. P. E. Verkade, *Rec. trav. chim.*, 40, 199, (1921)

52. S.Gabriel, Ber., 19, 2565 (1886); 20, 1198 (1887)
53. E.H. Farmer and J.Kracovski, J.Chem. Soc., 680, (1927)
54. R.Anschutz, Ann., 254, 168 (1889)
55. R.M. Beesley, C.K. Ingold and J.F. Thorpe J.Chem. Soc., 1080 (1915); C.K. Ingold, *ibid.*, 305, (1921)
56. S.Searles, E.F. Lutz and M. Tamres J.Am. Chem. Soc., 82, 2932, (1960)
57. P. von R.Schleyer, J.Am. Chem. Soc., 83, 1538 (1961)
58. A.Luttringhaus and K.Buehholz Ber., 73, 134 (1940)
59. N.L. Allinger and V. Zalkow J.Org. Chem., 25, 701 (1960)
60. J.D. Dunitz and V.Prelog, Angew. Chem., 72, 896 (1960)  
V. Prelog, Pure and Appl. Chem 545 (1963); J. Dals  
Angew. Chem., 73, 1070 (1966); J. Dunitz, Pure and  
Appl. Chem., 2, 495 (1971)
61. R.Srinivasan and T.Srikrishnan, Tetrahedron 27, 1009 (1971)
62. P. Dowd *et al* J.Am. Chem. Soc., 92, 6325 (1970)
63. G. Borgen and J. Dale / Chem. Commun., 1105 (1970)
64. O.Ermer and J.D. Dunitz Chem. Commun., 178 (1971)
65. J.Sicher *et al* Tetrahedron 22, 659 (1966)
66. M. Bixon *et al.*, Collect. Czech. Commun. 32, 358, (1967)
67. W.Fedeli and J.D. Dunitz, Helv. Chim. Acta, 51, 445 (1968)
68. N.L. Allinger and J.J. Maul, Tetrahedron 24, 4857 (1968)
69. H.Dahn, H.P.Schluke and J.Tenier, Helv. Chim. Acta., 55, 907, (1972)
70. R. Borsdorf and A.Preiss J. Prakt. Chem., 311, 36, (1969)
71. R.D. Stolow, T.Groom and P.D. McMaster, Tetrahedron Letters: 5781 (1968)
72. A.C. Cope, H.E. Johnson and J.E. Stephenson, J. Am. Chem. Soc., 78, 5599 (1956)

73. Tiffeneau, Weil and Tchoubar *Comp rend* 205, 54 (1937)  
212, 195, (1941); *Bull. Soc. Chim., France* 160 (1949)
74. A. Eschenmoser and A. Frey, *Helv. Chim. Acta*, 35, 1660  
(1952)
75. (a) P.S. Wharton, *J. Org. Chem.*, 26, 4781 (1961)  
(b) E.J. Corey *J. Am. Chem. Soc.*, 85, 362 (1963); *ibid.*,  
86, 485 (1964)
76. M. Miyashita, T. Yanara and A. Yoshikosi *Tohoku Daigaku  
Himiyogeki Kagaku Kenkyusho, Hokoku* 23, 47 (1973) (Japan)  
*Chem. Abstr.* 81, 135510j (1974)
77. J.H. Brown, T.M. Cressp and L.N. Mander *J. Org. Chem.*,  
42, 3984 (1977)
78. C.A. Grob, H.R. Kiefer, H. Lutz and H. Wilkens,  
*Tetrahedron* 39, 2901 (1964)
79. C.A. Grob, *Experientia*, 13, 126 (1957)
80. R.D. Clayton, H.B. Henbest and Michael Smith, *J. Chem. Soc.*,  
1982 (1957)
81. R. Spitzer and H.M. Huffman *J. Am. Chem. Soc.*, 69, 211 (1947)
82. C.A. Grob, H.R. Kiefer, H.J. Lutz and H.J. Wilkens,  
*Helv. Chim. Acta*, 50, 416, (1967)
83. P.S. Wharton, G.A. Hiegel *J. Org. Chem.*, 30, 3354 (1965)
84. P.S. Wharton, G.A. Hiegel and R.V. Coombs, *J. Org. Chem.*,  
28, 3217 (1963)
85. (a) M.L. Goering, W.D. Closson and A.C. Ohn, *J. Am. Chem. Soc.*,  
83, 3507 (1961)  
(b) E.M. Kosover, W.D. Closson, M.L. Goering and J.C.  
Gross, *J. Am. Chem. Soc.*, 83, 2013 (1961)
86. Nomenclature proposed by W. Klyne and V. Prelog, *Exper-*  
*ientia* 16, 521, (1960)
87. H.O. House and W.F. Gilmore *J. Am. Chem. Soc.*, 83  
3972 (1961)
88. A.S. Dreiding and Tomaszewski *J. Am. Chem. Soc.*, 77,  
412 (1955)
89. W.G. Dauben, McFarland and Rogan *J. Org. Chem.*, 26, 297  
(1961)
90. Islam and Raphael *J. Chem. Soc.*, 4086, (1952)
91. P.C. Mukherji, P.K. Sengupta and G.S. Sambamurti *Tetra-*  
*hedron* 25, 5287 (1969)

92.. Idelson and Becker, J. Am. Chem. Soc., 80, 1883  
(1958).

\*\*\*\*\*

\*\*\*\*\*

STUDIES IN ALICYCLIC SYSTEMS

PART IX

SYNTHESIS AND REACTIONS OF 1,2-BIS-(2'-OXOCYCLOHEXYL)-

ETHANE

Interest in spiro compounds has been revived in recent years largely because a number of spiro compounds have been isolated from natural sources in recent years. The most note-worthy of these is  $\beta$ -vetivone (I) which until 1960's was considered to be a hydrazulene derivative (II). The pioneering work of Marshall<sup>1</sup> unequivocally established the spirodecane structure of this compound. This has had a catalytic effect in the revival of interest in the spiro compounds in general and spiro sesquiterpenes in particular. The number of syntheses that have appeared in literature and their variety bears an ample testimony to this fact.

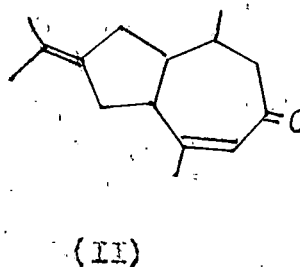
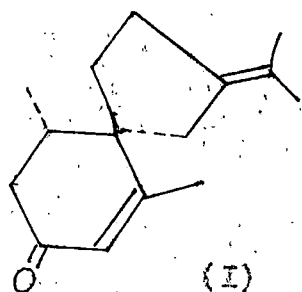

One of the methods of synthesis of spiranes is by way of condensation of  $\alpha, \omega$ -dialdo compounds with cyclic ketones. A review of this and other reactions leading to the carbocyclic

spiro compounds has appeared in literature.<sup>2</sup> Christol et al<sup>3</sup> who developed this method of synthesis of spiro compounds - the di- and tetra- alkylations of ketonic substrates with  $\alpha,\omega$ -dihaloalkanes - have reported that whereas the alkylation of cyclohexanone with 1,5-dibromopropane led to 2-allylcyclohexanone there was no reaction with 1,2-dibromoethane. With other  $\alpha,\omega$ -dihaloalkanes like 1,4-dibromobutane and 1,5-dibromopentane spirocompounds could be obtained. Apparently these authors were looking for spirocompounds only. We were not aware of this work when we attempted the reaction of cyclohexanone with 1,2-dibromoethane in presence of sodium ethoxide in ethanol. We could isolate an appreciable amount of a white crystalline solid m.p. 155°. The compound was found to have been formed by the condensation of two moles of the ketone with one mole of the dibromo compound. A study of the mass spectrum of the compound (m/e 222) clearly showed that the compound is the hitherto unreported 1,2-bis-(2'-oxocyclohexyl)-ethane (III). The IR spectrum of the compound was almost identical with that of (IV) described by Camps.<sup>4</sup>

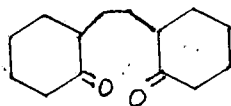

(III)

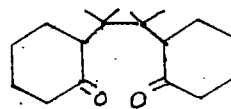

(IV)

Interestingly Camps has prepared the compound (IV) in a nine-step

sequence starting from cyclohexanone as shown in the chart below:

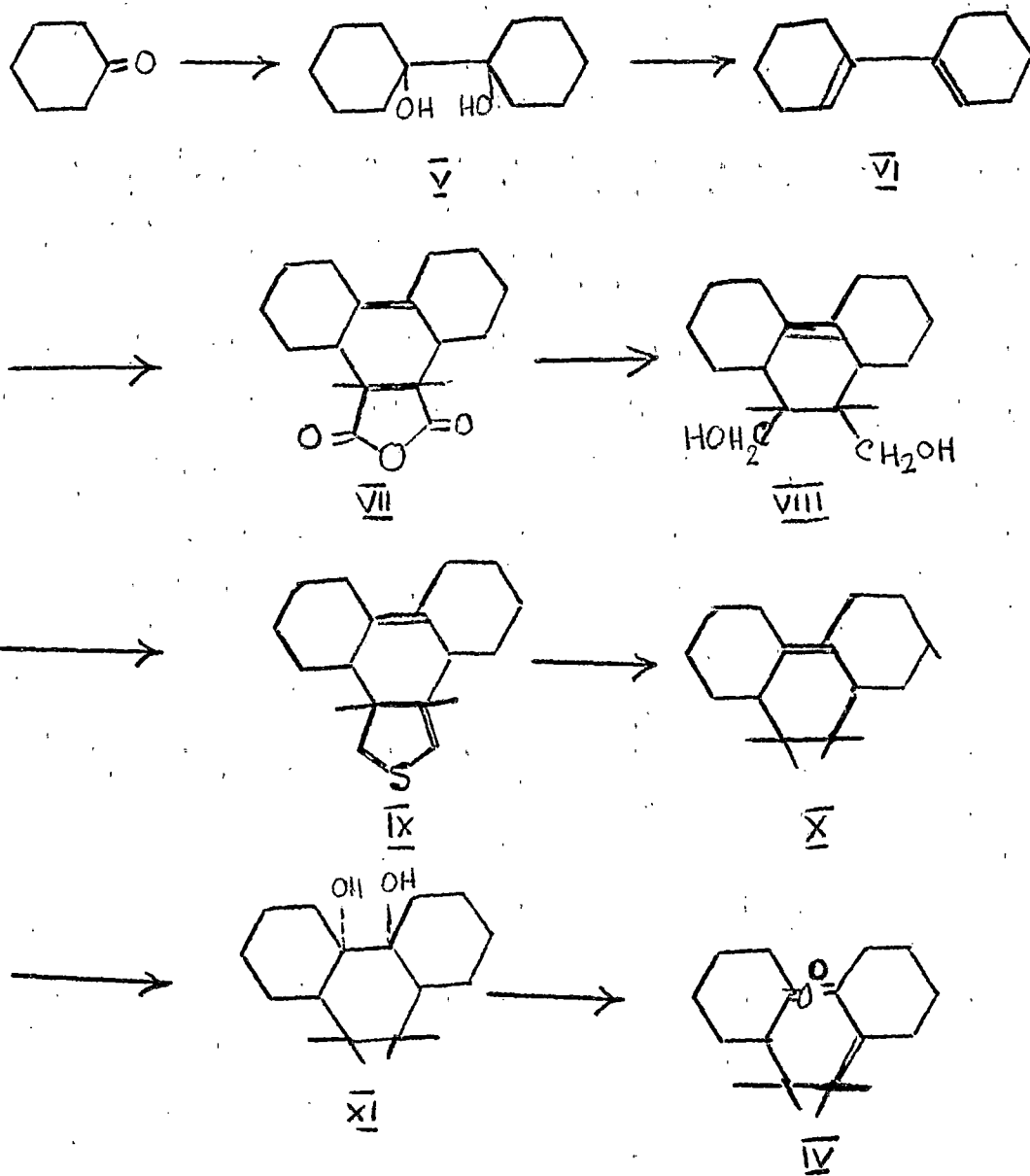
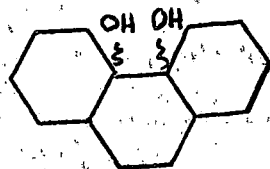

CHART I

Reduction of cyclohexanone with aluminium amalgam in benzene gave the pinacol (V) which on dehydration gave the diene (VI). Diels-Alder reaction with dimethylmaleic anhydride gave the tetracyclic compound (VII) which on reduction with lithium aluminium hydride gave cis 9,10-dimethyl-9,10-di-(hydroxymethyl)-  
-  $\Delta$  <sup>4a(4b)</sup> - perhydrophenanthrene (VIII) which was converted to the sulphide (IX) by standard reactions. Desulphurisation with Raney Nickel gave the tetramethyl compound (X) which was hydroxylated with osmium tetroxide to (XI). Oxidation of the diol with lead tetraacetate in benzene gave (IV).

We wanted to study (i) the conversion of the diketone (III) to the perhydrophenanthrenediol (XII) and study the action of acid on it and, (ii) convert the diketone to spiro system by acid/base catalysed aldol condensation. Camps et al have studied the base catalysed aldol condensation of the diketone (IV) with sodium methoxide in methanol and have reported the formation of the spiro ketoalcohol (XIII). They have, however,



(XII)

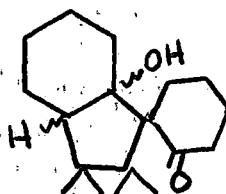

(XIII)

not studied the acid catalysed reaction of the diketone which would have led to the formation of the dehydrated compound (XIV).

1,2-Bis-(2'-oxocyclohexyl)-ethane (III) was treated with sodium amalgam in benzene under nitrogen for three hours to give a white crystalline compound m.p.  $145^{\circ}$  which in IR showed no carbonyl absorption. The compound showed a broad band at  $3400\text{ cm}^{-1}$  indicating the presence of a hydroxyl group. The mass spectrum clearly indicated (m/e 224) that the compound is the hitherto unreported perhydrophenanthrenediol (XII). Though the compound appeared to be homogeneous (TLC), it is quite likely a mixture of various perhydrophenanthrenediols with (perhaps) the trans-anti-trans isomer predominating.

We hoped that the diol (XII) would rearrange to the tricyclic ketone (XV) under the influence of acids. When the

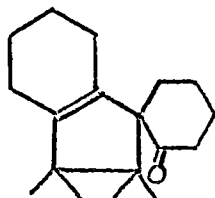

(XIV)

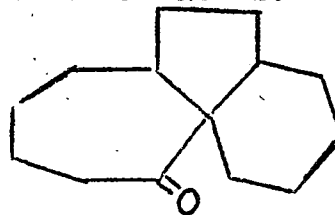

(XV)

diol was treated with concentrated sulphuric acid, an intense blood-red colour developed. The reaction mixture on working up gave a pleasant smelling oil. The molecular weight (m/e 206) indicated that the compound was formed by the loss of one molecule of water from one molecule of the compound. The IR spectrum indicated the presence of a hydroxyl group ( $3400\text{ cm}^{-1}$ ) though a weak band at  $1700\text{ cm}^{-1}$  indicated the presence of a carbonyl function. The compound is probably a mixture of (XV) and (XVI). The extremely small amount of the

Compound at our disposal was insufficient to attempt a separation. Further work is in progress.

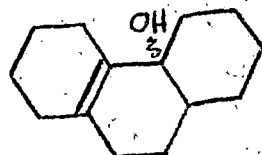

(XVI)

Next, we attempted the acid catalysed aldol condensation of the diketone (III). The compound could lead to the formation of the hitherto unknown compounds (XVII) and/or (XVIII). Clearly (XVIII) which can arise from the thermodynamically less stable enol (XIX) <sup>and</sup> ~~which~~ has the unfavourable anti-Bredt structure, cannot be formed. It is therefore more likely that the spiro compound which arises from the thermodynamically

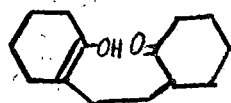

(XX)

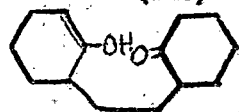

(XIX)

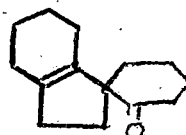

(XVII)

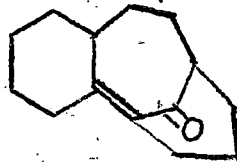

(XVIII)

more stable enol (XX) will be formed in preference to (XVIII).

Treatment of the diketone (III) with Boron trifluoride in acetic acid gave a sweet smelling oil formed by the loss

of one molecule of water. In the IR the compound showed strong absorption at 1720 <sup>-1</sup>cm. The compound has been assigned the structure (XVII).

The possibility of the compound being the tricyclic ether (XXI) which can arise by the loss of one molecule of water from the dienolic form of the diketone was ruled out on the basis of the IR spectrum.

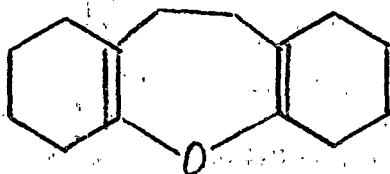

(XXI)

We expected that the diketone (III), would, like its structurally analogous tetramethyl diketone of Camps et al give the keto alcohol (XXII). But even after prolonged treatment with sodium methoxide no (XXII) could be isolated from the reaction mixture. The starting material was completely recovered. We are not able to account for this behaviour. We are attempting the reaction with other bases.

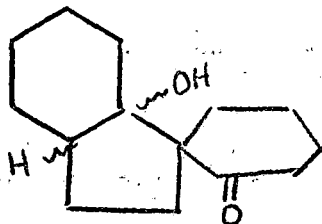

(XXII)

STUDIES IN ALICYCLIC SYSTEMS

PART II

EXPERIMENTAL

All melting points and boiling points are uncorrected. Solvents were dried over anhydrous sodium sulphate. IR spectra were recorded on Beckmann IR 20 spectrophotometer. PMR spectra were recorded on Varian 90 M Hz / 60 M Hz spectrophotometers. Mass spectra were recorded by Central Drug Research Laboratories, Lucknow and Prof Mitsuo Miyazawa of Kinki University, Japan.

1,2-Bis-(2'-oxocyclohexyl)-ethane (III)

A mixture of cyclohexanone (98 g; 1 mole) and 1,2-dibromoethane (94 g; 0.5 mole) was added in one lot to sodium ethoxide (prepared from 500 ml absolute ethanol and 23g sodium) and refluxed on a water bath for six hours. Excess alcohol was removed under reduced pressure and the reaction mixture carefully acidified with dilute hydrochloric acid and extracted with benzene, washed dried and concentrated. The gummy residue on trituration with petroleum ether gave 1,2-bis-(2'-oxocyclohexyl)-ethane as a white solid m.p. 153°. Yield 50 g.

IR in  $\text{cm}^{-1}$  (nujol) (Spectrum 24)

1700, 1446

PMR (Spectrum 25)

Mass (Spectrum 26)

m/e 222, 189, 190, 125, 98

SPECTRUM 24

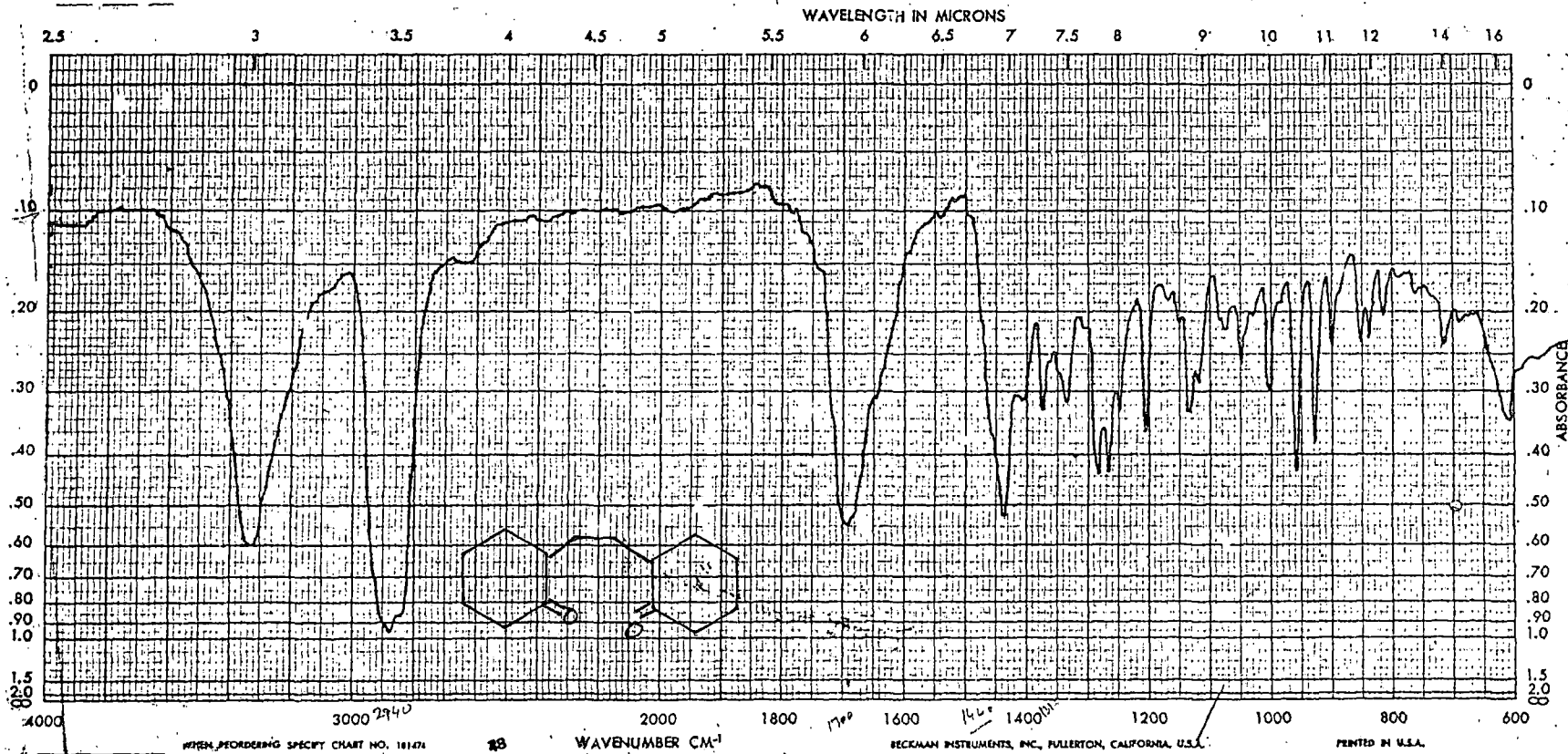

-133-

CHART S-60T

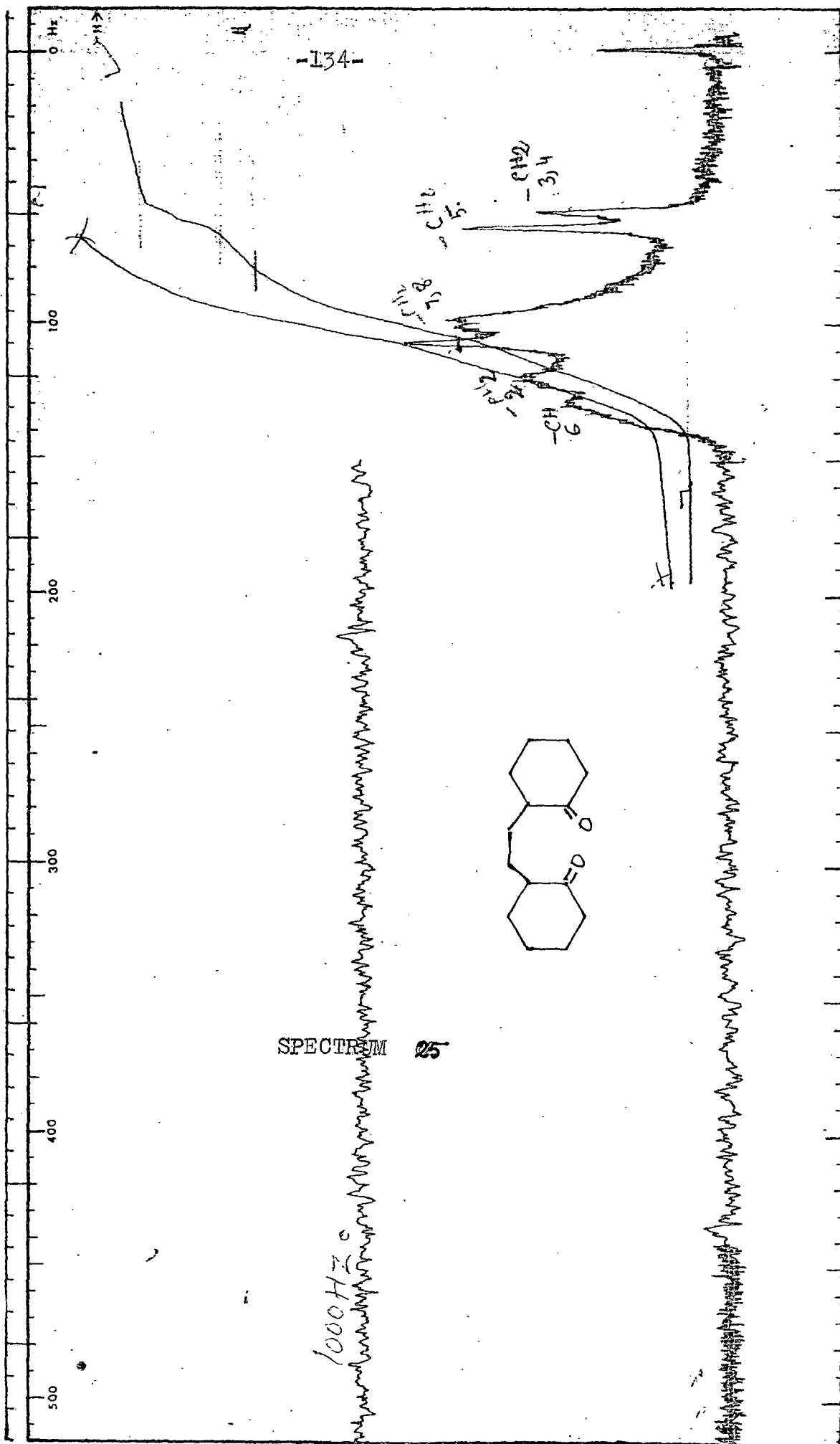

SPECTRUM

85

1000 Hz

\* MODE: EI

HV: 3500 EV: 20 / 70 TRAP: 60  
IS TEMP: 270 GAIN: 4 SCAN SPEED: 8  
COL TEMP:

DATA NO.	R.T.	PEAK	MASS RANGE	BASE PEAK	TOTAL INT'Y RAW	B.G.
18( / 2)	.0	164	50.0 - 224.0	409500( 125.0)	.2667+07	0 0

TOTAL = 15.3 %

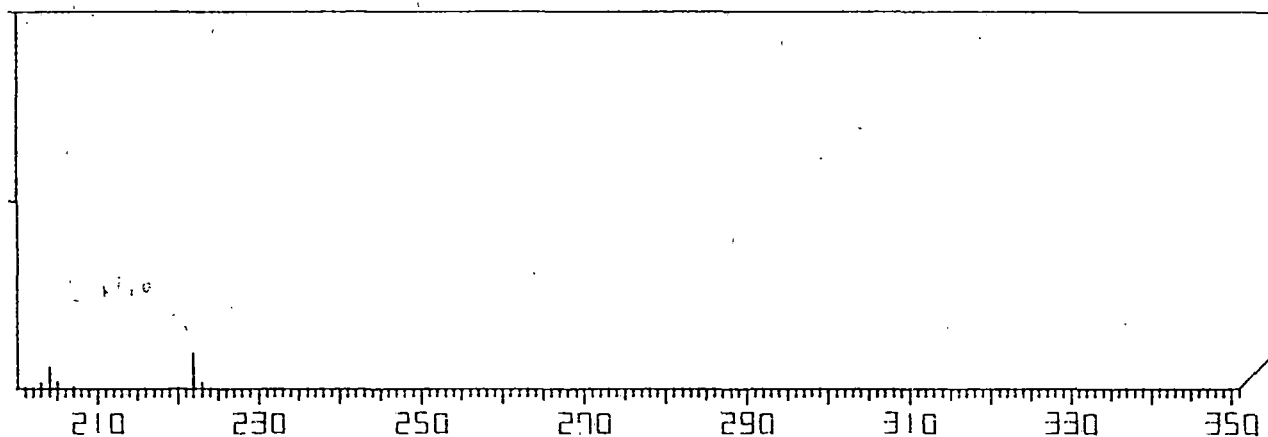
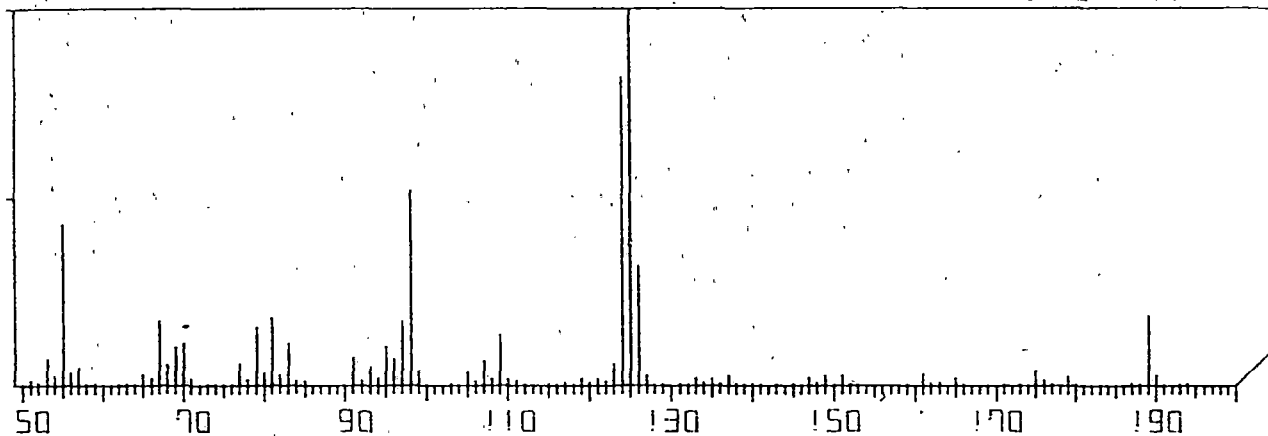

SPECTRUM 26

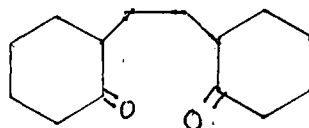

Reduction of 1,2-bis(2'-oxocyclohexyl)-ethane with Sodium amalgam:  
Formation of 4a,4b-dihydroxyperhydrophenanthrene (XII)

To sodium amalgam (prepared from 1.8g clean sodium and 10ml mercury) warmed to 50°C was added the diketone (III) (2g) dissolved in absolute alcohol (20 ml) in an atmosphere of nitrogen. Through out the addition the reaction mixture was stirred and after the addition the reaction mixture was stirred for an additional hour at room temperature and then refluxed on a water-bath for an hour more. The mixture was cooled, mercury separated, and the residue concentrated and diluted with water. The aqueous solution was extracted with benzene, washed, dried and concentrated. The dihydroxyperhydrophenanthrene (XII) separated as a white solid m.p. (from benzene-petroleum ether) 145°

IR (nujol) [in cm<sup>-1</sup>] (Spectrum 27)

3400 (broad), 1400 (S) 1370 (M)

PMR (ppm) (Spectrum 28)

3.8 (2H), 0.8 - 2.0 (multiplet)

Mass Spectrum (Spectrum 29)

m/e 224, 206, 150, 149, 108 (base peak)

Action of Conc. Sulphuric acid on the perhydrophenanthrene diol (XII). Attempted Pinacol - pinacolone rearrangement

The diol (XII) (1 g) was treated with conc. sulphuric acid (5 ml) and the reaction mixture stirred <sup>at r.t.</sup>. An intense blood-red colour developed. The stirring was continued for

OH HO

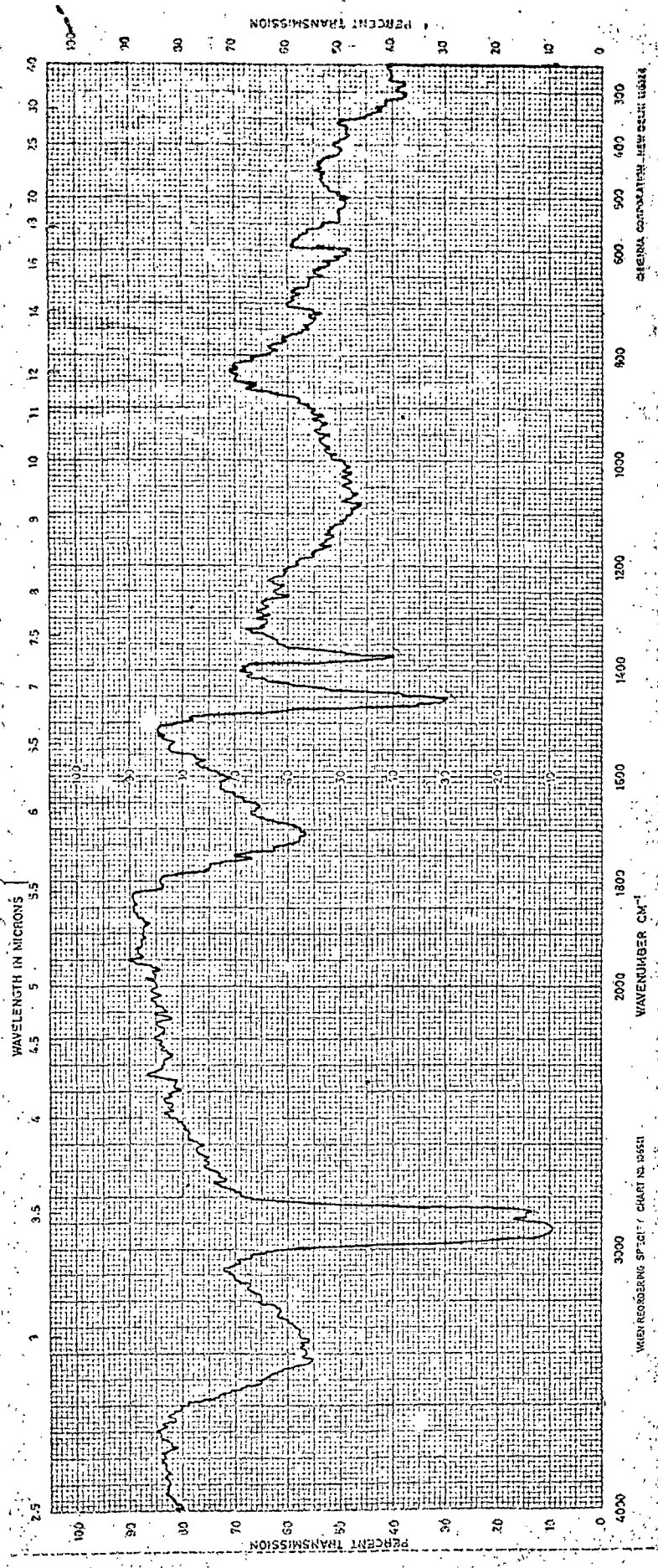

WHEN RECORDED SPEC' / CHART NO. 9551

WAVENUMBER CM<sup>-1</sup>

PERCENT TRANSMISSION

CHERNA COMPUTER - NEW CASTLE 10324

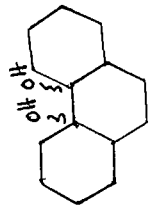

1000-1000

CHIEMMA CORPORATION -- NEW DELHI-110028

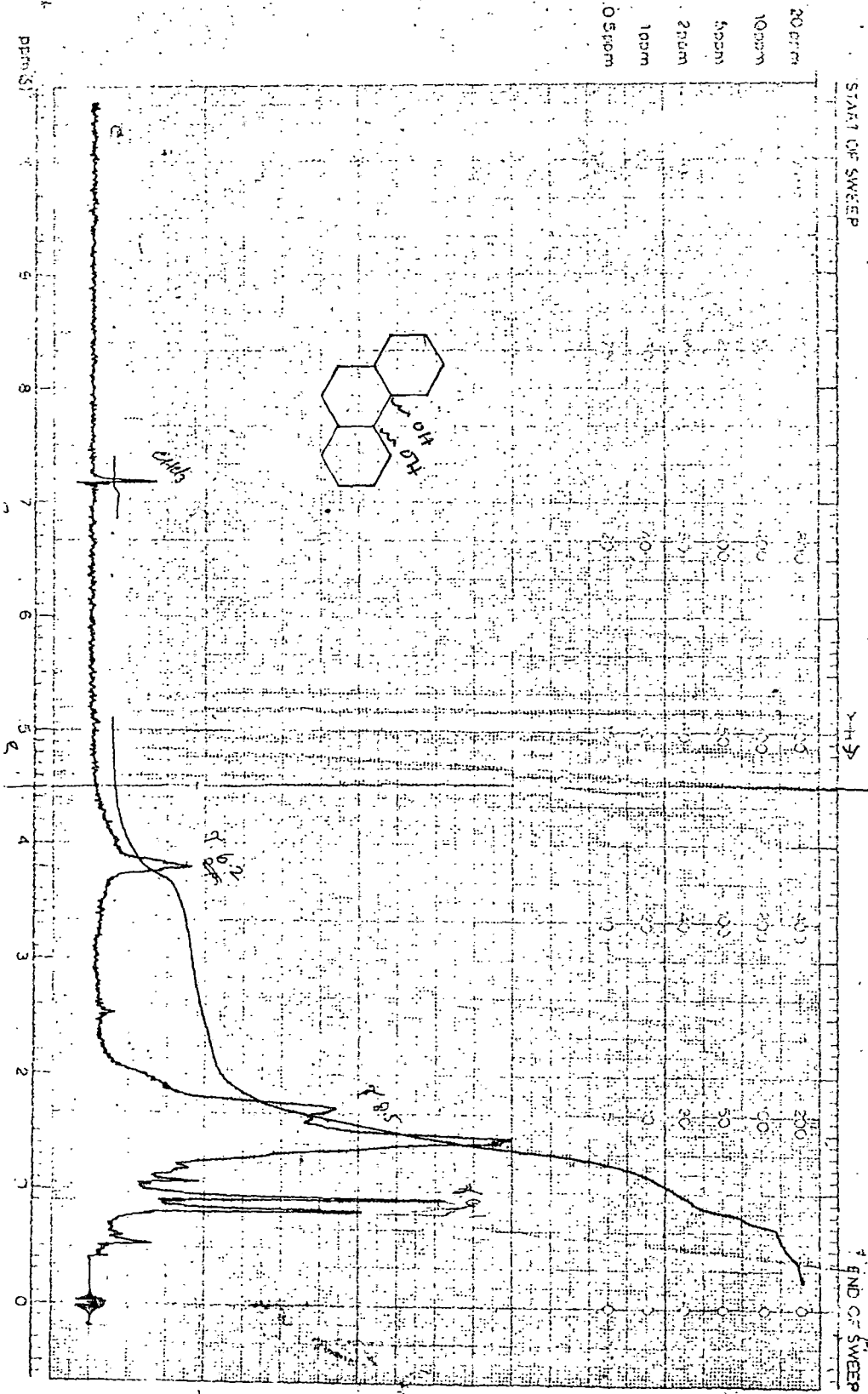

EM-360 60 MHz NMR SPECTROMETER

Spectrum 28

\* MODE: EI

HV: 3500 EV: 20 / 70 TRAP: 60  
IS TEMP: 270 GAIN: 4 SCAN SPEED: 8  
COL TEMP:

DATA NO.	R.T.	PEAK	MASS RANGE	BASE PEAK	TOTAL INT'Y RAW	B.G.
19( 3)	0	155	50.0- 278.0	195600( 108.0)	.1594+07	0 0

TOTAL = 12.2 %

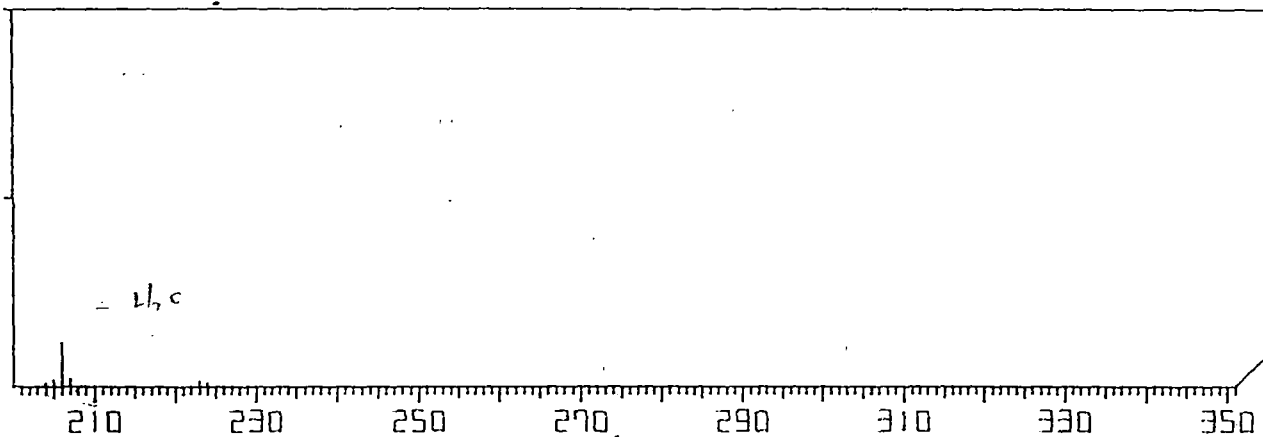
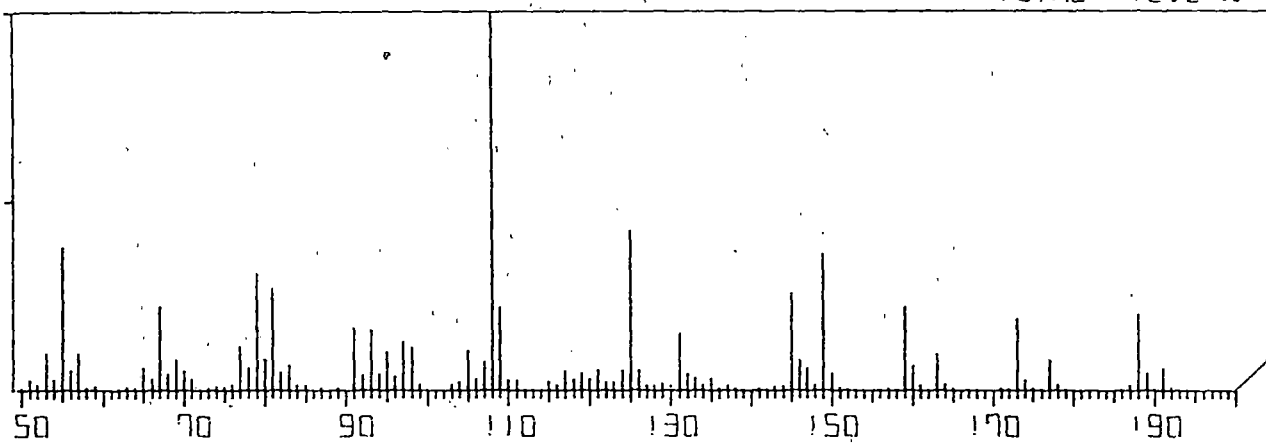

Spectrum 29

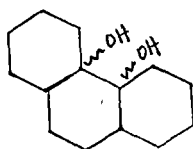

two hours and the reaction mixture was left overnight at room temperature. Next day the reaction mixture was diluted with water, extracted with benzene, washed free of acid, dried and concentrated. The residue on distillation gave a sweet smelling oil (500 mg) b.p. 138/1.5 Torr.

IR (liquid film) -  $\nu$  in  $\text{cm}^{-1}$  (spectrum 30)

3400, 2920, 1700, 1450, 1070

PMR (ppm) (Spectrum 31)

1.2 (multiplet), 3.6

Mass Spectrum (m/e) (Spectrum 32)

206, 188, 175, 159

Treatment of the diketone(III) with Boron trifluoride in Acetic acid. Formation of Spiro compound (XVIII)

The diketone (III) was dissolved in glacial acetic acid (5 ml) and treated with freshly distilled boron trifluoride in acetic acid (5 ml) and gently refluxed for one hour. The reaction mixture was diluted with water and extracted with benzene. The extract was thoroughly washed free of acid, dried and concentrated. The residue on distillation gave a pleasant smelling oil 126/1.5 Torr (800 mg).

IR (liquid film) (Spectrum 33)

2820, 2900, 1720, 1450, 1250, 1100  $\text{cm}^{-1}$

PMR (ppm) (Spectrum 34)

1.7 (multiplet)

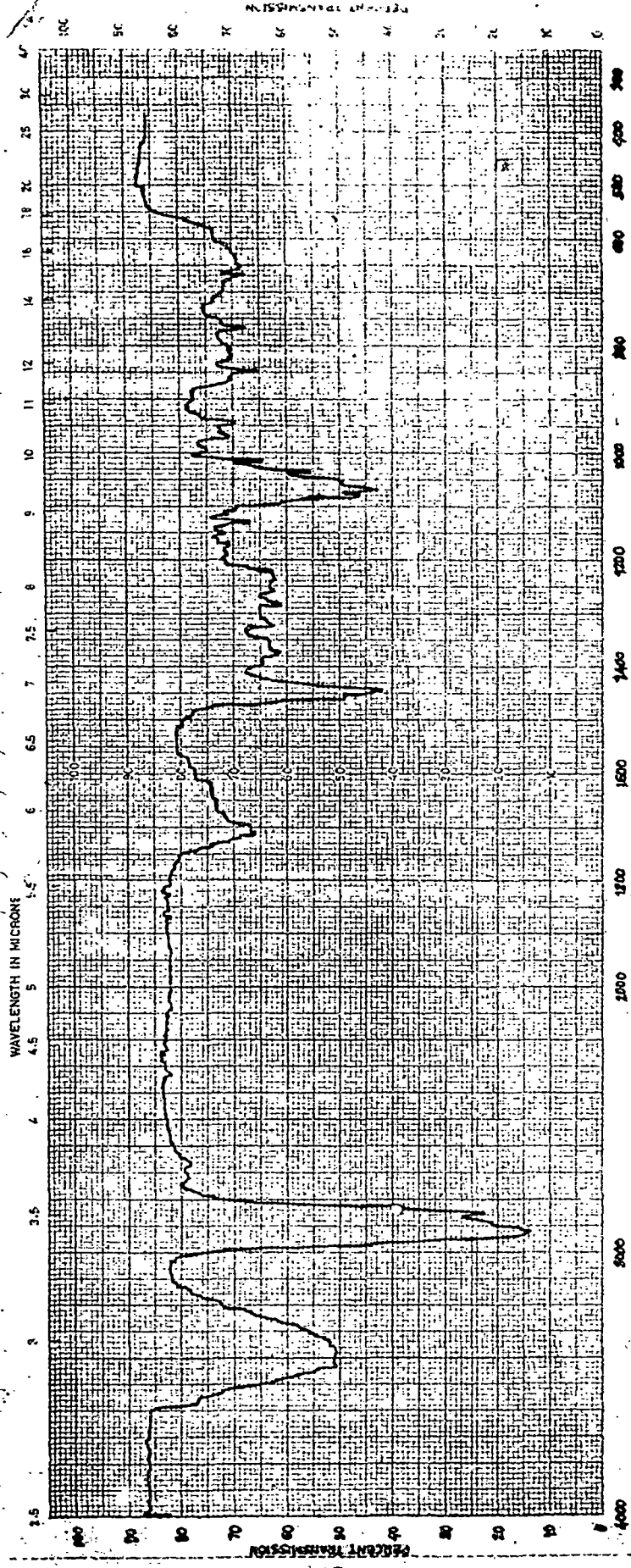

CHEMIA CORPORATION - NEW BRUNSWICK, N.J.

WAVENUMBER, CM⁻¹

WAVELENGTH IN MICRONS

H<sub>2</sub>SO<sub>4</sub> ON DIOXANE

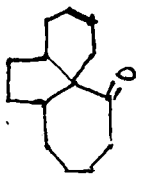

XV

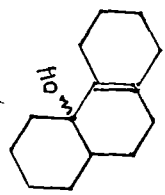

XVI

SPECTRUM 30

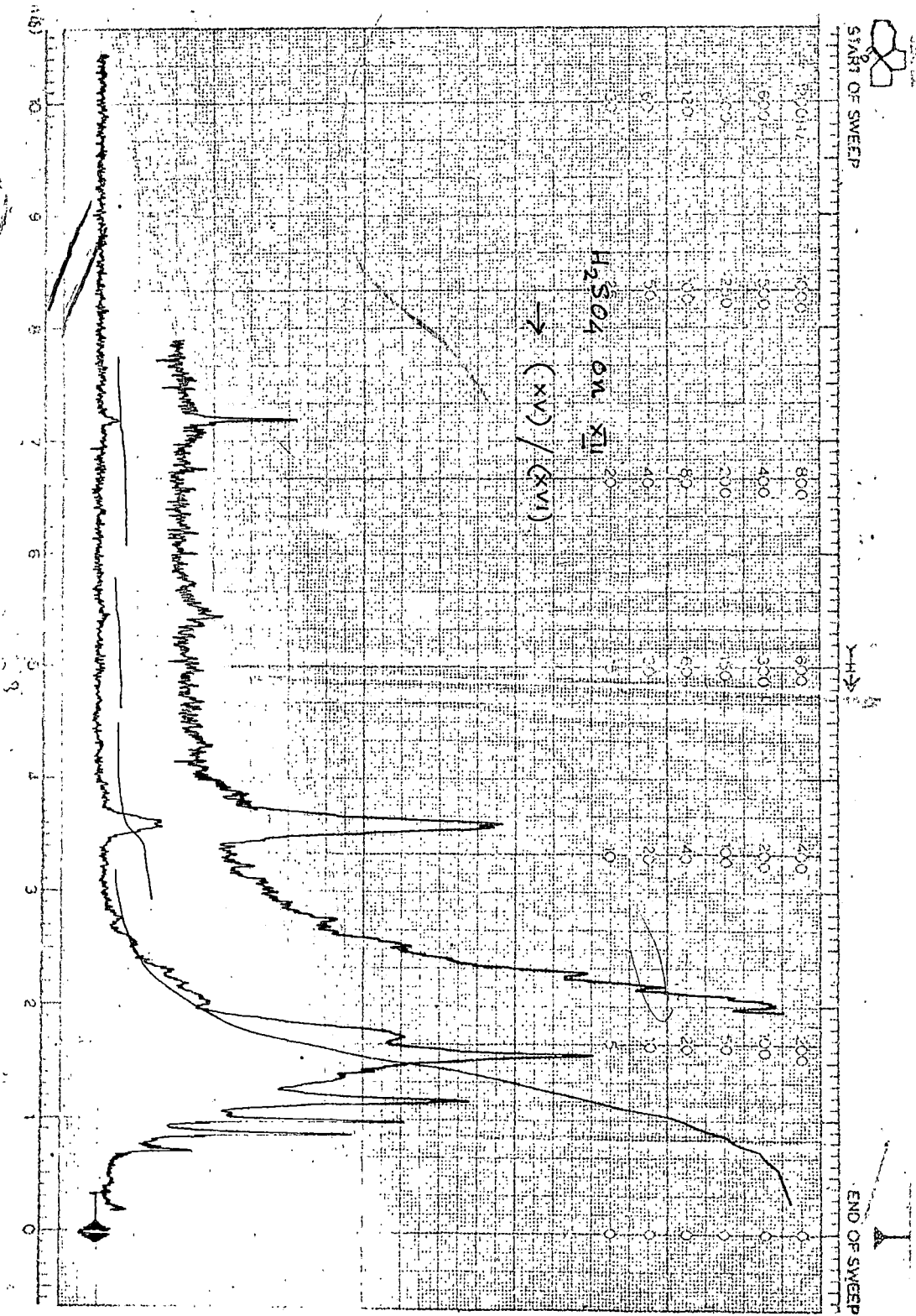

Spectrum 31

MASS SPECTRUM : (4 TO 5)  
SAMPLE CODE NO. NTL, DR (MRS) .M. MURTHI, DARJEELING  
NOTE : 13/12/83  
BASE PEAK : M/E 145.0 INT. 454.8

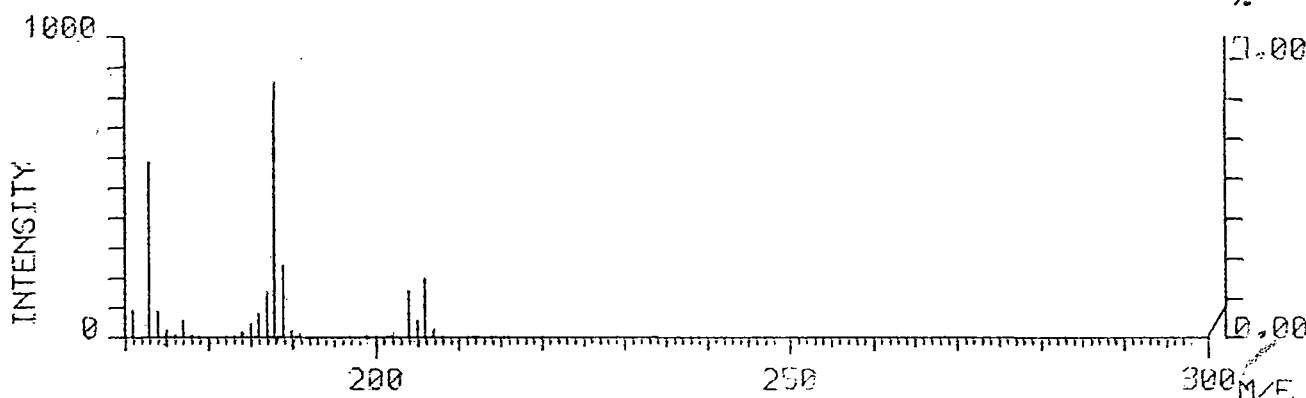
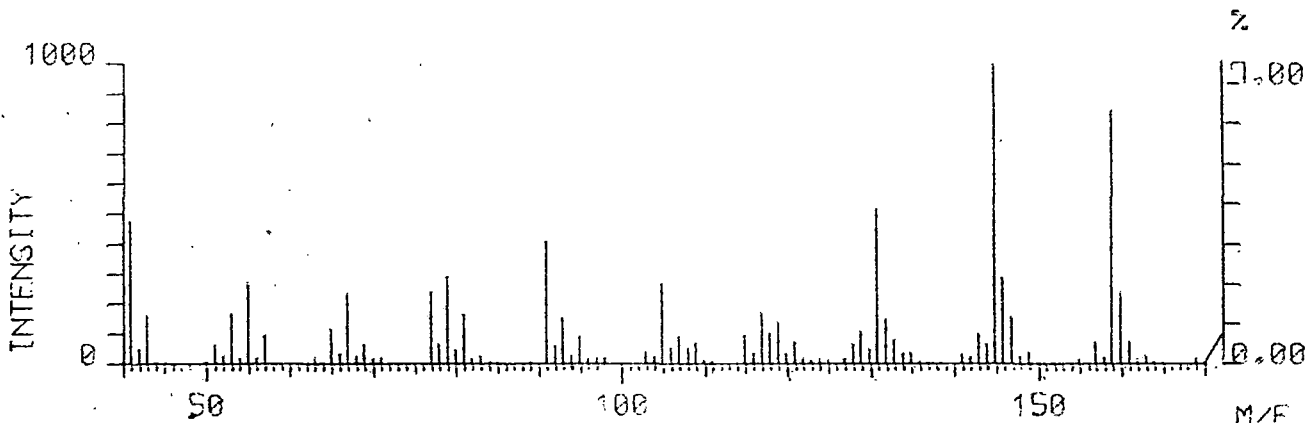

Spectrum 52

H<sub>2</sub>SO<sub>4</sub> on xii

Mass Spectrum (Spectrum 5)

204, 186, 108, 92

Action of Sodium methoxide on diketone (III): Attempted base catalysed aldol condensation

The diketone (III) (2g) was treated with sodium methoxide in methanol (300 mg Sodium in 10 ml methanol) and refluxed for 3 hours. Excess alcohol was distilled off and the residue diluted with water, extracted with benzene, washed the organic extract with water, dried and concentrated. A white solid separated which was found to be identical with the diketone (m.m.p and mixed TLC).

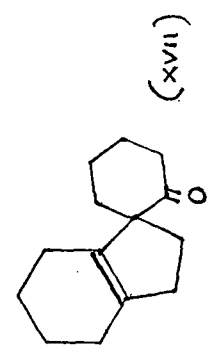
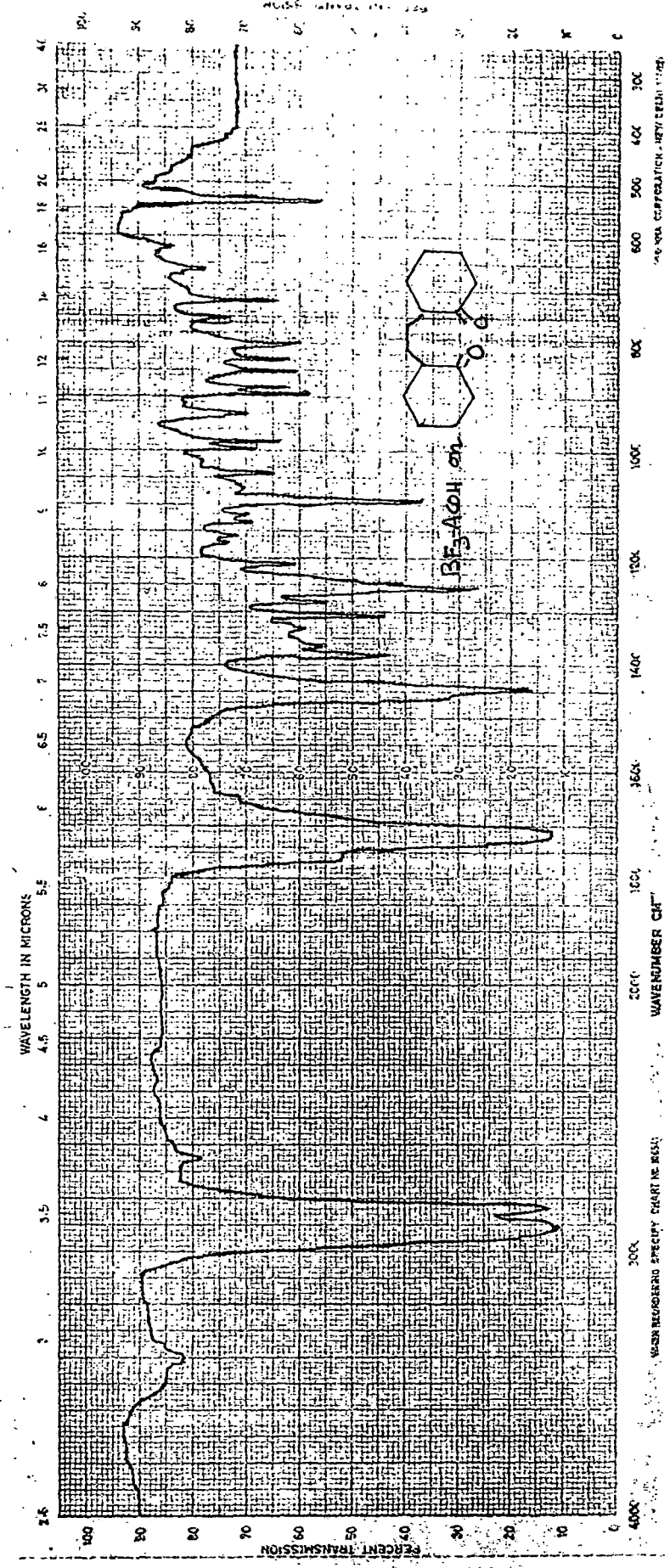

Spectrum 33

EM-360 60 MHz NMR SPECTROMETER

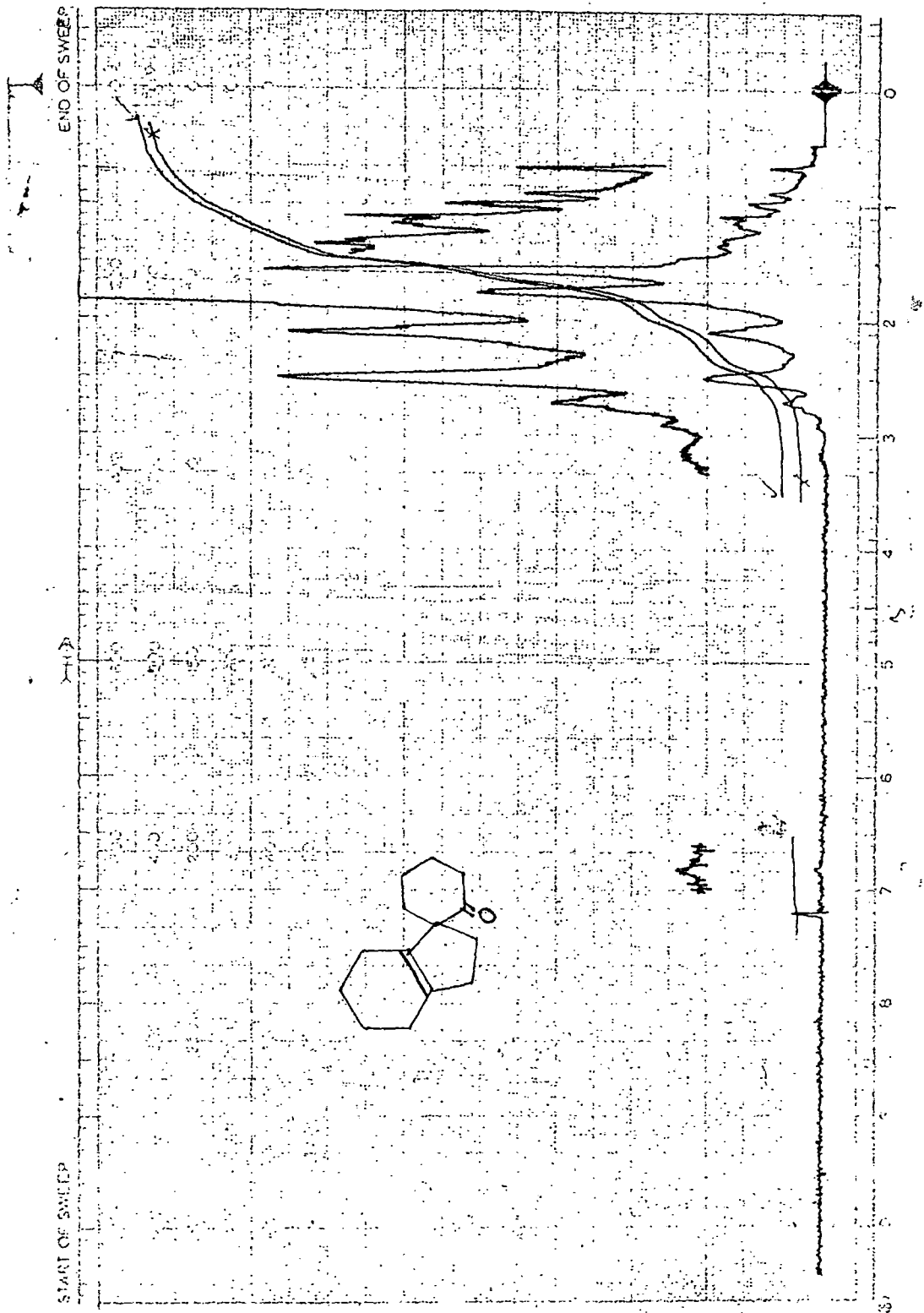

Spectrum 34

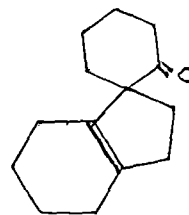
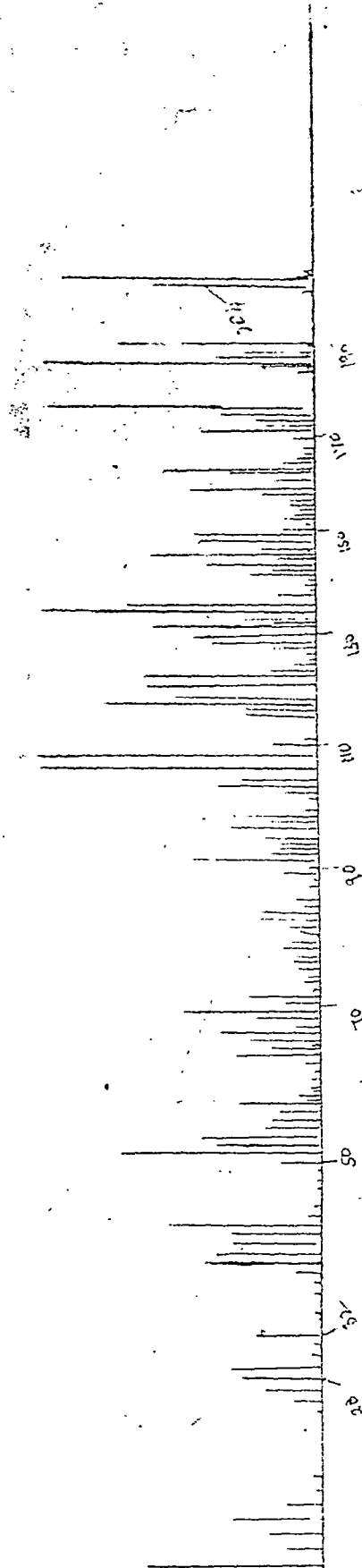

Spectrum 35

1. J.A. Marshall and P.C. Johnson J.Am.Chem. Soc., 89  
2750, (1967)
2. A.P. Krapcho Synthesis, 383 (1974); *ibid.*, 425, (1976)
3. M.Mousseron, R.Jacquier and H. Christol, Bull. Soc.  
chim. (France), 346, (1957).
4. P. Camps Ph.D thesis submitted to Barcelona University,  
(Spain) 1972; P.Camps and J.Pascual, Anal. Quim., 72  
1032 (1976).

\*\*\*\*\*

STUDIES IN ALICYCLIC SYSTEMS

PART III

Synthesis of Polyesters based on p-Hydroxybenzoic acid

In connection with some other work in our faculty, we were requested to prepare some compounds with thermotropic properties. The importance of these compounds in industry is too well known.

In this section we present in brief the synthesis of 1,2-bis(p-carboxyphenoxy)ethane (I) and 1,4-bis-(p-carboxy)-phenoxybutane<sup>1</sup> (II).

Though aryl esters of p-alkoxybenzoic acids are known to exhibit thermotropism, not much work seems to have been done on polyesters based on p-hydroxybenzoic acid with terminal mesogenic units and a central spacer. Only recently these compounds have been reported to exhibit thermotropic properties.<sup>2</sup>

The required bis-benzoic acids have been reported in as their ethyl or methyl esters mostly in patent literature.<sup>3</sup> These compounds have been prepared by condensing p-hydroxybenzoates with appropriate dihaloalkanes. In view of the

importance of these compounds, we investigated alternative routes to these compounds.

Condensation of phenol with 1,2-dibromoethane and 1,4-dibromobutane yielded 1,2-diphenoxyethane<sup>4</sup> (III) [m.p. 97°] and 1,4-diphenoxybutane<sup>5</sup> (IV) [m.p. 99°] respectively in appreciable yields.

It has been reported that aryl ethers are extremely sensitive to acylation and that acylation may occur in presence of less powerful catalysts than anhydrous aluminium chloride; even free carboxylic acids have been used as acylating agents.<sup>6</sup> Kosolapoff has reported that anisole can be acetylated by refluxing it with a mixture of glacial acetic acid and phosphoric acid in presence of calcium carbonate. In view of the extreme simplicity of this procedure and the reported very high yields, we attempted the acetylation of diphenoxyethane and diphenoxybutane by this procedure. A mixture of diphenoxyalkane, glacial acetic acid and phosphoric acid anhydride was refluxed in presence of calcium carbonate for two hours. The acyl compounds (V & VI) could be isolated in approximately 10% yields. \*\* Increasing the time of reflux

---

\*\* Diacetyldiphenoxybutane (VI) prepared by either method had correct molecular weight (m/e 326) but in the PMR only one COCH<sub>3</sub> could be accounted for. It appears that the mono-acetyl compound (VII) is formed in major quantity with the diacetyl compound in only a minor amount. As we had to

(contd on p 150)

or using varying proportions of the reactants had no marked effect on the overall yields.

Friedel Craft's acylation procedure using acetic anhydride and anhydrous chloride gave the diacetyl compounds in excellent yields. (see foot-note).

Oxidation of the diacetyl compounds with alkaline potassium permanganate<sup>7</sup> or sodium hypobromite gave 1,2-bis-(p-carboxy)-phenoxyethane (I) and 1,4-bis-(p-carboxy)-butane (II) as high melting compounds. They were identified as their ethyl esters by comparing with authentic samples prepared by condensing ethyl p-hydroxybenzoate with dibromoethane or dibromobutane.

The conversion of the diacetyl compounds to 1,2-bis-(p-aminophenoxy)ethane and 1,4-bis-(p-aminophenoxy)-butane is in progress. The investigation of the thermotropic properties of these compounds is being done by a separate group

---

depend on outstation research institutions for Mass and PMR spectra, we made what appeared to us to be a reasonable assumption that the diacetyl compound was formed (as in the case of diphenoxyethane) and proceeded with the next step. Interestingly, the derived diacid was found to be the desired dicarboxylic acid (q.v.)

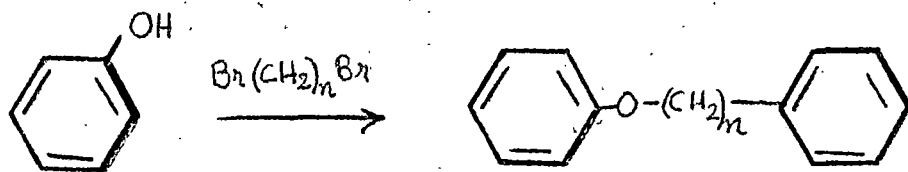

III (n=2)

IV (n=4)

$(\text{CH}_3\text{CO})_2\text{O} / \text{AlCl}_3$

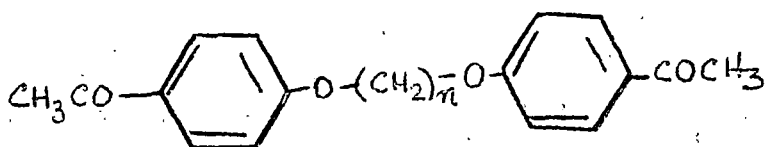

V (n=2)

VI (n=4)

[O]

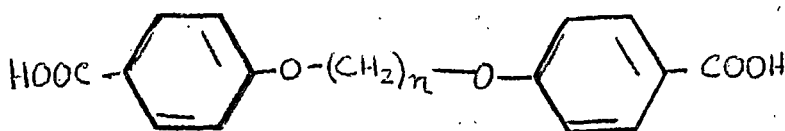

I (n=2)

II (n=4)

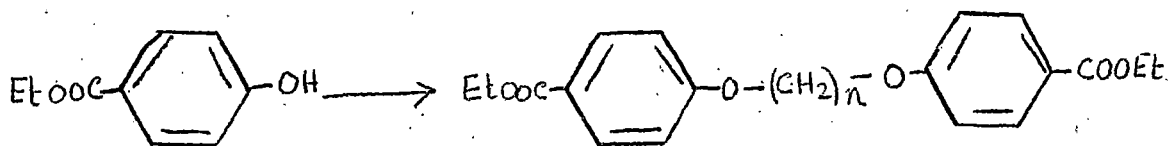

of workers in the Department of Physics of our University.

STUDIES IN ALICYCLIC SYSTEMS

PART III

EXPERIMENTAL SECTION

### Diphenoxyethane (III) and Diphenoxybutane (IV)

A mixture of phenol (0.2 mole), dibromoalkane (0.1 mole) 10% aqueous sodium hydroxide solution and sufficient rectified spirit to make the solution homogeneous was refluxed for a period of five hours. The reaction mixture was cooled and diluted with water to afford the diphenoxyalkanes.

Diphenoxyethane (III) m.p.  $97^{\circ}$  (Lit<sup>4</sup>  $97^{\circ}$ )

IR (nujol) ( $\text{cm}^{-1}$ ) (Spectrum 36)

1600, 1490, 1450, 1380, 1290, 1250, 1170, 1080, 1050,  
920, 880, 790

Diphenoxybutane (IV) m.p.  $99^{\circ}$  (Lit<sup>5</sup>  $98^{\circ}$ )

IR (nujol, in  $\text{cm}^{-1}$ ) (Spectrum 37)

1600, 1490, 1460, 1450, 1380, 1310, 1290, 1250, 1200, 1170,  
1080, 1050, 970, 870, 850, 750, 680, 600, 510

Acetylation of the phenoxyalkanes: Formation of the acetyl compounds (V) and (VI)

Kononoff's procedure <sup>6</sup>

A mixture of diphenoxyalkane (0.01 mole), phosphoric anhydride (0.02 mole) and calcium carbonate (1.0 g) in anhydrous benzene (100 ml) was refluxed with glacial acetic

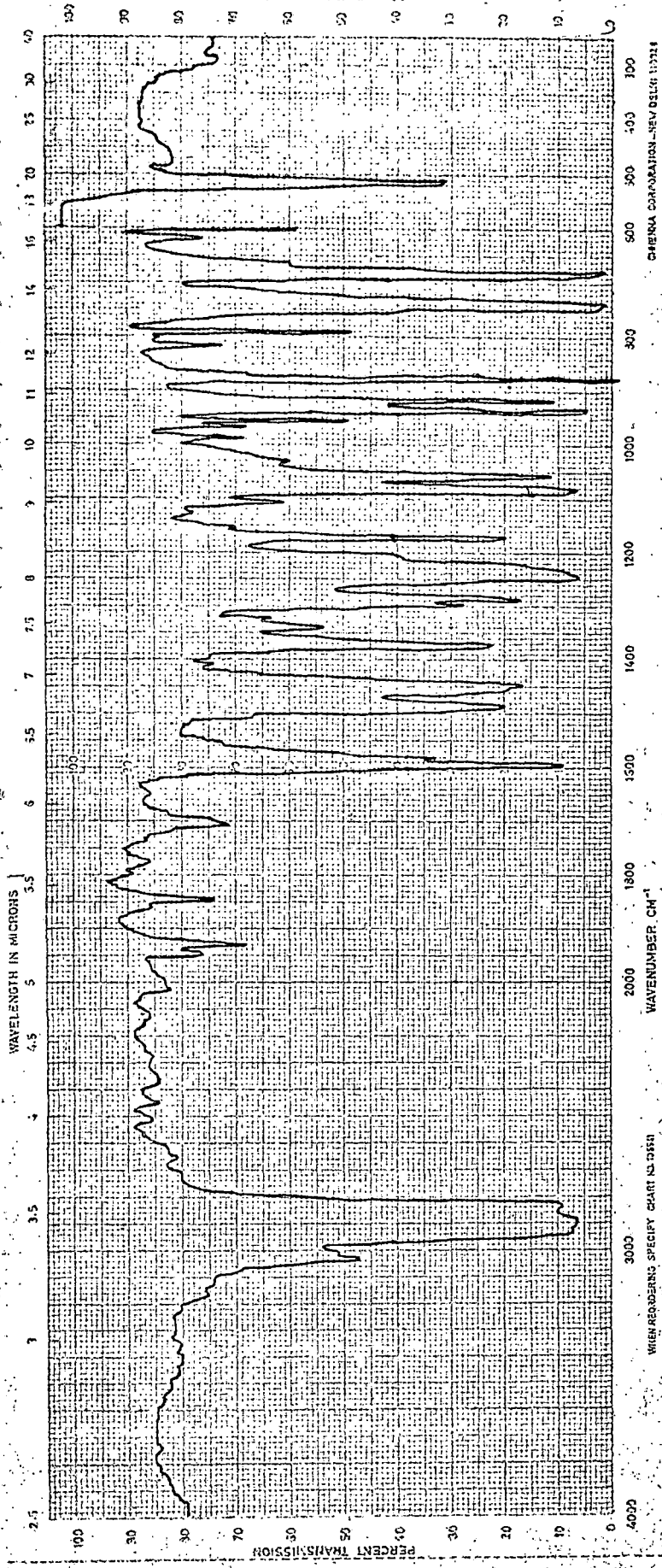

SPECTRUM # 36

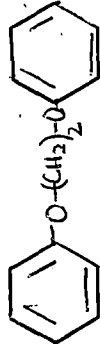

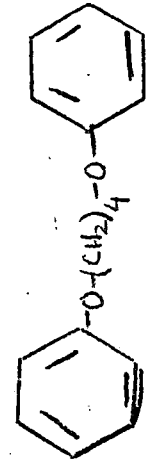
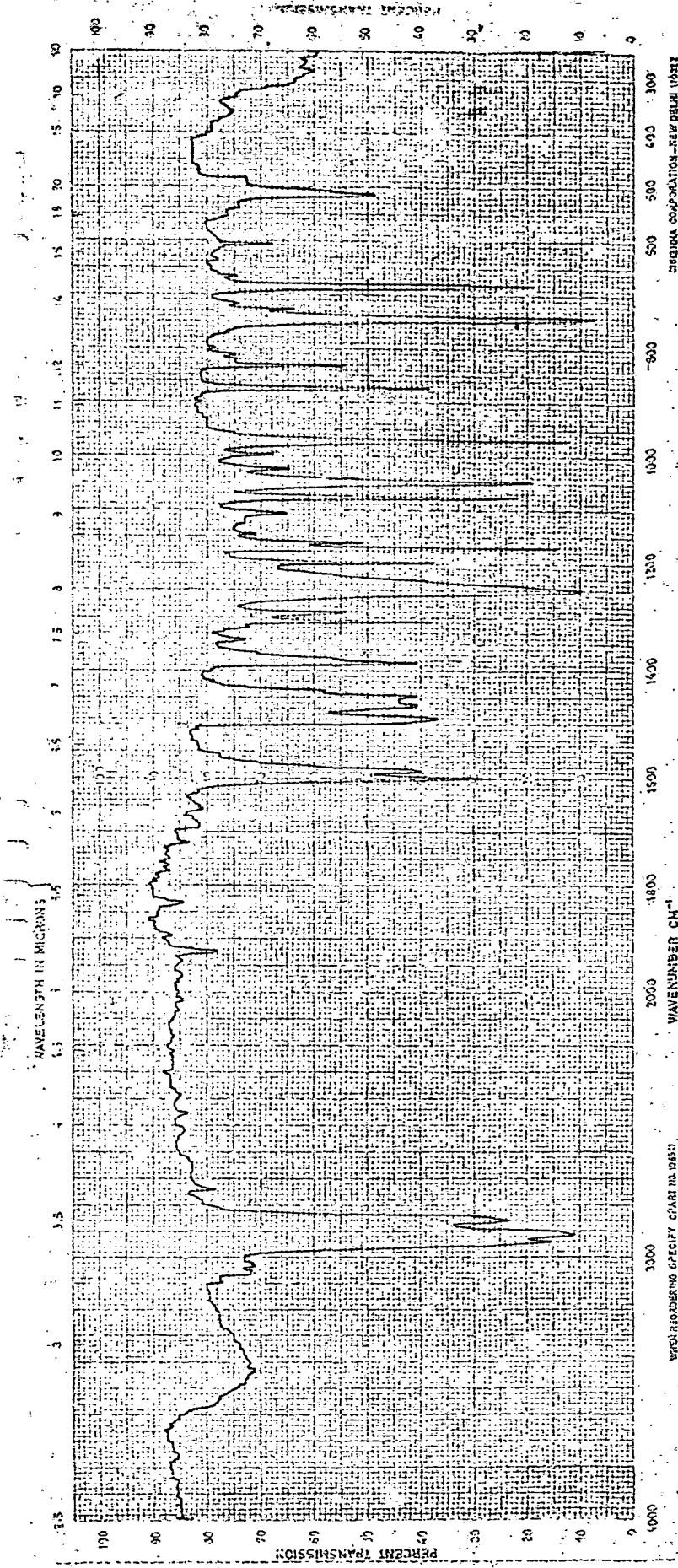

SPECTRUM 37

(0.02 mole) with continuous stirring for two hours. Usual working up afforded the diacetyl compounds (V) and (VI) in approximately 10 % yields.

Diacetyldiphenoxyethane (V) m.p. 159°

IR (nujol, in  $\text{cm}^{-1}$ ) (Spectrum 38)

1680, 1600, 1365, 1310, 1260, 1180, 1120, 1080, 960, 840  
820.

PMR (ppm) (Spectrum 39)

2.48 (6H, s), 4.44 (4H, s), 6.8 - 8.0 (8H, m)

Mass (Spectrum 40) (m/e)

298, 283, 256, 214, 163, 121, 120

Diacetyldiphenoxybutane (VI) m.p. 135°

IR (nujol, in  $\text{cm}^{-1}$ ) (Spectrum 41)

1680, 1600, 1365, 1330, 1290, 1260, 1180, 990, 870

PMR (ppm) (Spectrum 42)

2.45 (3H, s), 3.8 - 4.2 (3H, multiplet), 7.0-8.0 (8H, m)

Mass (m/e) (Spectrum 43)

326, 192, 149, 121, 119, 107

Friedel Craft's acylation procedure:

To a mixture of diphenoxyalkane (0.05 mole) and acetic

\*\*\*

Please see the foot note on p- 149.

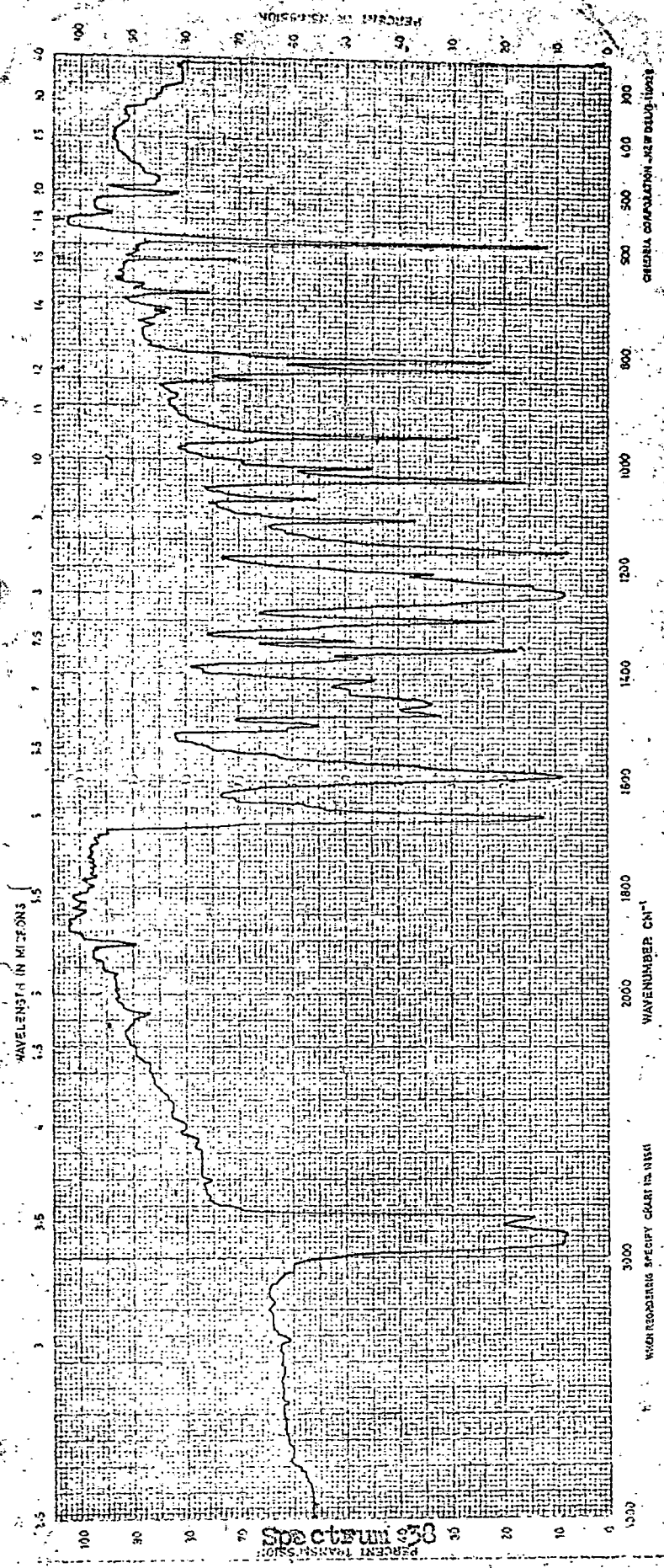

Spectrum 53

GENERAL COMPUTATION NEW DELHI-110028

WATER RESISTANT SPECIFIC GRAVITY 1.1561

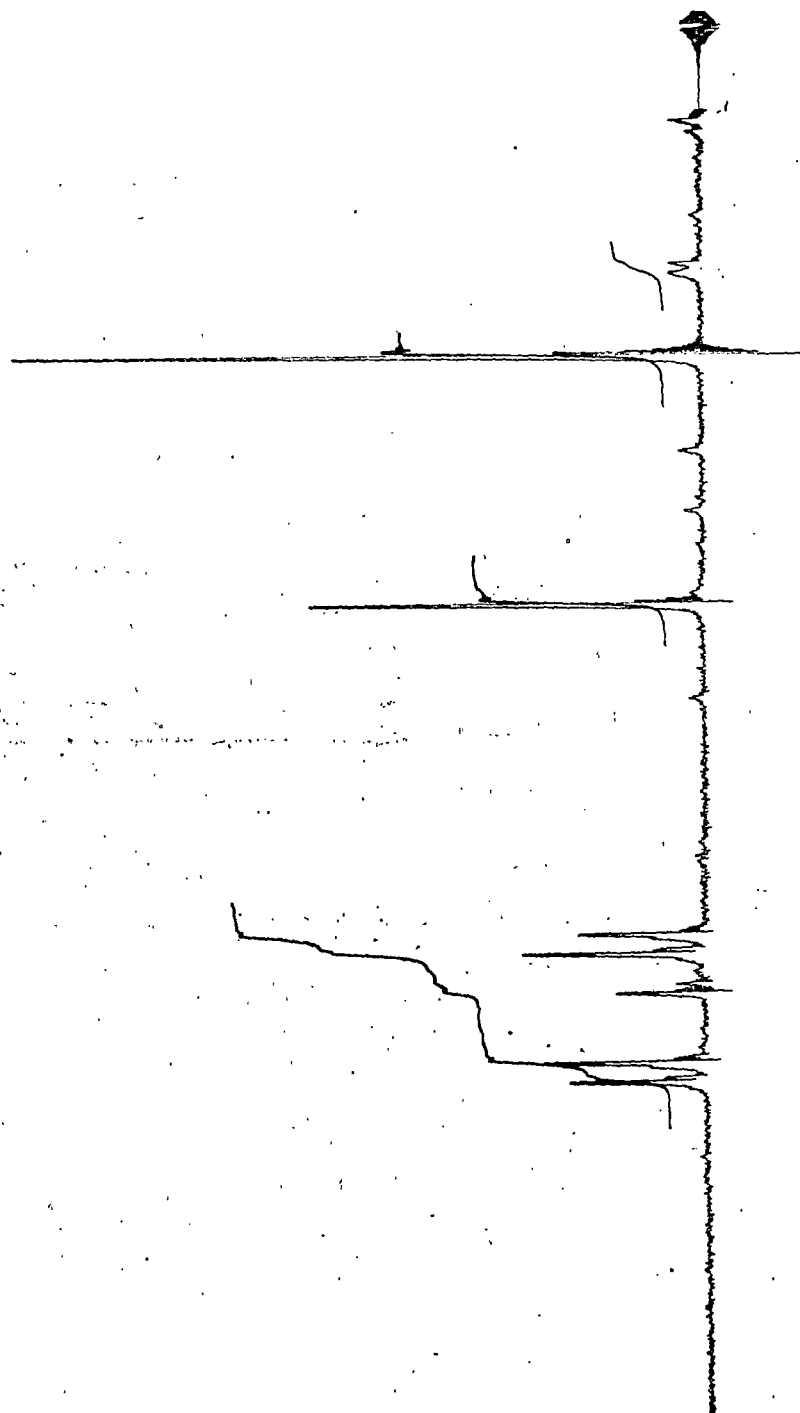

Spectrum 39

MASS SPECTRUM : (6 TO 7)  
SAMPLE : MM-1, DR. A. K. GHOSH, N. W. UNIVERSITY.  
NOTE : 2ND, AUG., 1982  
BASE PEAK : M/E 77.0 INT. 563.0

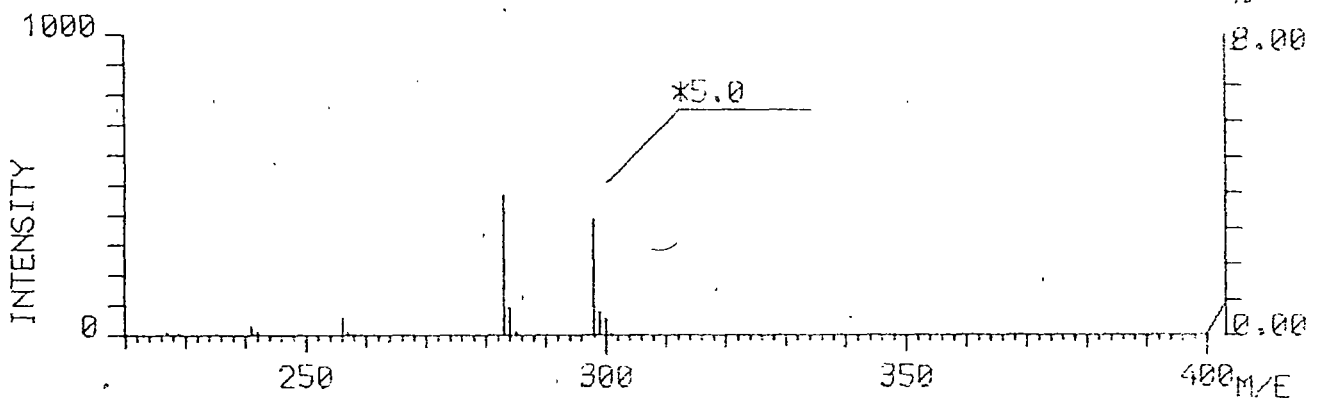
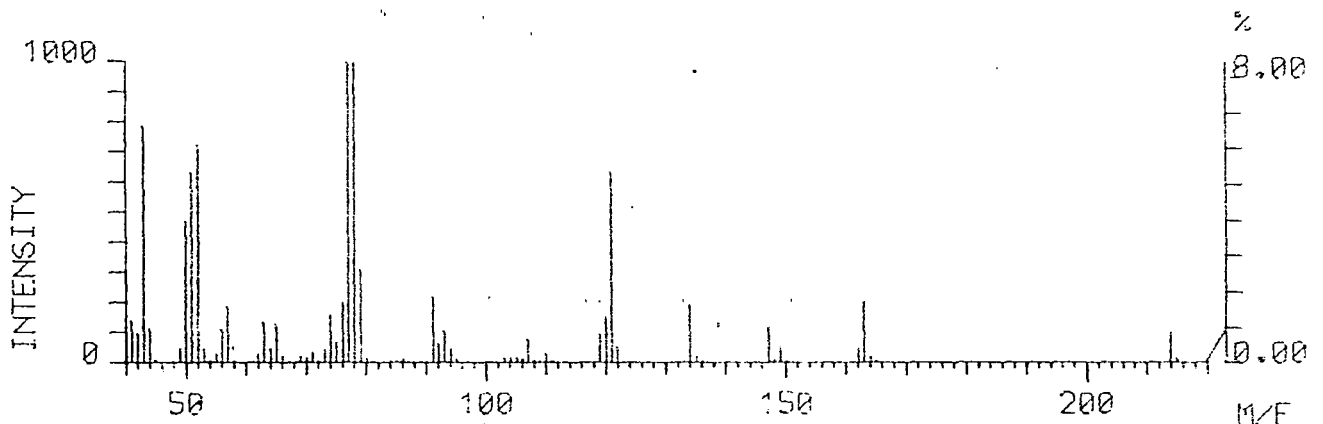

Spectrum 40

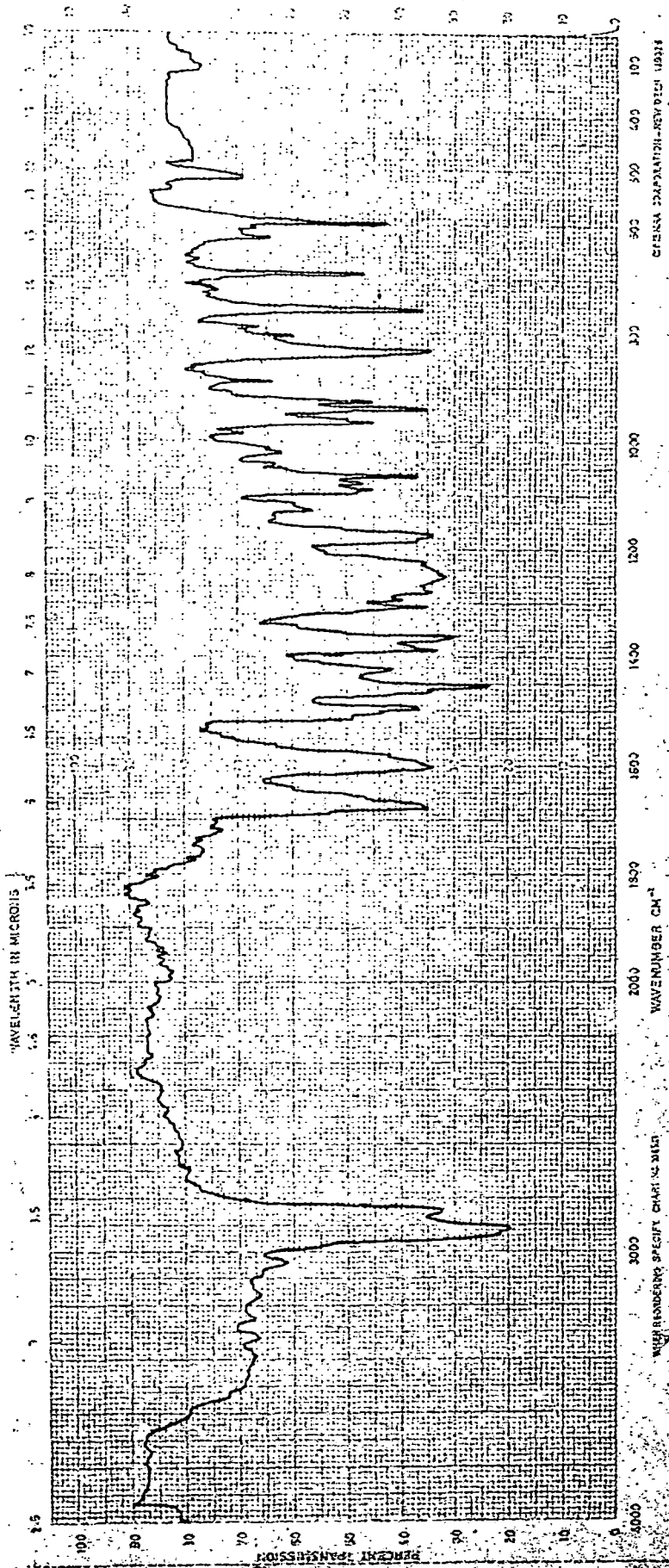

SPECTRUM 41

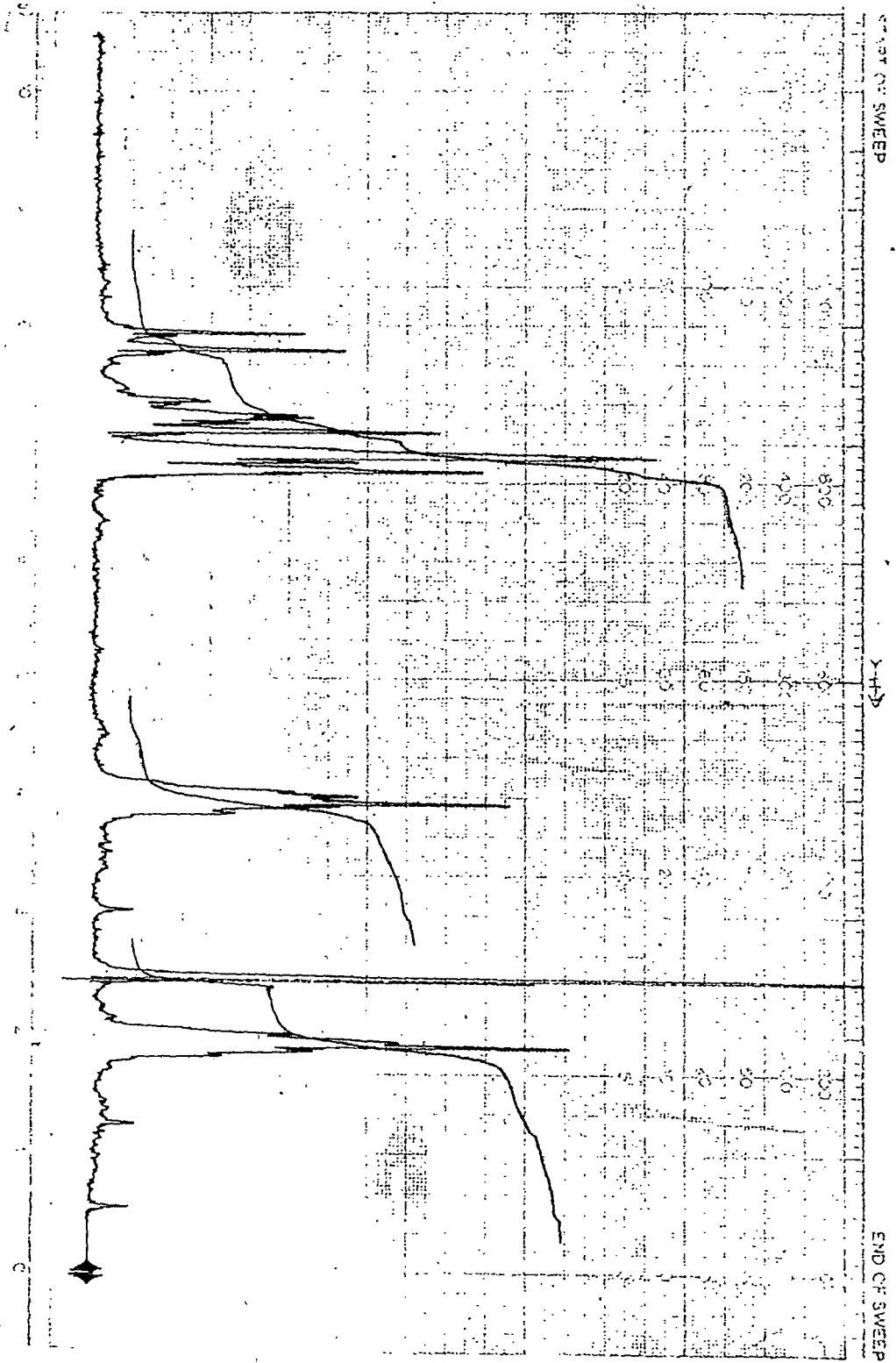

MINI-NI SPECTROMETER

(Spectrum 42)

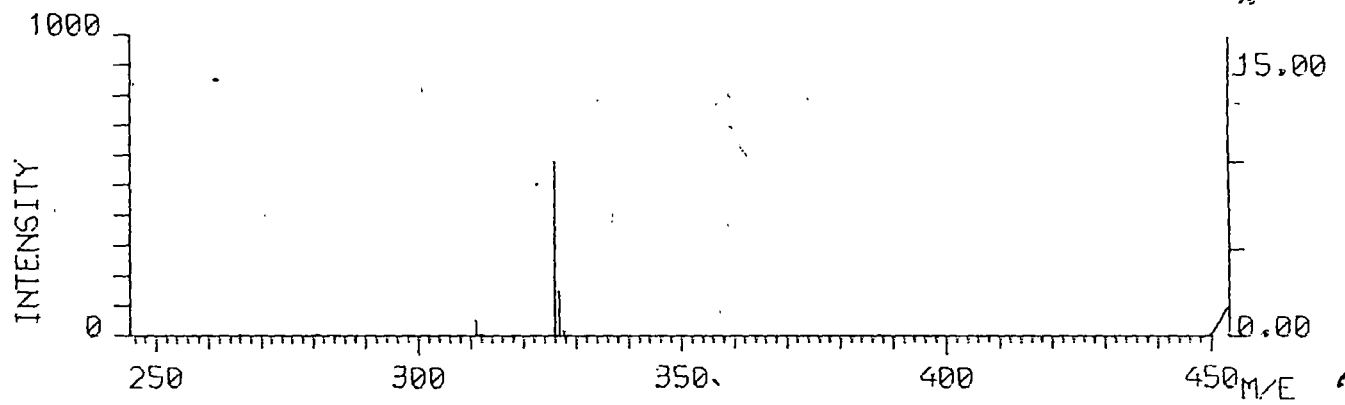
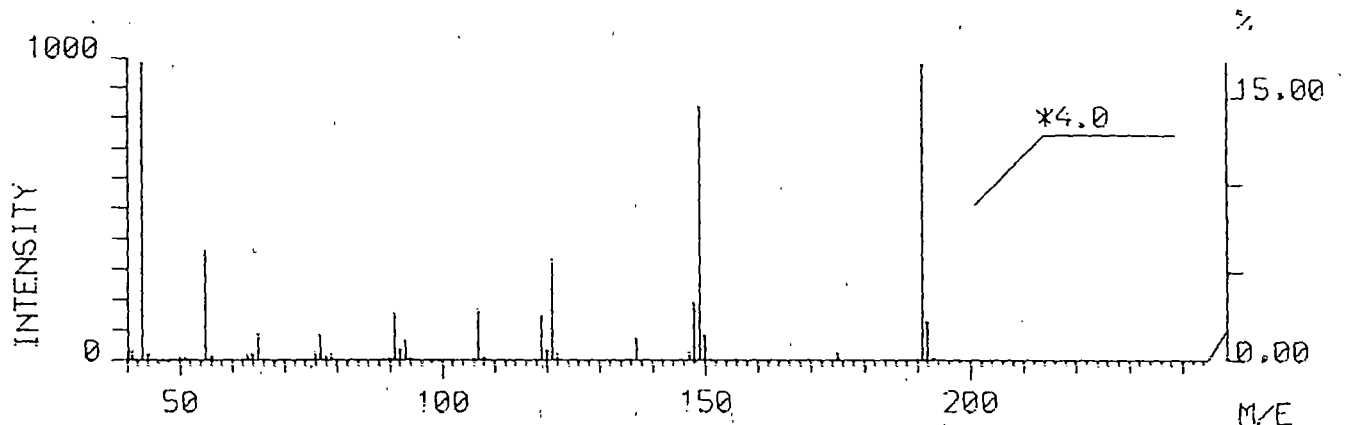

Spectrum 43

anhydride (0.1 mole) in carbon disulphide (100 ml) was added with cooling and stirring anhydrous aluminium chloride (0.15 mole) in small lots. After the addition, the reaction mixture was stirred for a period of three hours and left overnight at room temperature. Usual working up gave the acetyl compounds in nearly 80% yields. They were found to be identical with the ones obtained from the previous method.

Dicarboxydiphenoxy alkanes (I) and (II)

Oxidation of the acetyl compounds with alkaline potassium permanganate

The acetyl compound (500 mg) was refluxed with 10% potassium permanganate in 10% aqueous potassium hydroxide solution for two hours. Acidification of the reaction mixture gave the crude diphenoxy acids which were redissolved in sodium carbonate solution and filtered to remove suspended impurities. Acidification gave the acids (I) and (II) as very high melting solids.

1,2-Bis-(p-carboxyphenoxy)-ethane m.p. 250

Mass spectrum 44

m/e 302, 298, 283, 211, 210

PMR Spectrum 45

1,2-Bis(p-carboxyphenoxy)-butane m.p. 250

Mass Spectrum 46

m/e 330, 238, 221

MASS SPECTRUM : (9 TO 10)  
SAMPLE: MM-3, DR. A. K. KHOSH, N. W. UNIVERSITY  
NOTE : 2ND AUG. 82  
BASE PEAK : M/E 45.0 INT. 315.0

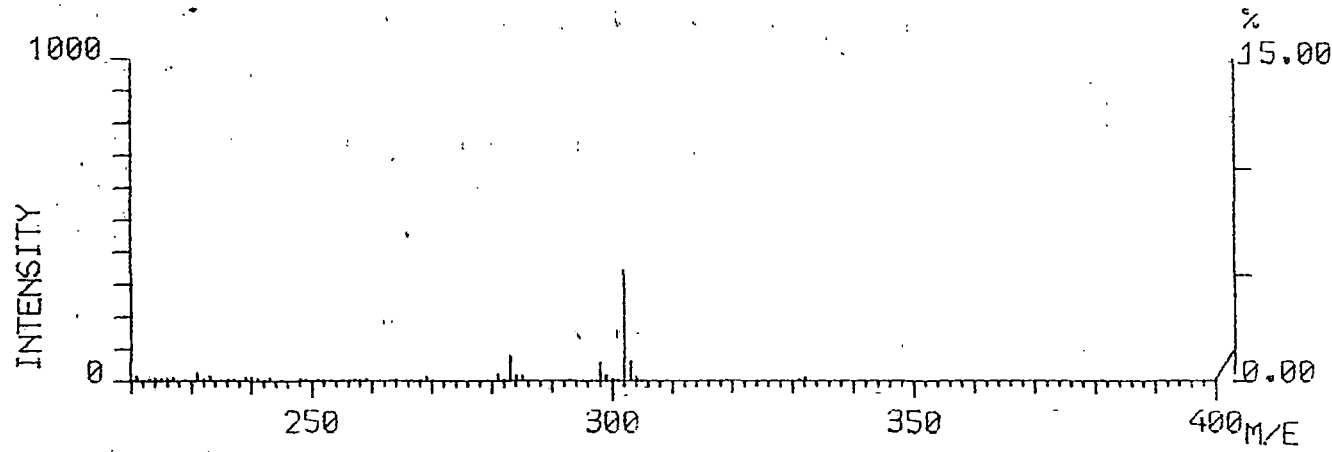
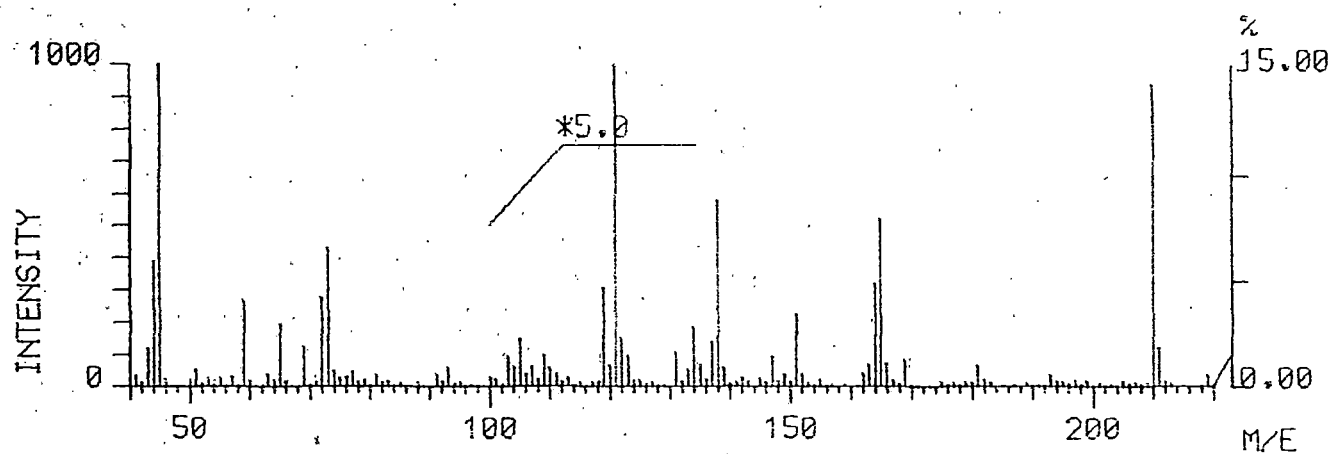

Spectrum 44

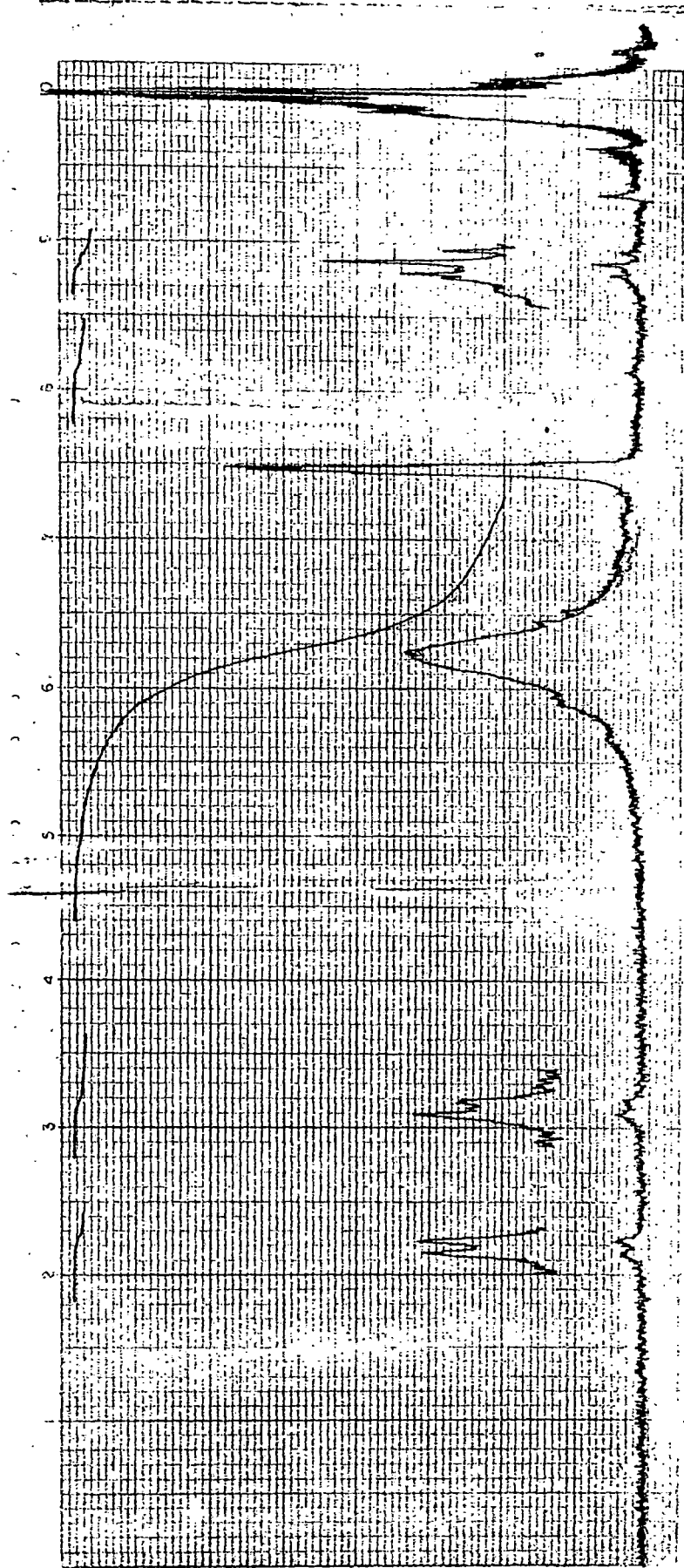

SPECTRUM 45

MASS SPECTRUM : (3 TO 4)  
SAMPLE: MM-4, DR. A.K. GHOSH, N.W. UNIVERSITY  
NOTE : 2ND AUG. 82  
BASE PEAK : M/E 121.0 INT. 633.8

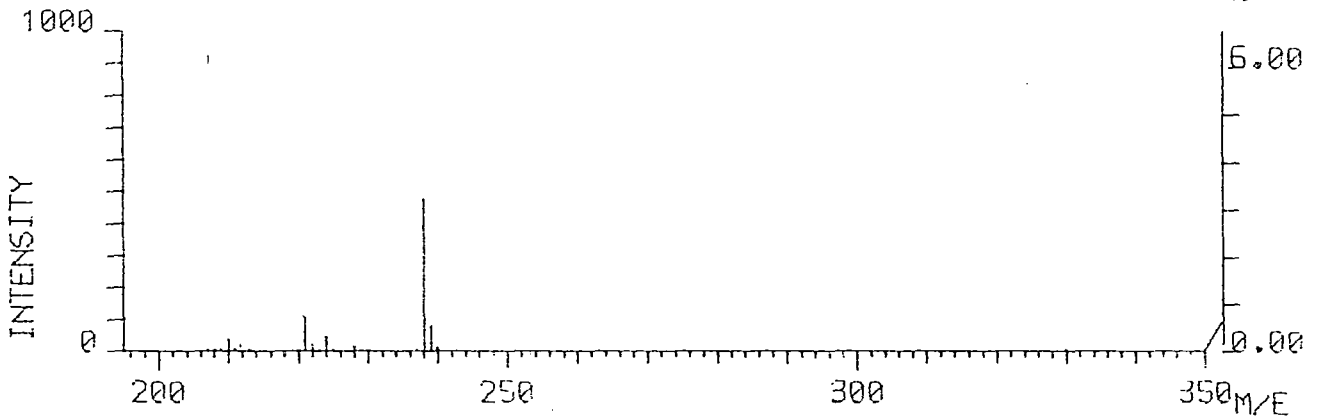
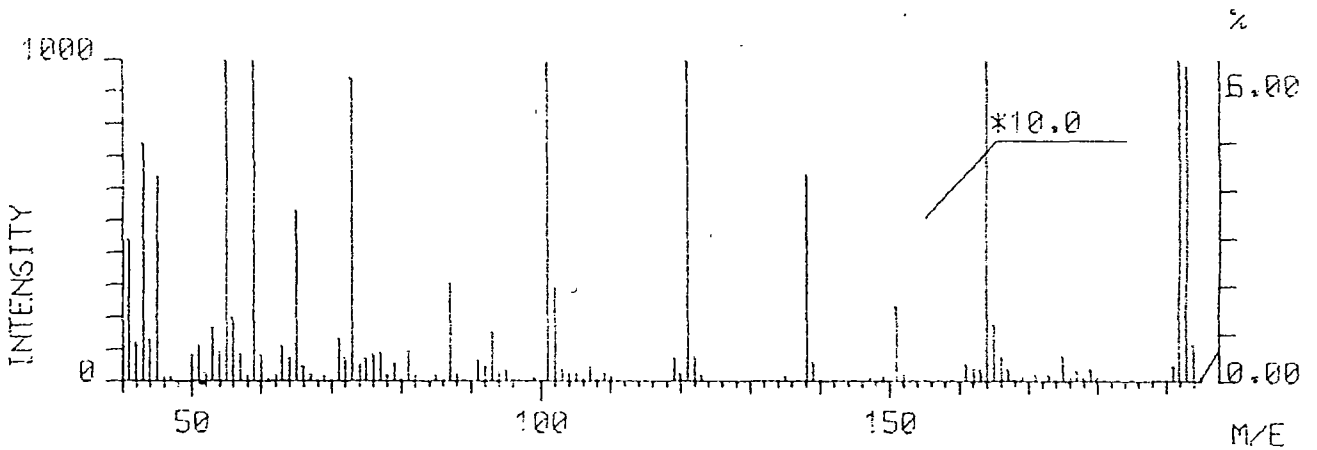

SPECTRUM 46

Oxidation with sodium hypobromite

To a cooled solution of sodium hydroxide (20 g) in water (175 ml) was added bromine (9.5 ml) with stirring. Into this was introduced a solution of the diacetyl compound (0.05 mole) in dioxane with stirring and cooling over a period of one hour. The stirring was continued for a further period of two hours. Usual working up gave the dicarboxylic acids in approximately 30% yields.

The acids were converted into their ethyl esters by standard procedure.

1,2-Bis-(p-ethoxycarbonylphenoxy)-ethane m.p. 70°

1,4-Bis-(p-ethoxycarbonylphenoxy)-butane m.p. 85°

The esters showed no depression in melting point on admixture with authentic samples prepared by condensing ethyl p-hydroxybenzoate (0.1 mole) with dibromoalkane (0.08 mole) in presence of sodium carbonate (0.5 g) in methanol (50 ml) containing a little diglyme.

### \*\*\* ###

REFERENCES

1. G.S.S. Murthi & Mrs M. Murthi, Presented at the 70th session of the Indian Science Congress, Tirupati 1983 Proc. 70th Indian Sci. Cong. Section IV (1983) 75
2. Jung-Il, Young-Seogchung and Joo-Sam Kang, Mol. Cryst. Liq. Cryst. Letters, 82, 261, (1983)
3. For e.g. Inai Norio, Kato, Toshio, Iwasaka, Hirofumi, Fukusaka, Yohei Chem. Abs 84, 135319 (1976); 84, 135320 (1976), Senoo, Saburo, Kato, Toshio, Kurihara, Masatazu, Ito, Mirataka, Sato, Kenichiro *ibid.*, 80, 26925 (1974)
4. H.B. Menbest, J.A.W. Reid, J.Chem Soc., 5239 (1961)
5. E.Welthius and D.Bouma Tetrahedron Letters 467, (1970)
6. G.M. Kosolapoff J.Am. Chem. Soc., 69, 1651 (1947)
7. A.I. Vogel, "A Text Book of Practical Organic Chemistry," E.L.B.S. & Longman (London) 1978 p 1111
8. *Idem.* *ibid.*, 476

STUDIES IN ALICYCLIC SYSTEMS

ABSTRACTS OF PAPERS PRESENTED AT DIFFERENT SCIENCE CONGRESSES

BY THE AUTHOR

sulphonamide bases when the corresponding 4,6-dimethyl-5-(arylo/N-substituted *p*-sulphamyl)benzocopyrimidino-2-thiols were obtained. The structures were confirmed by elemental analysis, IR and NMR spectral data. These showed considerable in vitro activity against *S. aureus*, *E. coli* and *P. pyocyanea*.

Org. 4. Synthesis of 2-Alkyl-3-Substituted Indoles as Potential Biodynamic Agents.

ANIL K. SEN GUPTA, (Miss) NEERA SRIVASTAVA  
and ANURAG AJEET GUPTA, Lucknow

Ethyl-2-alkylindole-acetates were treated with hydrazine hydrate to furnish 2-alkylindolacetyl hydrazides. These on condensation with carbonyl compounds furnish 2-alkyl-3N(N-1-methyl-1-phenyl)imino]-acetamidoindoles. On the other hand the cyclisation of 2-alkyl indolacetyl-hydrazides with  $CS_2/KOH$  gave 3-(2-mercapto-5-oxadiazolyl)methyl-2-indole. The "Mannich Reaction" of 3-(2-mercapto-5-oxadiazolyl)methyl-2-indole with different aromatic amines furnished 3-[2-Thio-3(2-aryl)amino methyl-5-oxadiazolyl]-methyl-2-alkyl indoles. The compounds have been found to be non-toxic psychotropic agents. Some of them are antibacterial agents against *Staphylococcus aureus* and *Bacillus subtilis*.

✓ Org. 5. A New Synthesis of Phenothiazines:

G. S. S. MURTHI, A. MAJUMDER and (Mrs.) M. MURTHI, Darjeeling

Phenothiazine and its 3-methyl, 3-chloro and 3-nitro derivatives have been prepared by a new method which consists in the condensation of aniline, *p*-toluidine, *p*-chloro aniline and *p*-nitro aniline with cyclohexanone followed by heating the resultant Schiff base with sulphur at 250-260° for six to eight hours. The compounds have been identified by comparison with authentic samples.

171. Synthetic Approach Towards 1-Oxo-Tetrahydro- $\beta$ -Carboline.

(Mrs.) Asima Chatterjee, Uttam Kumar Pandit and  
Somnath Ghosh, CALCUTTA

The ethanolic extract of the root bark of *Alstonia venenata* R. Br. (Apocyanaceae) has afforded a new base-5-methoxy-1-oxo-tetrahydro- $\beta$ -carboline which is presumed to act as a biogenetic precursor for the yohimbinoïd alkaloids. In continuation of our studies on the synthesis of such systems a simple route to the synthesis of the desmethoxy compound has been developed. The latter can serve as an important model experiment for the synthesis of alkaloids having this heterocyclic unit.

Tryptamine (I) was condensed with ethylchloroformate to afford N-[2-(2-carbethoxy-3-indolyl)-ethyl]-urethan (II) in 71% yield along with a minor amount of N-[2-(3-indolyl)-ethyl]-urethan (III). The diester (II) was selectively hydrolysed to yield the monoester (III). The latter was cyclised to 1-oxo-tetrahydro- $\beta$ -carboline (IV) by Bischler Napieralski reaction. This method has been extended for the synthesis of a few other 1-oxo derivatives.

172. Synthesis of Some Substituted Diazo Phenylthiazoles and Evaluation of their Antifungal and Antibacterial Properties.

Suryamani Behera, BHUBANESWAR

Various Phenols were used for the synthesis of some substituted diazo phenylthiazoles through the preparation of amino phenyl thiazole and subsequent diazotisation. Their fungicidal and bactericidal properties were studied and found to be quite encouraging.

173. Synthesis of 1,2 Bis (p-carboxy)-phenoxy Ethane and 1,4 Bis-(p-carboxy) Phenoxy Butane.

G. S. S. Murthi and (Mrs) M. Murthi, DARJEELING

The title compounds whose aryl esters are likely to find use as liquid crystals have been prepared from 1,2-diphenoxy ethane and 1,4-diphenoxy butane. Friedel Crafts acetylation of the phenoxy alkanes

with acetic anhydride using anhydrous aluminium chloride as catalyst gave 1,2 bis-(p-acetyl)-phenoxy ethane and 1,4 bis-(p-acetyl)-phenoxy butane in 80% yields. Oxidation of the diacetyl compounds with either alkaline potassium permanganate or sodium hypobromite yielded the title compounds. The acids have been identified as their ethyl esters by comparison with authentic samples prepared by condensing ethyl p-hydroxy benzoate with 1,2-dibromo ethane and 1,4-dibromo butane.

174. Biologically Active Imidazoles.

Late K. Kishore, LUCKNOW

and

R. C. Gupta, MEDZIPHEMA (Nagaland)

Some new 1-Phenyl (4'-aryl thio semi carbazide) imidazoles have been synthesised to study their pharmacological properties. These compounds have been tested for amoebicidal and fungicidal activity.

175. Synthesis and Carcinogenic Activity of some Substituted Dihydro Benzo acridines and Corresponding B-Homo Analogues.

Jayanta K. Roy, KHARAGPUR

Some substituted cyclohexanones, indanones, tetralones and suberones were converted to their chloroaldehydes by Vielsmayer-Reaction ( $\text{POCl}_3$ -DMF). The resultant products were converted to substituted benzoacridines and related compounds through anil derivatives followed by cyclisation at high temperature. The synthesised acridine derivatives were tested for carcinogenic activity by fluorescence technique and a few were found to be good furochrome.

176. Synthesis for Some 2-Benzoylcoumaran-3-Ones.

A. K. D. Majumdar, K. Kumar, G. C. Saha, T. K. Sinha

and K. D. Banerji, BHAGALPUR

Synthesis of several 2-benzoylcoumaran-3-ones, most of which contain halogen atoms in both the benzenoid rings, have been described following three different routes. All the coumaranones obtained by the three routes have been found to be identical in all respects.

172. **Studies in Allicyclic Systems-Synthesis and Reactions of 1,2-Bis-(2'-Oxocyclohexyl)-Ethane**

G. S. S. Murthi and M. Murthi, Darjeeling

Cyclohexanone has been condensed with 1,2-dibromoethane to yield the hitherto unknown 1,2-bis (2'-oxocyclohexyl)-ethane. The structure has been assigned on the basis of its mass spectrum. The title compound has been converted to a dihydroxy perhydrophenanthrene.

173 **Isolation and Synthesis of New Anthraquinone Glycoside from the Pods of *Cassia occidentalis*.**

J. Singh, Allahabad

A new anthraquinone glycoside,  $C_{27}H_{26}O_{16}$  was isolated from the ethanolic extract of the pods of *Cassia occidentalis* pods. The structure of the glycoside has established on the basis of colour reactions, spectral data and chemical reactions. For definite structure proof, the glycoside was synthesised by usual methods.

Anthraquinone 1,3,5,8-tetrahydroxy-2-methyl anthraquinone has been synthesised by condensing 3,6 dihydroxy phthalic anhydride with 2,6-dihydroxy toluene in the presence of  $AlCl_3/NaBr$  followed by bromination and then cyclisation with oleum in presence of boric anhydride.

Glycosidation of aglycone with  $\alpha$ -bromorutinose is carried out in presence of silver carbonate and pyridine. The resulting product obtained was deacetylated with NaOMe in methanol to yield glycoside identical in every respect with natural product.

174 **Synthesis of N<sup>1</sup>-Isonicotinoyl-3-Methyl-4 (Substituted Arylidene) 2-Pyrazolin-5-ones and evaluation of their Antifungal Activity.**

C. P. Singh and Archana Singh, Najibabad

Nine N<sup>1</sup>-isonicotinoyl-3-methyl-4 (substituted arylidene)-2-pyrazolin-5-ones have been synthesised with a view to study their antifungal activity. All

226. Studies in alicyclic systems actions of  $\text{BF}_3\text{-AcOH}$  on 1,2-DI-(2-Oxocyclohexyl)-Ethane.

G. S. S. Murthi, (Mrs) M. Murthi and A. Majumder  
Department of Chemistry  
North Bengal University  
Darjeeling-734 430

1,2-di-(2-oxocyclohexyl) - ethane was cyclized by boron-trifluoride-acetic acid complex to  $\Delta^{1-6}$  bicyclo [4 : 3 : 0] nonan-7-spirocyclohexan-2-one. The structure was assigned on the basis of NMR, Mass and IR Spectra. Cyclization by NaOMe to 6-hydroxy bicyclo-[4 : 3 : 0] nonan-7-Spirocyclohexane-2 one was attempted without success.

m-cresol in a 5 step sequence. The structure has been confirmed by Mass Spectrum. Attempted Reformatsky reaction with the compound failed.

228. **Alicyclic Compounds Action of Base on 4, 10  $\alpha$ -Epoxy-9- $\beta$ -Tosyloxymethyl 3-Oxo-Decalin.**

G. S. S. Murthi and (Mrs) M. Murthi

Department of Chemistry  
University of North Bengal  
Darjeeling 734430

4, 10  $\alpha$ -Epoxy-9- $\beta$ -tosyloxymethyl-3-oxo-decalin has been prepared in a seven step sequence from ethyl cyclohexanone-2-carboxylate. Treatment of the epoxy keto tosylate with sodiumhydroxide at 0° for three hours gave a neutral compound as a sweet smelling oil. The mass. spectrum indicated the formation of the compound by the elimination of the tosyloxy group. On the basis of ir, Uv & PMR spectra cyclodecadiene structure has been proposed.

229. **Synthesis of Condensed Pyrimidines : Reaction of Heterocyclic Amines with Ethoxymethylene Malonate**

A. Nayak

Department of Chemistry, Sambalpur University  
Jyoti Vihar, Sambalpur-768019, Orissa

The synthesis of a few new 3-aryl-6-carboethoxythiazolo [3, 2-a] and 2-aryl-6-carboethoxy-1, 3, 4-oxa/thiadiazolo [3,2-a] pyrimidine-5 (H)-ones have been reported by the reactions of aminothiazoles and oxa/thiadiazoles respectively with ethoxymethylenes diethylmalonate. The structures of these compounds have been established by the characterisation of their intermediates as well as the spectral studies.

hydroxycholest-5-en-7-one oxime (iv). The structures of these compounds were established on the basis of Elemental and spectral analysis.

**226. Studies in alicyclic systems actions of  $\text{BF}_3\text{-AcOH}$  on 1,2-DI-(2-Oxocyclohexyl)-Ethane.**

G. S. S. Murthi, (Mrs) M. Murthi and A. Majumder  
Department of Chemistry  
North Bengal University  
Darjeeling-734 430

1,2-di-(2-oxocyclohexyl) - ethane was cyclized by boron-trifluoride-acetic acid complex to  $\Delta^{1-6}$  bicyclo [4 : 3 : 0] nonan-7-spirocyclohexan-2-one. The structure was assigned on the basis of NMR, Mass and IR Spectra. Cyclization by NaOMe to 6-hydroxy bicyclo-[4 : 3 : 0] nonan-7-Spirocyclohexane-2 one was attempted without success.

**227. "A novel synthesis of w-Bromo-o-aryloxyacetophenones."**

V. G. Thakare & K. N. Wadodkar  
Department of Chemistry  
Vidarbha Mahavidyalaya  
Amravati-444 604

A novel and more convenient method for the synthesis of w-bromo-o-aryloxyacetophenones involves the bromination with dioxane- $\text{Br}_2$  complex in presence of DMF. Thus eight variously substituted o-aryloxyacetophenones (Ia-h) on bromination with  $\text{Br}_2$  in dioxane in presence of DMF give

RECEIVED  
JAN 10 1968  
LIBRARY  
INDIAN INSTITUTE OF TECHNOLOGY  
KAROL BAGH, NEW DELHI